

Quotation

To

Company :	Siemens AG	Name :	N. HOST
City / Country :	Duisburg / Germany	Dept :	Sales Dept.
Name :	Stoverink Simon	Tel :	+33 (0)3 69 20 51 50
Dept :		Fax :	+33 (0)3 88 67 60 75
Tel :		E-mail :	nhost@flender-graff.com
Fax :		Page(s) :	19
E-mail :		Copy :	
		Date :	16.03.2015

Y/ref : Khursaniyah Al Fadhili - D43-K-1801 -
O/ref : D41104 quotation number 3

In response to your inquiry referenced above, we are pleased to confirm our quotation as follows :

ITEM A 1 : Flender Graffenstaden (FG) High Speed increaser, model **TX50/4C**

- *Rating conditions :* Rated power at **6800 kW**
Driven by a electric motor at **1800.0 rpm** (specified : 1800.0 rpm)
Driving a centrifugal compressor at **7309.1 rpm** (specified : 7285.0 rpm)
Service factor **1.45** according to **API613/03** (required : > 1.4)
- *Technical description :* Double helical
Manufacturing according to API standard
Flange on LS shaft end
Flange on HS shaft end
Estimated Weight : 4000 kg
- *Bearings description :* 2 cylindrical bearings on LS shaft
2 offset bearings on HS shaft
1 double acting tilting pad thrust bearing on low speed shaft non driven end
- *Mechanical running test :* Full speed, no load test during 4 hours according to the API 613 5th Edition standard.
- *Lubrication conditions :* 164 l/min of Oil ISO VG 46 at 60°C and 2.5 bar at inlet (calculated values only)
- *Miscellaneous:* Efficiency at full load : 99.03 %
Power losses at full load : 66 kW (calculated value only)
Anticipated Sound Pressure Level: 82.0 ± 2dB(A) at 1 meter

Base price : 117 900 EUR each gear box
Delivery time : 36 weeks after the FG acknowledgement of the order
Quantity : 8 gearboxes

FLENDER GRAFFENSTADEN

FLENDER-GRAFFENSTADEN S.A., FRANCE
BP 84, F-67402 ILLKIRCH-CEDEX
1, rue du Vieux Moulin
F-67400 ILLKIRCH-GRAFFENSTADEN

Comments :

- Coupling data taken into account on HS Shaft:
 - o Weight: 26.6 kg
 - o Center of gravity position from shaft end: 30.9 mm
 - o Inertia: 0.266 kgm²
- Coupling data taken into account on LS Shaft:
 - o Weight: 87.5 kg
 - o Center of gravity position from shaft end: 40.9 mm
 - o Inertia: 0.875 kgm²

Including :

- Customer witness of test
- After test disassembly and inspection
- Noise level test report
- Lateral analysis undamped
- Documentation : downloadable electronic file in english

Instrumentation (see the complete package on additional technical data sheet):

- *Temperature package*
12 RTD's PT100 Duplex 3 wires from Thermo Electric Company Inc.
(2 per bearing and thrust bearing side) not wired with terminal heads..... Price included
- *Bently Nevada vibration package*
8 radial (4 per shaft) & 2 axial (on LS shaft) vibration probes, 2 accelerometers (1 per shaft), 2 keyphasors (1 per shaft) not wired..... Price included

Spare parts (Prices are net valid only if spares are ordered together with the gearbox):

- *Commissioning Spares*
2 RTD's, 2 BN vibration probes, 2 BN accelerometers 7 900 EUR Lot Net
- *2 Years Normal Operation Spares*
2 set of bearings with RTD's, 1 set of oil seals 48 420 EUR Lot Net
- *Strategic Spare Parts*
One complete set of rotating elements consisting of one pinion and one gear.
Tested if ordered together with the main gearbox according to AP1613/03
Full Speed, No Load, with Test Report..... 51 500 EUR Lot Net
- *Container for horizontal spare rotors storage painted according FG standard*..... 17 100 EUR Lot Net

SPECIAL PURPOSE GEAR UNITS
API 613 FIFTH EDITION
DATA SHEET SI UNITS

Job No. 41104 Item No. A
 P.O. No. _____ Date _____
 Revision No. _____
 Inquiry No. _____
 Revision 1 Date 09.03.2015 By HNI
 US Standards (1.7) ISO Standards (1.7)

Applicable To: Proposal Purchase As Built

1 For Siemens AG Duisburg
 2 Site Khursanlyah Al Fadhill
 3 Unit STC-SV 08-4-A
 4 Service EMCC
 5 No. required 9

Manufacturer FLENDER-GRAFFENSTADEN
 Model No. TX5014C
 Serial No. _____
 Driver type electric motor
 Driven equipment centrifugal compressor

Information to be completed by purchaser

Information to be completed by manufacturer

UNITS OF MEASUREMENT

BASIC GEAR DATA

US Customary units
 SI units

RATING REQUIREMENTS

Single stage Single helical
 Double stage Double helical
 Epicyclic horizontal offset

14 Driven equip. (2.1.4): Norm. _____ Max _____ kW
 15 Driver: Rated _____ Max _____ kW
 16 Normal transmitted power (2.2.2) _____ kW
 17 Gear unit rated power (2.2.1) _____ 6800 kW
 18 Torque @ max cont speed _____ Nm
 19 Max torque (2.2.1) _____ Nm @ _____ rpm
 20 Reducer Increaser
 21 Rated speed (2.1.5): _____ rpm
 22 Input _____ 1800 rpm Specified Nominal
 23 Output _____ 7285 rpm Specified Nominal
 24 Allow var in gear ratio (2.1.5) (+) (-) _____ %
 25 Max continuous speed (1.5) _____ 1800 / 7285 rpm
 26 Trip speed (1.5) (2.1.7) _____ 1980 / 8013.5 rpm
 27 Gear service factor (2.2.3.1) _____ 1.4 API 613/2003 5 TH (min)
 28 Hardness (2.2.3.2) Pinion _____ Gear _____
 29 Shaft assembly designation (2.1.19) _____ L/R
 30 HS shaft rot fac'g cpl'g (2.1.20.2) CW CCW
 31 LS shaft rot fac'g cpl'g (2.1.20.2) CW CCW
 32 External loads (2.1.16) _____
 33 Other operating conditions (2.2.2) (2.6.1.3) _____
 34
 35 **INSTALLATION DATA (2.1.14)**
 36 Indoor Heated Under roof
 37 Outdoor Unheated Partial sides
 38 Grade Mezzanine ONSHORE
 39 Winterization required Tropicalization required
 40 Electrical area (2.1.10) Class _____ GIP _____ DIV _____
 41 Electrical area (2.1.10) Zone 2 GIP IIA Temp T1 °C
 42 Max allow SPL (2.1.6) _____ dB(A) @ _____ m
 43 Elevation _____ m Barometer _____ kPa abs
 44 Range of ambient temperatures: _____
 45 _____ Dry bulb _____ Wet bulb
 46 Normal _____ °C
 47 Maximum _____ 82 °C
 48 Minimum _____ 0 °C
 49 Unusual conditions Dust Furnes
 50

Mechanical rating (1.5.16) _____ 9520 kW @ 1800 / 7309.1 rpm
 Gear service factor (2.2.3.1) _____ 1.44 API 613/2003 5 TH (actual)
 Full load gear unit power loss _____ 66 kW
 Gear Unit Mechanical efficiency _____ 99.03 %
 Rating speed Pinion _____ 7,309.1 Gear _____ 1,800.0 rpm
 Hardness used for _____
 Rating (HB or Rc) Pinion _____ 58 HRC Gear _____ 58 HRC
 Tooth pitting index, K_v (2.2.4.1) (2.2.4.2) _____
 Allowable _____ 2.17 Actual _____ 2.10 MPa
 Material index number (Fig 3, Table 4) _____ 3.03 MPa
 Bending stress number, S_t (2.2.5.1) (2.2.5.2) _____
 Pinion: Allowable _____ 265.4 Actual _____ 266.0 MPa
 Gear: Allowable _____ 265.4 Actual _____ 249.9 MPa
 Pitch line velocity _____ 77.1 m/s
 Anticipated SPL (2.1.6) _____ 82 dB(A) @ _____ 1 m
 WR^2 referred to LS shaft _____ 126.12 kgm²
 Breakaway torque _____ 412 Nm @ LS Shaft
 Pinion teeth hardness range _____ 58 - 63 HRC
 Pinion teeth hardening method _____ CARBURIZED
 HS shaft separate hardness range _____
 Gear teeth (fin) hardness range _____ 58 - 63 HRC
 Gear teeth hardening method _____ CARBURIZED
 Gear hub: _____
 Forged cylinder Forged & Copped Fabricated
 Gear to Shaft fit method (2.5.3.2) _____
 Integral Keyed interference Keyless interference
 Rim attachment (2.5.3.2) _____ FORGED GEAR WHEEL
 LS shaft hardness range _____ HB 230 - 274
 Journal static weight loads (2.6.6.3) _____
 Pinion _____ 128 / 42 kg Gear _____ 942 / 707 kg
 Total gear unit assembled weight _____ 4000 kg
 NOTES: _____
 _____ / 11

SPECIAL PURPOSE GEAR UNITS
API 613 FIFTH EDITION
DATA SHEET SI UNITS

Job No. 41104 Item No. A
P.O. No. _____ Date _____
Requisition No. _____
Inquiry No. _____
Revision 1 Date 06.03.2015 By HNI

■ GEAR DATA				○ COUPLINGS AND GUARDS		
	Pinion	Gear		Pinion	Gear	
Number of teeth	33	134		Coupling furnished by (3.2.1)	Compr. Supplier	Compr. Supplier
Gear ratio	4,06			Mount coupling halves (3.2.2)	Compr. Supplier	Compr. Supplier
Tangential load, "Wt" (2.2.4.2)	88.155		N	Cplg. guard adapter by (3.2.3)	Gear Supplier	Gear Supplier
AGMA Geometry factor "J"	0,55	0,57		Cplg. guard furnished by (3.2.3)	Compr. Supplier	Compr. Supplier
Pitch diameter	201,56	818,44	mm	Coupling vendor (3.2.3)		
Outside diameter	214,10	827,60	mm	Vendor's model number (3.2.3)		
Root diameter	187,25	800,74	mm	Coupling weight on shaft, kg	26,6	87,5
Center groove diameter	177,00	790,00	mm	CG inboard / outboard of shaft end	Outboard	Outboard
Normal pressure angle	20,00		deg	Hub drill template provided	<input type="checkbox"/>	<input type="checkbox"/>
Normal diametral pitch	4,62		in ⁻¹	■ SHAFT END DETAIL (2.5.4.2)		
Helix angle	25,00		deg	Shaft end detail specified by: <input checked="" type="radio"/> Purchaser <input type="radio"/> Gear vendor		
Center distance	510,00		mm	(Integral unless otherwise specified)		
Backlash min	0,34		mm	Shaft end detail if 'otherwise' specified:		
Net face width, "Fw"	260,00		mm	Tapered / Keyless	<input type="radio"/> <input type="checkbox"/>	<input type="radio"/> <input type="checkbox"/>
Pinion L/D	1,71			Tapered / 1-Key	<input type="radio"/> <input type="checkbox"/>	<input type="radio"/> <input type="checkbox"/>
Face overlap ratio	6,36			Tapered / 2-Keys	<input type="radio"/> <input type="checkbox"/>	<input type="radio"/> <input type="checkbox"/>
Transverse contact ratio	1,45			Cylindrical / 1-Key	<input type="radio"/> <input type="checkbox"/>	<input type="radio"/> <input type="checkbox"/>
AGMA 6011 service factor	2,64			Cylindrical / 2-Keys	<input type="radio"/> <input type="checkbox"/>	<input type="radio"/> <input type="checkbox"/>
Rating based on ANSIVAGMA 6011 with SF=1.0				Other <u>Flanged</u>	<input checked="" type="radio"/> <input type="checkbox"/>	<input checked="" type="radio"/> <input type="checkbox"/>
Durability Power	21442		kW	Shaft diameter	120,0	190,0 mm
Strength Power	17946		kW	(if integral flange use diameter immediately adjacent to flange)		
Tooth Surface Finish, Ra	0,4	0,4	µm	■ RADIAL BEARINGS		
Tooth Generation Process	Hobbling	Hobbling		Type	OFFSET / OFFSET	CYL. / CYL.
Tooth Finishing Process	Grinding	Grinding		Diameter	130 / 130	200 / 200 mm
Lead modification (2.2.4.6)	<input checked="" type="radio"/> Not Req'd	<input type="radio"/> Req'd		Length	130 / 130	100 / 100 mm
Calculated Total Lead Mismatch			µm	Journal velocity	49,8 / 49,8	18,8 / 18,8 m/s
■ SCUFFING DATA (2.2.6)				Loading	2,78 / 2,81	2,87 / 2,71 N/mm ²
Scuffing Data per ANSIVAGMA 926-A03				Clearance (min-max)		
Scuffing Risk (2.2.6) <u><=5% (Low)</u>	Calculation Method	<u>AGMA925</u>		Span	550	550 mm
Composite surface roughness, σx	0,57		µm	Power loss each bearing	13,8 / 13,8	3,0 / 3,0 kW
Specific film thickness, EHL λmin	3,31		µm	Oil flow each bearing	42,0 / 42,0	10,0 / 10,0 l/min
Tooth temperature, θm	82		°C	■ THRUST BEARINGS		
Maximum contact temperature, θBmax	101		°C	Location	<u>OPP.CPLG.SIDE</u>	
■ MATERIALS				Manufacturer	<u>FLENDER</u>	
Gear casing	Steel	Oil seals	aluminum	Type	<u>NO</u>	
Pinion(s)	<u>18CrNiMo7-6</u>			Size	<u>COMB.TAP.LANDS</u>	
Gear rim(s)	<u>18CrNiMo7-6</u>			Area	<u>11615</u> mm ²	
HS Shaft	Integral	LS Shaft	<u>42CrMo4</u>	Loading	<u>1,14</u> MPa	
Radial bearings	Babbitt	Backing	Steel	Rating	<u>1,50</u> MPa	
Thrust bearing(s)	Babbitt	Backing	Steel	Int. thrust load		
				Ext. thrust load	4.050	9.200 N
○ SHAFT END DETAIL				Power loss each	0,0	6,0 kW
<input checked="" type="checkbox"/> Gear shaft end for coupling integral flange (2.5.4.2)				Oil flow each bearing	0,0	20,0 l/min
<input checked="" type="checkbox"/> Pinion shaft end for coupling integral flange (2.5.4.2)				NOTES :		
<input checked="" type="checkbox"/> Other :	<u>WITHOUT BOLTS</u>					

SPECIAL PURPOSE GEAR UNITS
API 613 FIFTH EDITION
DATA SHEET SI UNITS

Job No. 41104 Item No. A
P.O. No. _____ Date _____
Requisition No. _____
Inquiry No. _____
Revision 1 Date 06.03.2015 By HNI

<p>○ LUBRICATION REQUIREMENTS</p> <p><input type="checkbox"/> Oil system furnished by (2.8.3) _____</p> <p><input type="checkbox"/> Other _____ <input type="checkbox"/> Gear vendor _____</p> <p><input type="checkbox"/> Oil visc. _____ cp @ 40°C _____ cp @ 100°C (2.8.6)</p> <p><input type="checkbox"/> ISO Grade _____ Load stage (2.2.6) <u>5,0</u></p> <hr/> <p style="text-align: center;">■ MESH</p> <p>Mesh and windage power loss <u>26,4</u> kW</p> <p>Oil flow, mesh <u>40,0</u> l/min</p> <hr/> <p style="text-align: center;">■ LUBRICATION REQUIREMENTS</p> <p>Min. startup oil temperature <u>20,0</u> °C</p> <p>Normal oil inlet temperature <u>60,0</u> °C</p> <p>Maximum oil inlet temperature <u>65,0</u> °C</p> <p>Unit oil flow (total) <u>164,0</u> l/min</p> <p>Unit oil pressure <u>2,5</u> bar</p> <p><input type="checkbox"/> Oil visc. _____ cp @ 40°C _____ cp @ 100°C (2.8.6)</p> <p><input type="checkbox"/> ISO Grade <u>46</u> Load stage (2.2.6) <u>5,0</u></p> <hr/> <p style="text-align: center;">■ PIPING CONNECTIONS</p> <table border="1" style="width:100%; border-collapse: collapse;"> <thead> <tr> <th>Service</th> <th>No.</th> <th>Size</th> <th>Type</th> </tr> </thead> <tbody> <tr> <td>Lube oil inlet</td> <td>1</td> <td>2 in.</td> <td>ANSI 150 LBS</td> </tr> <tr> <td>Lube oil outlet</td> <td>1</td> <td>6 in.</td> <td>ANSI 150 LBS</td> </tr> <tr> <td>Casing drain *</td> <td></td> <td></td> <td></td> </tr> <tr> <td>Vent</td> <td>1</td> <td>1,5 in.</td> <td>ANSI 150 LBS</td> </tr> <tr> <td>Casing purge</td> <td></td> <td></td> <td></td> </tr> </tbody> </table> <p>* Casing drain is 'dead bottom' housing drain, not lube oil outlet</p> <hr/> <p style="text-align: center;">○ MOUNTING PLATES</p> <p><input type="checkbox"/> Gear furnished with (3.3.1.1)</p> <p><input type="checkbox"/> Baseplate <input type="checkbox"/> Soleplate <input type="checkbox"/> Subplate(s) (3.3.2.10)</p> <p><input type="checkbox"/> Mounting plates(s) furnished by (3.3.1.1) _____</p> <p><input type="checkbox"/> Baseplate leveling (3.3.2.3) _____</p> <p><input type="checkbox"/> Baseplate with leveling pads (3.3.2.3)</p> <p><input type="checkbox"/> Baseplate suitable for column mounting (3.3.2.4)</p> <p><input type="checkbox"/> Vendor review of purchaser's foundation dwgs. (2.1.13)</p> <p><input type="checkbox"/> Grout type (3.3.1.2.4) _____</p> <hr/> <p style="text-align: center;">○ CONTRACT DATA</p> <p><input type="checkbox"/> Test data prior to shipment _____</p> <p><input checked="" type="checkbox"/> Progress report (5.3.3) _____</p> <p><input type="checkbox"/> Vendor signoff of inspector checklist (4.1.1.3)</p> <p><input checked="" type="checkbox"/> Information retained for 20 years (4.2.1.1) (4.2.2.6.1)</p> <p><input type="checkbox"/> Technical manual (5.3.5.4)</p> <p><input checked="" type="checkbox"/> PAINTING (4.4.3.1) <input checked="" type="checkbox"/> <u>Flender standard RAL5015 (blue)</u></p> <p><input checked="" type="checkbox"/> Painting housing interior not allowed (2.3.1.14)</p> <hr/> <p style="text-align: center;">○ SHIPMENT</p> <table border="1" style="width:100%; border-collapse: collapse;"> <thead> <tr> <th></th> <th>Contract unit</th> <th>Spares</th> </tr> </thead> <tbody> <tr> <td>Export boxing</td> <td><input type="checkbox"/></td> <td><input type="checkbox"/></td> </tr> <tr> <td>Domestic boxing</td> <td><input type="checkbox"/></td> <td><input type="checkbox"/></td> </tr> <tr> <td>Outdoor storage over 6 mos.</td> <td><input type="checkbox"/></td> <td>3 years indoor <input type="checkbox"/> (4.4.3.8)</td> </tr> </tbody> </table>	Service	No.	Size	Type	Lube oil inlet	1	2 in.	ANSI 150 LBS	Lube oil outlet	1	6 in.	ANSI 150 LBS	Casing drain *				Vent	1	1,5 in.	ANSI 150 LBS	Casing purge					Contract unit	Spares	Export boxing	<input type="checkbox"/>	<input type="checkbox"/>	Domestic boxing	<input type="checkbox"/>	<input type="checkbox"/>	Outdoor storage over 6 mos.	<input type="checkbox"/>	3 years indoor <input type="checkbox"/> (4.4.3.8)	<p>○ ADDITIONAL REQUIREMENTS</p> <p style="text-align: center;">○ VIBRATION DETECTORS</p> <p>RADIAL (3.4.2.1) (2.7.4.5) (2.7.4.6)</p> <p><input checked="" type="checkbox"/> Manufacturer <u>BENTLY NEVADA</u> <input checked="" type="checkbox"/> Total No. <u>8</u></p> <p><input checked="" type="checkbox"/> X-Y probes pinion bearings <input checked="" type="checkbox"/> Coupling end <input checked="" type="checkbox"/> Blind end</p> <p><input checked="" type="checkbox"/> X-Y probes gear bearings <input checked="" type="checkbox"/> Coupling end <input checked="" type="checkbox"/> Blind end</p> <p><input type="checkbox"/> Other _____</p> <p>AXIAL (3.4.2.1) (2.7.4.5) (2.7.4.6)</p> <p><input checked="" type="checkbox"/> Manufacturer <u>BENTLY NEVADA</u> <input checked="" type="checkbox"/> Total No. <u>2</u></p> <p><input type="checkbox"/> Dual probes at each thrust bearing</p> <p><input type="checkbox"/> Single probe any shaft without thrust bearing</p> <p><input type="checkbox"/> Other _____</p> <p>ONE EVENT PER REVOLUTION PROBE (2.7.4.5) (2.7.4.6)</p> <p><input checked="" type="checkbox"/> Manufacturer <u>BENTLY NEVADA</u> Total No. <u>2</u></p> <p><input checked="" type="checkbox"/> One on input shaft <input checked="" type="checkbox"/> One on output shaft</p> <p><input type="checkbox"/> Other _____</p> <p>ACCELEROMETER (3.4.2.1) (2.7.4.5) (2.7.4.6)</p> <p><input checked="" type="checkbox"/> Manufacturer <u>BENTLY NEVADA</u> <input checked="" type="checkbox"/> No. required <u>2</u></p> <p><input checked="" type="checkbox"/> Pinion coupling end <input checked="" type="checkbox"/> Gear coupling end</p> <p><input type="checkbox"/> Other _____</p> <hr/> <p style="text-align: center;">○ TEMPERATURE DETECTORS</p> <p><input type="checkbox"/> Dial type thermometers (3.4.2.7) _____</p> <p><input checked="" type="checkbox"/> Type brg. temp. sensors (3.4.2.7) (2.7.1.3) <u>PT100</u></p> <p><input type="checkbox"/> RTD <input type="checkbox"/> Thermocouple / <input type="checkbox"/> Simplex <input checked="" type="checkbox"/> Duplex</p> <p>Calibration <u>Yes</u></p> <p><input checked="" type="checkbox"/> HSLS bearings no. sensors each <u>2</u> / <u>2</u></p> <p><input checked="" type="checkbox"/> Thrust number of sensing elements each face <u>2</u></p> <hr/> <p style="text-align: center;">○ OTHER VIBRATION AND TEMPERATURE</p> <table border="1" style="width:100%; border-collapse: collapse;"> <thead> <tr> <th>(3.4.2.5) (3.4.2.6)</th> <th>Other</th> <th>Gear vendor</th> </tr> </thead> <tbody> <tr> <td>Oscillator demodulator supplied by</td> <td><input type="checkbox"/></td> <td><input checked="" type="checkbox"/></td> </tr> <tr> <td>Vibration monitor supplied by</td> <td><input checked="" type="checkbox"/></td> <td><input type="checkbox"/></td> </tr> <tr> <td>Vibration shutdown delay time _____ seconds</td> <td></td> <td></td> </tr> <tr> <td>Temperature monitor supplied by</td> <td><input checked="" type="checkbox"/></td> <td><input type="checkbox"/></td> </tr> <tr> <td>Oscillator demodulator J-box by</td> <td><input checked="" type="checkbox"/></td> <td><input type="checkbox"/></td> </tr> <tr> <td>Temp. sensor termination J-box by</td> <td><input checked="" type="checkbox"/></td> <td><input type="checkbox"/></td> </tr> <tr> <td>J-box type _____ Mount _____</td> <td></td> <td></td> </tr> </tbody> </table> <hr/> <p style="text-align: center;">○ MISCELLANEOUS</p> <p><input checked="" type="checkbox"/> Undamped critical analysis report (2.6.2.1)</p> <p><input type="checkbox"/> w/ dampd rotr respsn analys rpt (2.6.2.4.3) (2.6.2.6)</p> <p>Torsional analysis by (2.6.5.2) <input type="checkbox"/> Gear vendor <input checked="" type="checkbox"/> Other</p> <p><input type="checkbox"/> Spare set of gear rotors (4.3.2.4)</p> <p><input type="checkbox"/> Gear case furnished with inlet purge connection (2.4.3)</p> <p><input type="checkbox"/> Orientation of oil inlet & drain conns. (2.4.6)</p> <p><input checked="" type="checkbox"/> Filter breather location (2.3.1.12) <u>Prov. on upper casing</u></p> <p><input type="checkbox"/> Torsional device provisions (2.5.4.5)</p> <p><input type="checkbox"/> Rotor vertical storage provisions (2.5.4.8)</p> <p><input type="checkbox"/> Rotor vertical storage fixture(s) (3.6.2)</p> <p><input type="checkbox"/> Vendor service rep. on site (2.1.13)</p>	(3.4.2.5) (3.4.2.6)	Other	Gear vendor	Oscillator demodulator supplied by	<input type="checkbox"/>	<input checked="" type="checkbox"/>	Vibration monitor supplied by	<input checked="" type="checkbox"/>	<input type="checkbox"/>	Vibration shutdown delay time _____ seconds			Temperature monitor supplied by	<input checked="" type="checkbox"/>	<input type="checkbox"/>	Oscillator demodulator J-box by	<input checked="" type="checkbox"/>	<input type="checkbox"/>	Temp. sensor termination J-box by	<input checked="" type="checkbox"/>	<input type="checkbox"/>	J-box type _____ Mount _____		
Service	No.	Size	Type																																																										
Lube oil inlet	1	2 in.	ANSI 150 LBS																																																										
Lube oil outlet	1	6 in.	ANSI 150 LBS																																																										
Casing drain *																																																													
Vent	1	1,5 in.	ANSI 150 LBS																																																										
Casing purge																																																													
	Contract unit	Spares																																																											
Export boxing	<input type="checkbox"/>	<input type="checkbox"/>																																																											
Domestic boxing	<input type="checkbox"/>	<input type="checkbox"/>																																																											
Outdoor storage over 6 mos.	<input type="checkbox"/>	3 years indoor <input type="checkbox"/> (4.4.3.8)																																																											
(3.4.2.5) (3.4.2.6)	Other	Gear vendor																																																											
Oscillator demodulator supplied by	<input type="checkbox"/>	<input checked="" type="checkbox"/>																																																											
Vibration monitor supplied by	<input checked="" type="checkbox"/>	<input type="checkbox"/>																																																											
Vibration shutdown delay time _____ seconds																																																													
Temperature monitor supplied by	<input checked="" type="checkbox"/>	<input type="checkbox"/>																																																											
Oscillator demodulator J-box by	<input checked="" type="checkbox"/>	<input type="checkbox"/>																																																											
Temp. sensor termination J-box by	<input checked="" type="checkbox"/>	<input type="checkbox"/>																																																											
J-box type _____ Mount _____																																																													

**SPECIAL PURPOSE GEAR UNITS
API 613 FIFTH EDITION
DATA SHEET SI UNITS**

Job No.	41104	Item No.	A
P.O. No.		Date	
Requisition No.			
Inquiry No.			
Revision	1	Date	06.03.2015
By	HNI		

○ INSPECTIONS AND TESTS (4.1)				
1	<input type="checkbox"/> Advance notice of witness testing required (4.1.3)			
2	Number calendar days _____			
3		Req'd	Witness	Observe
4				Test Log
5				
6	Shop Inspection (4.1.1)	<input type="checkbox"/>	<input type="checkbox"/>	<input type="checkbox"/>
7	Cleanliness Inspection (4.2.3.1)	<input type="checkbox"/>	<input type="checkbox"/>	<input type="checkbox"/>
8	Hardness Verification (4.2.3.3)	<input checked="" type="checkbox"/>	<input type="checkbox"/>	<input checked="" type="checkbox"/>
9	Dismantle-reassembly (4.3.2.3.1)	<input checked="" type="checkbox"/>	<input type="checkbox"/>	<input type="checkbox"/>
10	Contact Check (2.5.2.2)	<input checked="" type="checkbox"/>	<input type="checkbox"/>	<input type="checkbox"/>
11	Contact Check Tape Lift (2.5.2.2)	<input checked="" type="checkbox"/>	<input type="checkbox"/>	<input checked="" type="checkbox"/>
12	Gear accuracy check (2.5.2.1)	<input checked="" type="checkbox"/>	<input type="checkbox"/>	<input type="checkbox"/>
13	Double helical axial stability (2.5.2.3)	<input checked="" type="checkbox"/>	<input type="checkbox"/>	<input checked="" type="checkbox"/>
14	Special testing Integral forged gears (2.5.3.3)			
15	(testing per mutual agreement)	<input type="checkbox"/>	<input type="checkbox"/>	<input type="checkbox"/>
16	Residual unbalance check (2.6.6.2)	<input checked="" type="checkbox"/>	<input type="checkbox"/>	<input checked="" type="checkbox"/>
17	Mechanical Run Test (Main) (4.3.2)	<input checked="" type="checkbox"/>	<input type="checkbox"/>	<input checked="" type="checkbox"/>
18	Mechanical Run Test (Spare) (4.3.2.4)	<input type="checkbox"/>	<input type="checkbox"/>	<input type="checkbox"/>
19	Adft. Mechanical Tests (4.3.2.2.16)	<input type="checkbox"/>	<input type="checkbox"/>	<input type="checkbox"/>
20	Part or Full Load And Full Speed			
21	Test (4.3.3.1)	<input type="checkbox"/>	<input type="checkbox"/>	<input type="checkbox"/>
22	Full torque, reduced speed (4.3.3.2)	<input type="checkbox"/>	<input type="checkbox"/>	<input type="checkbox"/>
23	Full Torque Static Test (4.3.3.3)	<input type="checkbox"/>	<input type="checkbox"/>	<input type="checkbox"/>
24	Back-To-Back Locked Torque			
25	Test (4.3.3.4)	<input type="checkbox"/>	<input type="checkbox"/>	<input type="checkbox"/>
26	Sound Level Test (4.3.3.5)	<input checked="" type="checkbox"/>	<input type="checkbox"/>	<input checked="" type="checkbox"/>
27	Additional gear tooth test (4.2.2.8)	<input type="checkbox"/>	<input type="checkbox"/>	<input type="checkbox"/>
28	Use shop Lube System	<input checked="" type="checkbox"/>	<input type="checkbox"/>	<input type="checkbox"/>
29	Use job lube system	<input type="checkbox"/>	<input type="checkbox"/>	<input type="checkbox"/>
30	Use shop Vibration Probes, Etc.	<input type="checkbox"/>	<input type="checkbox"/>	<input type="checkbox"/>
31	Use job Vibration Probes, Etc.	<input checked="" type="checkbox"/>	<input type="checkbox"/>	<input type="checkbox"/>
32	Final Assembly, Maintenance &			
33	Running Clearance (4.2.1.1.e)	<input checked="" type="checkbox"/>	<input type="checkbox"/>	<input checked="" type="checkbox"/>
34	Oil System Cleanliness (4.2.3.2)	<input type="checkbox"/>	<input type="checkbox"/>	<input type="checkbox"/>
35	Oil System-Casing Joint			
36	Tightness (4.3.2.1.4)	<input type="checkbox"/>	<input type="checkbox"/>	<input type="checkbox"/>
37	Warning And Protection			
38	Devices (4.3.2.1.5)	<input type="checkbox"/>	<input type="checkbox"/>	<input type="checkbox"/>
39	Seismic Vibration Data (4.3.2.2.3)	<input type="checkbox"/>	<input type="checkbox"/>	<input type="checkbox"/>
40	Vibration, Phase Plots (4.3.2.2.12)	<input checked="" type="checkbox"/>	<input type="checkbox"/>	<input checked="" type="checkbox"/>
41	Oil inlet Range test (4.3.2.2.13)	<input type="checkbox"/>	<input type="checkbox"/>	<input type="checkbox"/>
42	Tape recorded Vibration Data	<input checked="" type="checkbox"/>	<input type="checkbox"/>	<input checked="" type="checkbox"/>
43	(4.3.2.2.14) (4.3.2.2.15)	<input type="checkbox"/>	Purchaser copy	
44	NON-DESTRUCTIVE TESTING (4.2.1.2) (4.2.2.1)			
45		Surface	Sub surface	Log
46	<input type="checkbox"/> Casing	<input type="checkbox"/>	<input type="checkbox"/>	<input type="checkbox"/>
47	<input checked="" type="checkbox"/> Rot. Elmts.	<input checked="" type="checkbox"/>	<input checked="" type="checkbox"/>	<input checked="" type="checkbox"/>
48	<input checked="" type="checkbox"/> Bearings	<input checked="" type="checkbox"/>	<input checked="" type="checkbox"/>	<input checked="" type="checkbox"/>
49	<input type="checkbox"/> Other :	<input type="checkbox"/>	<input type="checkbox"/>	<input type="checkbox"/>
50	(Specify)			

NOTES:

During start-up, gears can exhibit a transient spike reading of vibration levels that will exceed shutdown settings. Therefore a trip multiplier is recommended in the control system.

Mechanical running test duration 4 hours including
 - Shaft vibration record using job vibration probes if ordered
 - Bearings temperature records
 - Casing vibration measurement
 - Sound level pressure measurement
 - Power losses measurement at oil outlet
 - Performed with oil ISO VG 32

Oil flow requirement and power losses are calculated values only, add normal safety margins for sizing heat exchangers.

PRELIMINARY MASS ELASTIC DATA

Customer : Siemens AG Duisburg
 Destination : Khursariyah Al Fadhili
 Purchaser order :
 F-G job number : D 41104A1 OL
 Type and serial N° : TX50/4C

Power rating : 6800 kW
 Service factor : AP1613/03 $\geq 1,4$
 Input speed : 1800 rpm
 Output speed : 7309,1 rpm
 Speed ratio : 4,06

Weight HSS : 143,5 kg
 Weight pos. from teeth middle HSS : 63,4 mm
 Inertia HSS : 0,585 Kg.m²
 Stiffness HSS : 5,916 MN/m/rad
 Bearing type 1 : Offset 130 x 130
 Bearing type 2 : Offset 130 x 130
 Add. weight on brg. side 1 : 26,6 kg

Weight LSS : 1561,2 kg
 Weight pos. from teeth middle LSS : 10,5 mm
 Inertia LSS : 116,473 Kg.m²
 Stiffness LSS : 39,014 MN/m/rad
 Bearing type 4 : Cylindrical 200 x 100
 Bearing type 3 : Cylindrical 200 x 100
 Add. weight on brg. side 4 : 87,5 kg

Positive direction of external

APPAREIL.xls _ Edition du :06.03.2015
 1/1

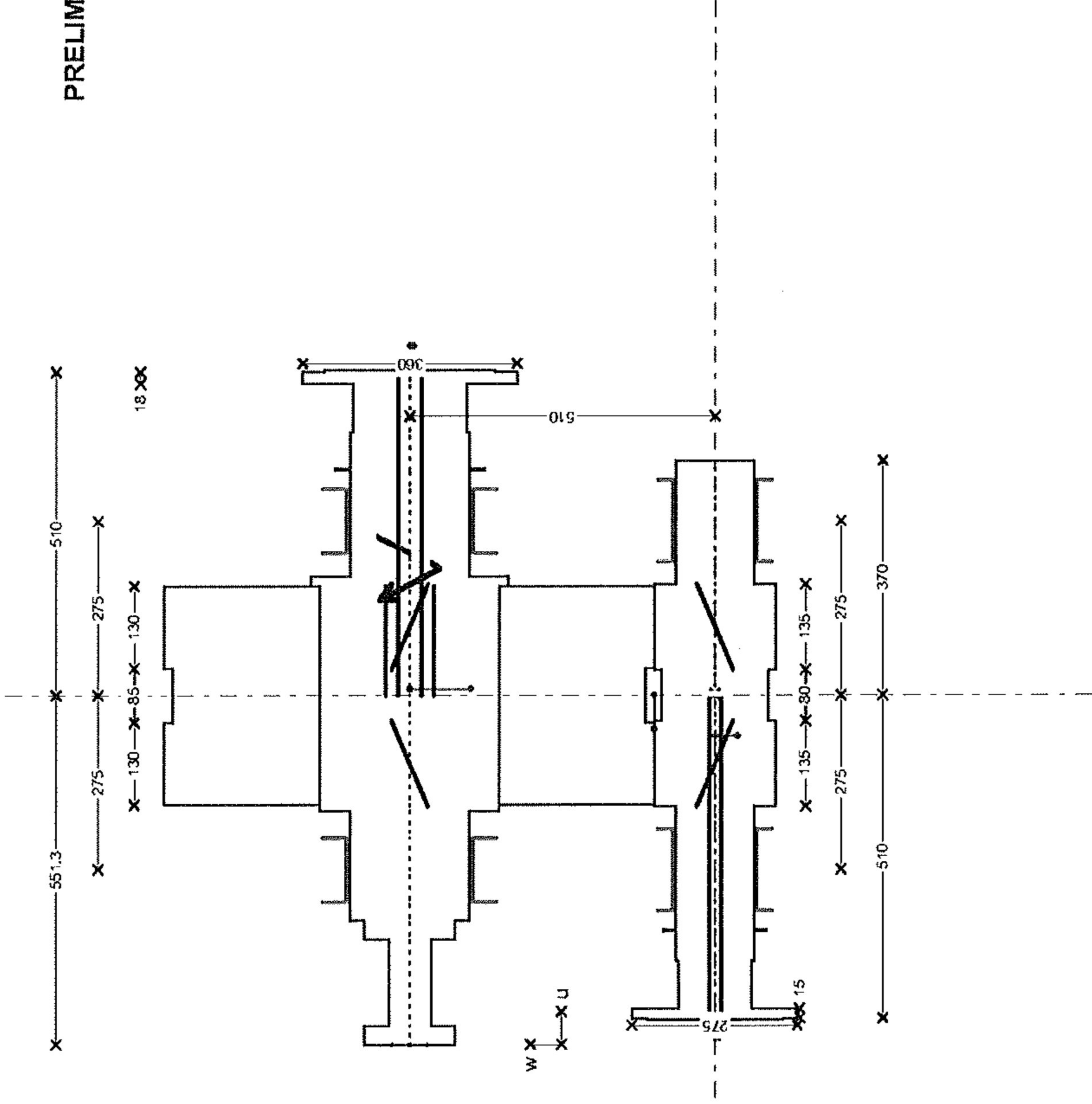

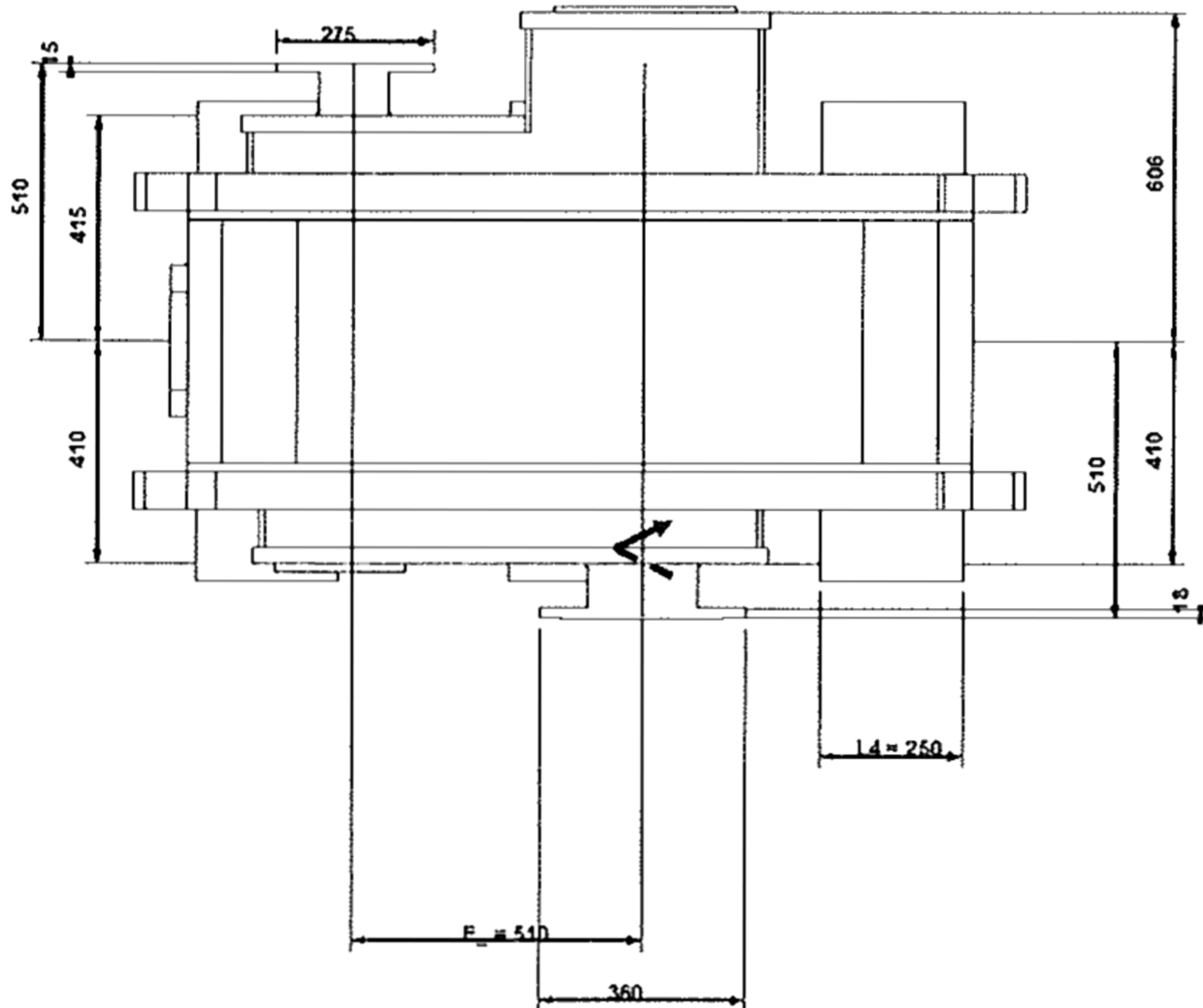
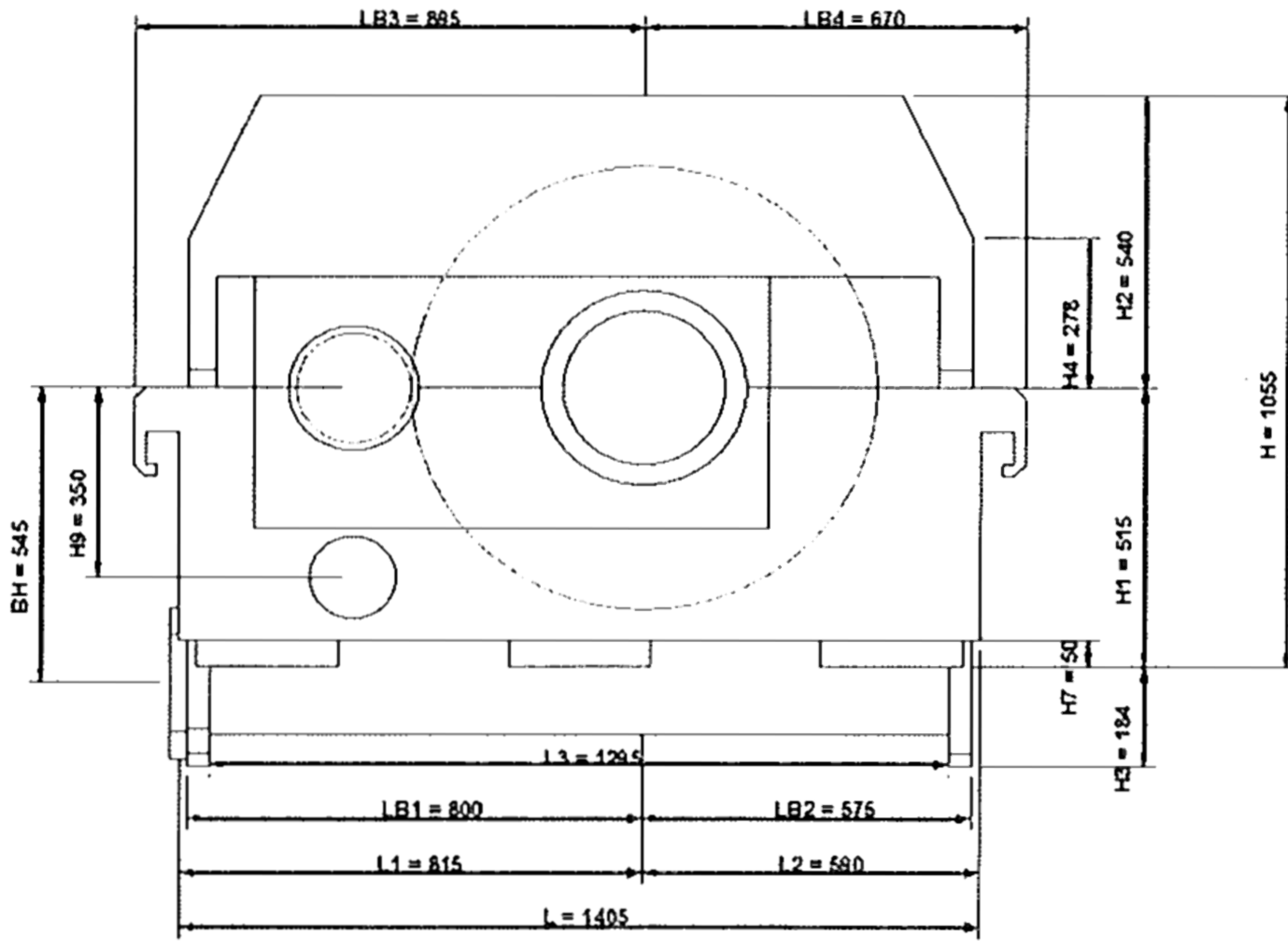

ADDITIONAL TECHNICAL DATASHEET		Job No. <u>41104</u> Item No. <u>A</u>																																			
		P.O. No. _____ Date _____																																			
		Requisition No. _____																																			
		Inquiry No. _____																																			
		Revision <u>1</u> Date <u>06.03.2016</u> By <u>HNI</u>																																			
<input checked="" type="checkbox"/> ADDITIONAL GEAR DATA		<input type="checkbox"/> TURNING GEAR (Dimensioning is preliminary !)																																			
Efficiency		Calculation results																																			
<table border="1" style="width:100%; border-collapse: collapse;"> <thead> <tr> <th>Percent of rated power</th> <th>Efficiency</th> </tr> </thead> <tbody> <tr> <td>100%</td> <td style="text-align: center;">99,03</td> </tr> <tr> <td>75%</td> <td style="text-align: center;">98,92</td> </tr> <tr> <td>50%</td> <td style="text-align: center;">98,79</td> </tr> <tr> <td>25%</td> <td style="text-align: center;">98,08</td> </tr> <tr> <td>10%</td> <td style="text-align: center;">90,80</td> </tr> </tbody> </table>		Percent of rated power	Efficiency	100%	99,03	75%	98,92	50%	98,79	25%	98,08	10%	90,80	Required turning speed _____ rpm Actual turning speed _____ rpm Required breakaway torque _____ Nm Actual breakaway torque _____ Nm Actual maximum torque _____ Nm Actual acceleration time _____ s																							
Percent of rated power	Efficiency																																				
100%	99,03																																				
75%	98,92																																				
50%	98,79																																				
25%	98,08																																				
10%	90,80																																				
Losses		Motor																																			
Power loss at no load _____ kW Heat rejection _____ kcal/h		Supplier _____ Power _____ kW Voltage _____ V Frequency _____ Hz Speed _____ rpm Electric standard _____																																			
<input type="checkbox"/> PUMP DETAILS (Dimensioning is preliminary !)																																					
Design : _____ Speed : _____ rpm Oil flow : _____ l/min Oil pressure : _____ bar NPSH : _____ m Safety valve : _____ Driving method : _____ Material : _____ Flanges : _____ Testing : _____ Furniture of ATEX certificate : _____		Turning gear Type _____ Ratio _____																																			
		Clutch																																			
		Type _____ Max. allowable torque _____ Nm																																			
		Miscellaneous																																			
		Starting device _____ Switch details _____																																			
<input checked="" type="checkbox"/> INSTRUMENTATION PACKAGE																																					
Thermometer		Thermoelements																																			
<table border="1" style="width:100%; border-collapse: collapse;"> <thead> <tr> <th></th> <th>Bearing</th> <th>Thrust bearing</th> <th>Oil inlet/outlet</th> </tr> </thead> <tbody> <tr> <td>Qty</td> <td></td> <td></td> <td></td> </tr> <tr> <td>Type</td> <td></td> <td></td> <td></td> </tr> </tbody> </table>			Bearing	Thrust bearing	Oil inlet/outlet	Qty				Type				<table border="1" style="width:100%; border-collapse: collapse;"> <thead> <tr> <th></th> <th>Bearing</th> <th>Thrust bearing</th> <th>Oil inlet/outlet</th> </tr> </thead> <tbody> <tr> <td>Type</td> <td>DUPLEX 2x3F</td> <td>DUPLEX 2x3F</td> <td></td> </tr> <tr> <td>Classification</td> <td>IEC60751</td> <td>IEC60751</td> <td></td> </tr> <tr> <td>Removable from the outside</td> <td>NO</td> <td>NO</td> <td></td> </tr> <tr> <td>ATEX</td> <td>ATEX Eexia</td> <td>ATEX Eexia</td> <td></td> </tr> </tbody> </table>		Bearing	Thrust bearing	Oil inlet/outlet	Type	DUPLEX 2x3F	DUPLEX 2x3F		Classification	IEC60751	IEC60751		Removable from the outside	NO	NO		ATEX	ATEX Eexia	ATEX Eexia				
	Bearing	Thrust bearing	Oil inlet/outlet																																		
Qty																																					
Type																																					
	Bearing	Thrust bearing	Oil inlet/outlet																																		
Type	DUPLEX 2x3F	DUPLEX 2x3F																																			
Classification	IEC60751	IEC60751																																			
Removable from the outside	NO	NO																																			
ATEX	ATEX Eexia	ATEX Eexia																																			
Shaft vibrations																																					
<table border="1" style="width:100%; border-collapse: collapse;"> <thead> <tr> <th></th> <th>Radial</th> <th>Axial</th> <th>Keyphasor</th> <th>Accelerometer</th> </tr> </thead> <tbody> <tr> <td>Type</td> <td>B N. 3300 XL 8mm Sys 9M</td> <td>HS No LS BENTLY NEVADA 3300 XL 8mm Sys 9M</td> <td>B N. 3300 XL 8mm Sys 9M</td> <td>ACCELEROMETER BENTLY</td> </tr> <tr> <td>Probe</td> <td>Yes</td> <td>HS No LS Yes</td> <td>Yes</td> <td></td> </tr> <tr> <td>Proximitior</td> <td>Yes</td> <td>HS No LS Yes</td> <td>Yes</td> <td style="background-color: #cccccc;"></td> </tr> <tr> <td>Probe holder</td> <td>Yes</td> <td>HS No LS Yes</td> <td>Yes</td> <td style="background-color: #cccccc;"></td> </tr> <tr> <td>Connection head</td> <td>Yes</td> <td>HS No LS Yes</td> <td>Yes</td> <td style="background-color: #cccccc;"></td> </tr> <tr> <td>mounting kit</td> <td style="background-color: #cccccc;"></td> <td style="background-color: #cccccc;"></td> <td style="background-color: #cccccc;"></td> <td>Yes</td> </tr> </tbody> </table>				Radial	Axial	Keyphasor	Accelerometer	Type	B N. 3300 XL 8mm Sys 9M	HS No LS BENTLY NEVADA 3300 XL 8mm Sys 9M	B N. 3300 XL 8mm Sys 9M	ACCELEROMETER BENTLY	Probe	Yes	HS No LS Yes	Yes		Proximitior	Yes	HS No LS Yes	Yes		Probe holder	Yes	HS No LS Yes	Yes		Connection head	Yes	HS No LS Yes	Yes		mounting kit				Yes
	Radial	Axial	Keyphasor	Accelerometer																																	
Type	B N. 3300 XL 8mm Sys 9M	HS No LS BENTLY NEVADA 3300 XL 8mm Sys 9M	B N. 3300 XL 8mm Sys 9M	ACCELEROMETER BENTLY																																	
Probe	Yes	HS No LS Yes	Yes																																		
Proximitior	Yes	HS No LS Yes	Yes																																		
Probe holder	Yes	HS No LS Yes	Yes																																		
Connection head	Yes	HS No LS Yes	Yes																																		
mounting kit				Yes																																	
Junction box(es)		Miscellaneous																																			
Qty _____ Manufacturer _____ Material _____ ATEX _____ None		Identification <input checked="" type="checkbox"/> wire <input checked="" type="checkbox"/> conduit <input type="checkbox"/> junction box Conduit type _____ Transmitter type _____ Qty _____ Terminal block type _____ Qty _____																																			

FLENDER GRAFFENSTADEN

FLENDER-GRAFFENSTADEN S.A., FRANCE
BP 84, F-67402 ILLKIRCH-CEDEX
1, rue du Vieux Moulin
F-67400 ILLKIRCH-GRAFFENSTADEN

Y/ref : Khursaniyah Al Fadhili - D43-K-3801 -
O/ref : D41104 quotation number 3

ITEM B 1 : Flender Graffenstaden (FG) High Speed increaser, model **TX40/5C**

- Rating conditions :

Rated power at **1620 kW**
Driven by a electric motor at **1800.0 rpm** (specified : 1800.0 rpm)
Driving a centrifugal compressor at **10737.9 rpm** (specified : 10736.0 rpm)
Service factor **1.47** according to **API613/03** (required : > 1.4)

- Technical description :

Double helical
Manufacturing according to API standard
Flange on LS shaft end
Flange on HS shaft end
Estimated Weight : 1900 kg

- Bearings description :

2 cylindrical bearings on LS shaft
2 tilting pads bearings on HS shaft
1 double acting tilting pad thrust bearing on low speed shaft non driven end

- *Mechanical running test* : Full speed, no load test during 4 hours according to the API 613 5th Edition standard.

- Lubrication conditions :

64 l/min of Oil ISO VG 46 at 60°C and 2.5 bar at inlet (calculated values only)

- Miscellaneous:

Efficiency at full load : 98.70 %
Power losses at full load : 21 kW (calculated value only)
Anticipated Sound Pressure Level: 82.0 ± 2dB(A) at 1 meter

Base price : 103 850 EUR each gear box

Delivery time : 36 weeks after the FG acknowledgement of the order

Quantity : 1 gearbox

Comments :

- Coupling data taken into account on HS Shaft:
 - o Weight: 10.4 Kg
 - o Center of gravity position from shaft end: 28.2 mm
 - o Inertia: 0.104 kgm²
- Coupling data taken into account on LS Shaft:
 - o Weight: 26.4 Kg
 - o Center of gravity position from shaft end: 30.9 mm
 - o Inertia: 0.264 kgm²

Including :

- Customer witness of test
- After test disassembly and inspection
- Noise level test report
- Lateral analysis undamped
- Documentation : downloadable electronic file in English

Instrumentation (see the complete package on additional technical data sheet):

- *Temperature package*
 - 12 RTD's PT100 Duplex 3 wires from Thermo Electric Company Inc.
(2 per bearing and thrust bearing side) not wired with terminal heads..... Price included
- *Bently Nevada vibration package*
 - 8 radial (4 per shaft) & 2 axial (on LS shaft) vibration probes, 2 accelerometers (1 per shaft), 2 keyphasors (1 per shaft) not wired Price included

Spare parts (Prices are net valid only if spares are ordered together with the gearbox):

- *Commissioning Spares*
 - 2 RTD's, 2 BN vibration probes, 2 BN accelerometers 7 900 EUR Lot Net
- *2 Years Normal Operation Spares*
 - 1 set of bearings with RTD's, 1 set of oil seals 26 010 EUR Lot Net
- *Strategic Spare Parts*
 - One complete set of rotating elements consisting of one pinion and one gear.
Tested if ordered together with the main gearbox according to API613/03
Full Speed, No Load, with Test Report..... 37 100 EUR Lot Net
- *Container for horizontal spare rotors storage painted according FG standard*..... 15 850 EUR Lot Net

SPECIAL PURPOSE GEAR UNITS
API 613 FIFTH EDITION
DATA SHEET SI UNITS

Job No. 41104 Item No. B
 P.O. No. _____ Date _____
 Requisition No. _____
 Inquiry No. _____
 Revision 1 Date 06.03.2015 By HNI

1 Applicable To: Proposal Purchase As Built
 2 For Siemens AG Duisburg Manufacturer FLENDER-GRAFFENSTADEN
 3 Site Khursaniyah Al Fadhili Model No. TX40/5C
 4 Unit STC-SV 06-3-A Serial No. _____
 5 Service EM/CC Driver type electric motor
 6 No. required 1 Driven equipment centrifugal compressor

NOTE : Numbers within () refer to applicable API standard 613 paragraphs

Information To be completed by purchaser

Information to be completed by manufacturer

UNITS OF MEASUREMENT
 US Customary units
 SI units

RATING REQUIREMENTS

14 Driven equip. (2.1.4): Norm. _____ Max _____ kW
 15 Driver: Rated _____ Max _____ kW
 16 Normal transmitted power (2.2.2) _____ kW
 17 Gear unit rated power (2.2.1) 1620 kW
 18 Torque @ max cont speed _____ Nm
 19 Max torque (2.2.1) _____ Nm @ _____ rpm
 Reducer Increaser
 21 Rated speed (2.1.5):
 22 Input 1800 rpm Specified Nominal
 23 Output 10736 rpm Specified Nominal
 24 Allow var in gear ratio (2.1.5) (+) (-) _____ %
 25 Max continuous speed (1.5) 1800 / 10736 rpm
 26 Trip speed (1.5) (2.1.7) 1980 / 11809,6 rpm
 27 Gear service factor (2.2.3.1) 1,4 API 613/2003 5 TH (min)
 28 Hardness (2.2.3.2) Pinion _____ Gear _____
 29 Shaft assembly designation (2.1.19) L/R
 30 HS shaft rot fac'g cpl'g (2.1.20.2) CW CCW
 31 LS shaft rot fac'g cpl'g (2.1.20.2) CW CCW
 32 External loads (2.1.16) _____
 33 Other operating conditions (2.2.2) (2.6.1.3) _____

INSTALLATION DATA (2.1.14)

36 Indoor Heated Under roof
 37 Outdoor Unheated Partial sides
 38 Grade Mezzanine **ONSHORE**
 39 Winterization required Tropicalization required
 40 Electrical area (2.1.10) Class _____ Grp _____ Div _____
 41 Electrical area (2.1.10) Zone 2 Grp IIA Temp T1 °C
 42 Max allow SPL (2.1.6) _____ dB(A) @ _____ m
 43 Elevation _____ m Barometer _____ kPa abs
 44 Range of ambient temperatures:
 45 Dry bulb _____ Wet bulb _____
 46 Normal _____ °C _____ °C
 47 Maximum 82 °C _____ °C
 48 Minimum 0 °C _____ °C
 49 Unusual conditions Dust Fumes
 50

BASIC GEAR DATA

Single stage Single helical
 Double stage Double helical
 Epicyclic horizontal offset

Mechanical rating (1.5.16) 2268 kW @ 1800 / 10737,9 rpm
 Gear service factor (2.2.3.1) 1,46 API 613/2003 5 TH (actual)
 Full load gear unit power loss 21 kW
 Gear Unit Mechanical efficiency 98,70 %
 Rating speed Pinion 10.737,9 Gear 1.800,0 rpm
 Hardness used for
 Rating, (HB or Rc) Pinion 58 HRC Gear 58 HRC
 Tooth pitting index, "K" (2.2.4.1) (2.2.4.2)
 Allowable 2,17 Actual 2,06 MPa
 Material index number (Fig 3, Table 4) 3,03 MPa
 Bending stress number, "S_t" (2.2.5.1) (2.2.5.2)
 Pinion: Allowable 265,4 Actual 251,0 MPa
 Gear: Allowable 265,4 Actual 238,8 MPa
 Pitch line velocity 63,0 m/s
 Anticipated SPL (2.1.6) 82 dB(A) @ 1 m
 WR² referred to LS shaft 29,88 kgm²
 Breakaway torque 90 Nm @ LS Shaft
 Pinion teeth hardness range 58 - 63 HRC
 Pinion teeth hardening method CARBURIZED
 HS shaft separate hardness range _____
 Gear teeth (rim) hardness range 58 - 63 HRC
 Gear teeth hardening method CARBURIZED
 Gear hub:
 Forged cylinder Forged & Copied Fabricated
 Gear to Shaft fit method (2.5.3.2)
 Integral Keyed interference Keyless interference
 Rim attachment (2.5.3.2) FORGED GEAR WHEEL
 LS shaft hardness range HB 230 - 274
 Journal static weight loads (2.6.6.3)
 Pinion 37 / 4 kg Gear 347 / 253 kg
 Total gear unit assembled weight 1900 kg
 NOTES: _____

SPECIAL PURPOSE GEAR UNITS
API 613 FIFTH EDITION
DATA SHEET SI UNITS

Job No.	41104	Item No.	B
P.O. No.		Date	
Requisition No.			
Inquiry No.			
Revision	1	Date	06.03.2015 By HNI

○ COUPLINGS AND GUARDS		
	Pinion	Gear
Coupling furnished by (3.2.1)	Compr. Supplier	Compr. Supplier
Mount coupling halves (3.2.2)	Compr. Supplier	Compr. Supplier
Cplg. guard adapter by (3.2.3)	Gear Supplier	Gear Supplier
Cplg. guard furnished by (3.2.3)	Compr. Supplier	Compr. Supplier
Coupling vendor (3.2.3)		
Vendor's model number (3.2.3)		
Coupling weight on shaft, kg	10,4	26,4
CG Inboard / outboard of shaft end	Outboard	Outboard
Hub drill template provided	<input type="checkbox"/>	<input type="checkbox"/>

■ SHAFT END DETAIL (2.5.4.2)		
Shaft end detail specified by:	<input checked="" type="radio"/> Purchaser <input type="radio"/> Gear vendor	
(Integral unless otherwise specified)		
Shaft end detail if 'otherwise' specified:	Pinion	Gear
Tapered / Keyless	<input type="radio"/> <input type="checkbox"/>	<input type="radio"/> <input type="checkbox"/>
Tapered / 1-Key	<input type="radio"/> <input type="checkbox"/>	<input type="radio"/> <input type="checkbox"/>
Tapered / 2-Keys	<input type="radio"/> <input type="checkbox"/>	<input type="radio"/> <input type="checkbox"/>
Cylindrical / 1-Key	<input type="radio"/> <input type="checkbox"/>	<input type="radio"/> <input type="checkbox"/>
Cylindrical / 2-Keys	<input type="radio"/> <input type="checkbox"/>	<input type="radio"/> <input type="checkbox"/>
Other <u>Flanged</u>	<input checked="" type="radio"/> <input type="checkbox"/>	<input checked="" type="radio"/> <input type="checkbox"/>
Shaft diameter	75,0	120,0 mm
(If integral flange use diameter immediately adjacent to flange)		

■ RADIAL BEARINGS		
Type	Pinion	Gear
Diameter	80 / 80	120 / 120 mm
Length	56 / 56	60 / 60 mm
Journal velocity	45,0 / 45,0	11,3 / 11,3 m/s
Loading	3,08 / 3,10	2,52 / 2,26 N/mm ²
Clearance (min-max)		
Span	340	340 mm
Power loss each bearing	6,3 / 6,3	0,7 / 0,7 kW
Oil flow each bearing	15,0 / 15,0	5,0 / 5,0 l/min

■ THRUST BEARINGS		
Location		OPP.CPLG.SIDE
Manufacturer	FLENDER	FLENDER
Type	NO	COMB.TAP.LANDS
Size		BPK LEG 4"
Area		5160 mm ²
Loading		1,35 MPa
Rating		1,50 MPa
Int. thrust load		N
Ext. thrust load	2.700	4.250 N
Power loss each	0,0	5,0 kW
Oil flow each bearing	0,0	15,0 l/min

NOTES:

■ GEAR DATA			
	Pinion	Gear	
Number of teeth	29	173	
Gear ratio	5,97		
Tangential load, *Wt* (2.2.4.2)	25.731		N
AGMA Geometry factor *J*	0,52	0,54	
Pitch diameter	111,98	668,02	mm
Outside diameter	120,30	673,50	mm
Root diameter	103,05	656,32	mm
Center groove diameter	93,00	640,00	mm
Normal pressure angle	20,00		deg
Normal diametral pitch	7,26		in ⁻¹
Helix angle	24,25		deg
Center distance	390,00		mm
Backlash min	0,28		mm
Net face width, *Fw*	130,00		mm
Pinion L/D	1,74		
Face overlap ratio	4,86		
Transverse contact ratio	1,45		
AGMA 6011 service factor	2,87		
Rating based on ANSI/AGMA 6011 with SF=1.0			
Durability Power	5404		kW
Strength Power	4652		kW
Tooth Surface Finish, Ra	0,4	0,4	µm
Tooth Generation Process	Hobbing	Hobbing	
Tooth Finishing Process	Grinding	Grinding	
Lead modification (2.2.4.6)	<input checked="" type="radio"/> Not Req'd	<input type="radio"/> Req'd	
Calculated Total Lead Mismatch			µm

■ SCUFFING DATA (2.2.6)			
Scuffing Data per ANSI/AGMA 925-A03			
Scuffing Risk (2.2.6) <=5% (Low)	Calculation Method	AGMA925	
Composite surface roughness, ox	0,57	µm	
Specific film thickness, EHL λmin	2,54	µm	
Tooth temperature, θm	80	°C	
Maximum contact temperature, θBmax	93	°C	

■ MATERIALS			
Gear casing	Steel	Oil seals	aluminium
Pinion(s)	18CrNiMo7-6		
Gear rim(s)	18CrNiMo7-6		
HS Shaft	Integral	LS Shaft	42CrMo4
Radial bearings	Babbitt	Backing	Steel
Thrust bearing(s)	Babbitt	Backing	Steel

○ SHAFT END DETAIL	
<input type="checkbox"/> Gear shaft end for coupling integral flange (2.5.4.2)	
<input type="checkbox"/> Pinion shaft end for coupling integral flange (2.5.4.2)	
<input type="checkbox"/> Other :	WITHOUT BOLTS

SPECIAL PURPOSE GEAR UNITS
API 613 FIFTH EDITION
DATA SHEET SI UNITS

Job No. 41104 Item No. B
P.O. No. _____ Date _____
Requisition No. _____
Inquiry No. _____
Revision 1 Date 06.03.2015 By HNI

1 **○ LUBRICATION REQUIREMENTS**

2 Oil system furnished by (2.8.3) _____

3 Other _____ Gear vendor _____

4 Oil visc. _____ cp @ 40°C _____ cp @ 100°C (2.8.6)

5 ISO Grade _____ Load stage (2.2.6) 7,0

6

7 **■ MESH**

8 Mesh and windage power loss 2,0 kW

9 Oil flow, mesh 9,0 l/min

10

11 **■ LUBRICATION REQUIREMENTS**

12 Min. startup oil temperature 20,0 °C

13 Normal oil inlet temperature 60,0 °C

14 Maximum oil inlet temperature 65,0 °C

15 Unit oil flow (total) 64,0 l/min

16 Unit oil pressure 2,5 bar

17 Oil visc. _____ cp @ 40°C _____ cp @ 100°C (2.8.6)

18 ISO Grade 46 Load stage (2.2.6) 7,0

19

20 **■ PIPING CONNECTIONS**

Service	No.	Size	Type
Lube oil inlet	1	1,5 in.	ANSI 150 LBS
Lube oil outlet	1	6 in.	ANSI 150 LBS
Casing drain *			
Vent	1	1,5 in.	ANSI 150 LBS
Casing purge			

27 * Casing drain is 'dead bottom' housing drain, not lube oil outlet

28 **○ MOUNTING PLATES**

29 Gear furnished with (3.3.1.1)

30 Baseplate Soleplate Subplate(s) (3.3.2.10)

31 Mounting plates(s) furnished by (3.3.1.1) _____

32 Baseplate leveling (3.3.2.3) _____

33 Baseplate with leveling pads (3.3.2.3)

34 Baseplate suitable for column mounting (3.3.2.4)

35 Vendor review of purchaser's foundation dwgs. (2.1.13)

36 Grou type (3.3.1.2.4) _____

37

38 **○ CONTRACT DATA**

39 Test data prior to shipment _____

40 Progress report (5.3.3) _____

41 Vendor signoff of inspector checklist (4.1.1.3)

42 Information retained for 20 years (4.2.1.1) (4.2.2.6.1)

43 Technical manual (5.3.5.4)

44 PAINTING (4.4.3.1) Flender standard RAL5015 (blue)

45 Painting housing interior not allowed (2.3.1.14)

46 **○ SHIPMENT**

47 Steel rotor storage container (4.4.5) Shaft covers (4.4.4)

	Contract unit	Spares
Export boxing	<input type="checkbox"/>	<input type="checkbox"/>
Domestic boxing	<input type="checkbox"/>	<input type="checkbox"/>
Outdoor storage over 6 mos.	<input type="checkbox"/>	3 years indoor <input type="checkbox"/> (4.4.3.9)

1 **○ ADDITIONAL REQUIREMENTS**

2 **○ VIBRATION DETECTORS**

3 **RADIAL** (3.4.2.1) (2.7.4.5) (2.7.4.6)

4 Manufacturer BENTLY NEVADA Total No. 8

5 X-Y probes pinion bearings Coupling end Blind end

6 X-Y probes gear bearings Coupling end Blind end

7 Other _____

8 **AXIAL** (3.4.2.1) (2.7.4.5) (2.7.4.6)

9 Manufacturer BENTLY NEVADA Total No. 2

10 Dual probes at each thrust bearing

11 Single probe any shaft without thrust bearing

12 Other _____

13 **ONE EVENT PER REVOLUTION PROBE** (2.7.4.5) (2.7.4.6)

14 Manufacturer BENTLY NEVADA Total No. 2

15 One on input shaft One on output shaft

16 Other _____

17 **ACCELEROMETER** (3.4.2.1) (2.7.4.5) (2.7.4.6)

18 Manufacturer BENTLY NEVADA No. required 2

19 Pinion coupling end Gear coupling end

20 Other _____

21 **○ TEMPERATURE DETECTORS**

22 Dial type thermometers (3.4.2.7) _____

23 Type brg. temp. sensors (3.4.2.7) (2.7.1.3) PT100

24 RTD Thermocouple / Simplex Duplex

25 Calibration Yes

26 HSAS bearings no. sensors each 2 / 2

27 Thrust number of sensing elements each face 2

28 **○ OTHER VIBRATION AND TEMPERATURE**

29 (3.4.2.5) (3.4.2.6) Other Gear vendor

30 Oscillator demodulator supplied by

31 Vibration monitor supplied by

32 Vibration shutdown delay time _____ seconds

33 Temperature monitor supplied by

34 Oscillator demodulator J-box by

35 Temp. sensor termination J-box by

36 J-box type _____ Mount _____

37 **○ MISCELLANEOUS**

38 Undamped critical analysis report (2.6.2.1)

39 w/ dampd rotr respsn analys rpt (2.6.2.4.3) (2.6.2.6)

40 Torsional analysis by (2.6.5.2) Gear vendor Other

41 Spare set of gear rotors (4.3.2.4)

42 Gear case furnished with inlet purge connection (2.4.3)

43 Orientation of oil inlet & drain conns. (2.4.6) _____

44 Filter breather location (2.3.1.12) Prov. on upper casing

45 Torsional device provisions (2.5.4.5)

46 Rotor vertical storage provisions (2.5.4.8)

47 Rotor vertical storage fixture(s) (3.6.2)

48 Vendor service rep. on site (2.1.13)

**SPECIAL PURPOSE GEAR UNITS
API 613 FIFTH EDITION
DATA SHEET SI UNITS**

Job No.	41104	Item No.	B
P.O. No.		Date	
Requisition No.			
Inquiry No.			
Revision	1	Date	06.03.2015
		By	HNI

O INSPECTIONS AND TESTS (4.1)				
	Req'd	Witness	Observe	Test Log
<input type="checkbox"/> Advance notice of witness testing required (4.1.3)				
Number calendar days _____				
Shop Inspection (4.1.1)	<input type="checkbox"/>	<input type="checkbox"/>	<input type="checkbox"/>	
Cleanliness Inspection (4.2.3.1)	<input type="checkbox"/>	<input type="checkbox"/>	<input type="checkbox"/>	
Hardness Verification (4.2.3.3)	<input checked="" type="checkbox"/>	<input type="checkbox"/>	<input type="checkbox"/>	<input checked="" type="checkbox"/>
Dismantle-reassembly (4.3.2.3.1)	<input checked="" type="checkbox"/>	<input type="checkbox"/>	<input type="checkbox"/>	<input type="checkbox"/>
Contact Check (2.5.2.2)	<input checked="" type="checkbox"/>	<input type="checkbox"/>	<input type="checkbox"/>	<input type="checkbox"/>
Contact Check Tape Lift (2.5.2.2)	<input checked="" type="checkbox"/>	<input type="checkbox"/>	<input type="checkbox"/>	<input checked="" type="checkbox"/>
Gear accuracy check (2.5.2.1)	<input checked="" type="checkbox"/>	<input type="checkbox"/>	<input type="checkbox"/>	<input type="checkbox"/>
Double helical axial stability (2.5.2.3)	<input checked="" type="checkbox"/>	<input type="checkbox"/>	<input type="checkbox"/>	<input checked="" type="checkbox"/>
Special testing integral forged gears (2.5.3.3)				
(testing per mutual agreement)	<input type="checkbox"/>	<input type="checkbox"/>	<input type="checkbox"/>	<input type="checkbox"/>
Residual unbalance check (2.6.6.2)	<input checked="" type="checkbox"/>	<input type="checkbox"/>	<input type="checkbox"/>	<input checked="" type="checkbox"/>
Mechanical Run Test (Main) (4.3.2)	<input checked="" type="checkbox"/>	<input type="checkbox"/>	<input type="checkbox"/>	<input checked="" type="checkbox"/>
Mechanical Run Test (Spare) (4.3.2.4)	<input type="checkbox"/>	<input type="checkbox"/>	<input type="checkbox"/>	<input type="checkbox"/>
Addl. Mechanical Tests (4.3.2.2.16)	<input type="checkbox"/>	<input type="checkbox"/>	<input type="checkbox"/>	<input type="checkbox"/>
Part or Full Load And Full Speed				
Test (4.3.3.1)	<input type="checkbox"/>	<input type="checkbox"/>	<input type="checkbox"/>	<input type="checkbox"/>
Full torque, reduced speed (4.3.3.2)	<input type="checkbox"/>	<input type="checkbox"/>	<input type="checkbox"/>	<input type="checkbox"/>
Full Torque Static Test (4.3.3.3)	<input type="checkbox"/>	<input type="checkbox"/>	<input type="checkbox"/>	<input type="checkbox"/>
Back-To-Back Locked Torque				
Test (4.3.3.4)	<input type="checkbox"/>	<input type="checkbox"/>	<input type="checkbox"/>	<input type="checkbox"/>
Sound Level Test (4.3.3.5)	<input checked="" type="checkbox"/>	<input type="checkbox"/>	<input type="checkbox"/>	<input checked="" type="checkbox"/>
Additional gear tooth test (4.2.2.8)	<input type="checkbox"/>	<input type="checkbox"/>	<input type="checkbox"/>	<input type="checkbox"/>
Use shop Lube System	<input checked="" type="checkbox"/>	<input type="checkbox"/>	<input type="checkbox"/>	
Use job lube system	<input type="checkbox"/>	<input type="checkbox"/>	<input type="checkbox"/>	
Use shop Vibration Probes, Etc.	<input type="checkbox"/>	<input type="checkbox"/>	<input type="checkbox"/>	
Use job Vibration Probes, Etc.	<input checked="" type="checkbox"/>	<input type="checkbox"/>	<input type="checkbox"/>	
Final Assembly, Maintenance &				
Running Clearance (4.2.1.1.e)	<input checked="" type="checkbox"/>	<input type="checkbox"/>	<input type="checkbox"/>	<input checked="" type="checkbox"/>
Oil System Cleanliness (4.2.3.2)	<input type="checkbox"/>	<input type="checkbox"/>	<input type="checkbox"/>	
Oil System-Casing Joint				
Tightness (4.3.2.1.4)	<input type="checkbox"/>	<input type="checkbox"/>	<input type="checkbox"/>	
Warning And Protection				
Devices (4.3.2.1.5)	<input type="checkbox"/>	<input type="checkbox"/>	<input type="checkbox"/>	
Seismic Vibration Data (4.3.2.2.3)	<input type="checkbox"/>	<input type="checkbox"/>	<input type="checkbox"/>	<input type="checkbox"/>
Vibration, Phase Plots (4.3.2.2.12)	<input checked="" type="checkbox"/>	<input type="checkbox"/>	<input type="checkbox"/>	<input checked="" type="checkbox"/>
Oil Inlet Range test (4.3.2.2.13)	<input type="checkbox"/>	<input type="checkbox"/>	<input type="checkbox"/>	<input type="checkbox"/>
Tape recorded Vibration Data	<input checked="" type="checkbox"/>	<input type="checkbox"/>	<input type="checkbox"/>	<input checked="" type="checkbox"/>
(4.3.2.2.14) (4.3.2.2.15)	<input type="checkbox"/>	Purchaser copy		
NON-DESTRUCTIVE TESTING (4.2.1.2) (4.2.2.1)				
	Surface	Sub surface		Log
<input type="checkbox"/> Casing	<input type="checkbox"/>	<input type="checkbox"/>		<input type="checkbox"/>
<input checked="" type="checkbox"/> Rot. Elemen.	<input checked="" type="checkbox"/>	<input checked="" type="checkbox"/>		<input checked="" type="checkbox"/>
<input checked="" type="checkbox"/> Bearings	<input checked="" type="checkbox"/>	<input checked="" type="checkbox"/>		<input checked="" type="checkbox"/>
<input type="checkbox"/> Other :	<input type="checkbox"/>	<input type="checkbox"/>		<input type="checkbox"/>
(Specify)				

NOTES :

During start-up, gears can exhibit a transient spike reading of vibration levels that will exceed shutdown settings. Therefore a trip multiplier is recommended in the control system.

Mechanical running test duration 4 hours including

- Shaft vibration record using job vibration probes if ordered
- Bearings temperature records
- Casing vibration measurement
- Sound level pressure measurement
- Power losses measurement at oil outlet
- Performed with oil ISO VG 32

Oil flow requirement and power losses are calculated values only, add normal safety margins for sizing heat exchangers.

PRELIMINARY MASS ELASTIC DATA

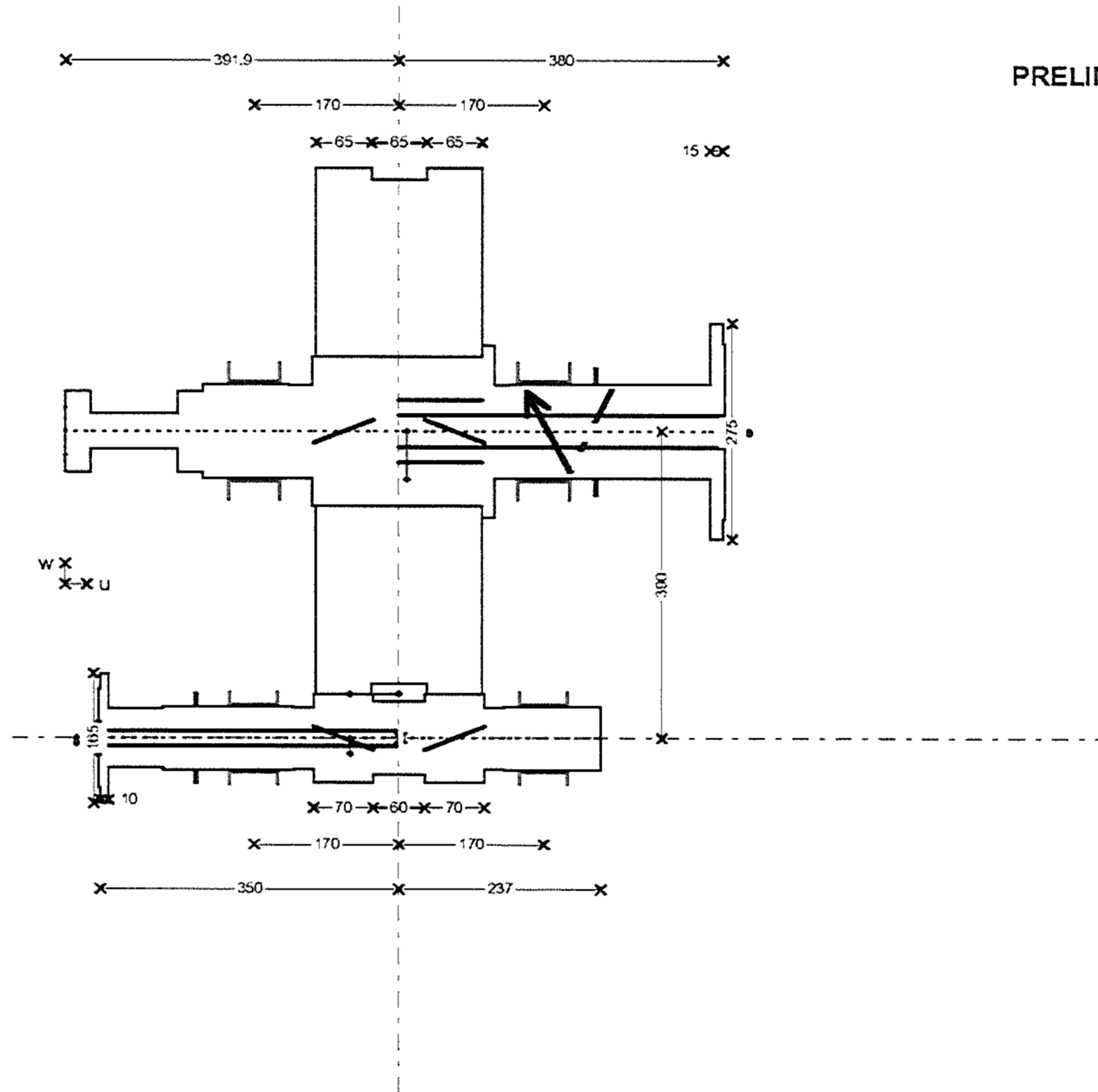

Customer : Siemens AG Duisburg
 Destination : Khursaniyah Al Fadhli
 Purchaser order :
 F-G job number : D 41104B1 OL:
 Type and serial N° : TX40/5C

Power rating : 1620 kW
 Service factor : $AP1613/03 \geq 1,4$
 Input speed : 1800 rpm
 Output speed : 10737,9 rpm
 Speed ratio : 5,96

Weight HSS : 30,5 kg
 Weight pos. from teeth middle HSS : -57,5 mm
 Inertia HSS : 0,038 Kg.m²
 Stiffness HSS : 1,11 MNm/rd
 Bearing type 1 : Tilting pads 80 x 56
 Bearing type 2 : Tilting pads 80 x 56
 Add. weight on brg. side 1 : 10,4 kg

Weight LSS : 574,3 kg
 Weight pos. from teeth middle LSS : 9 mm
 Inertia LSS : 28,526 Kg.m²
 Stiffness LSS : 6,5 MNm/rd
 Bearing type 4 : Cylindrical 120 x 60
 Bearing type 3 : Cylindrical 120 x 60
 Add. weight on brg. side 4 : 26,4 kg

→
 Positive direction of external
 APPAREIL.xls _ Edition du :06.03.2015

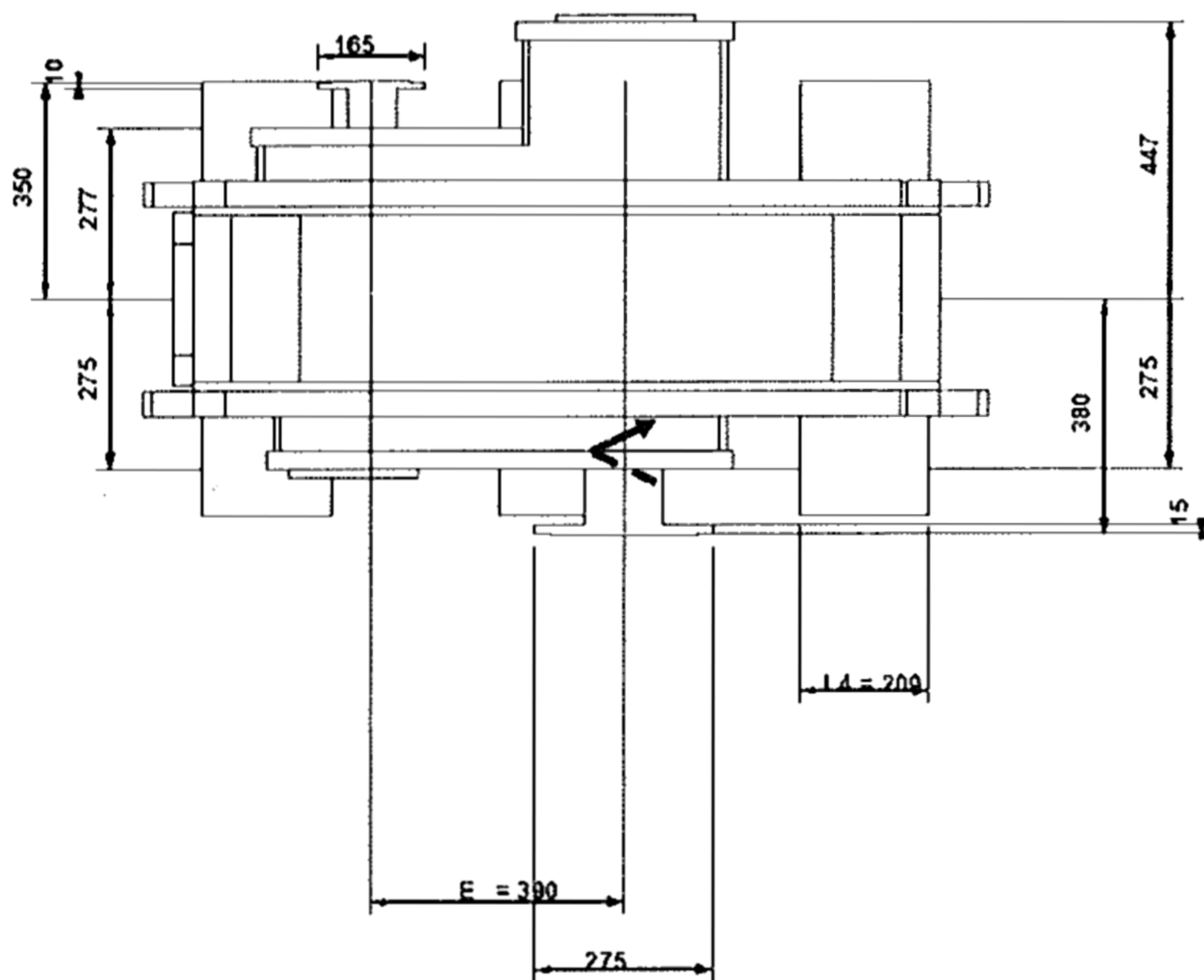
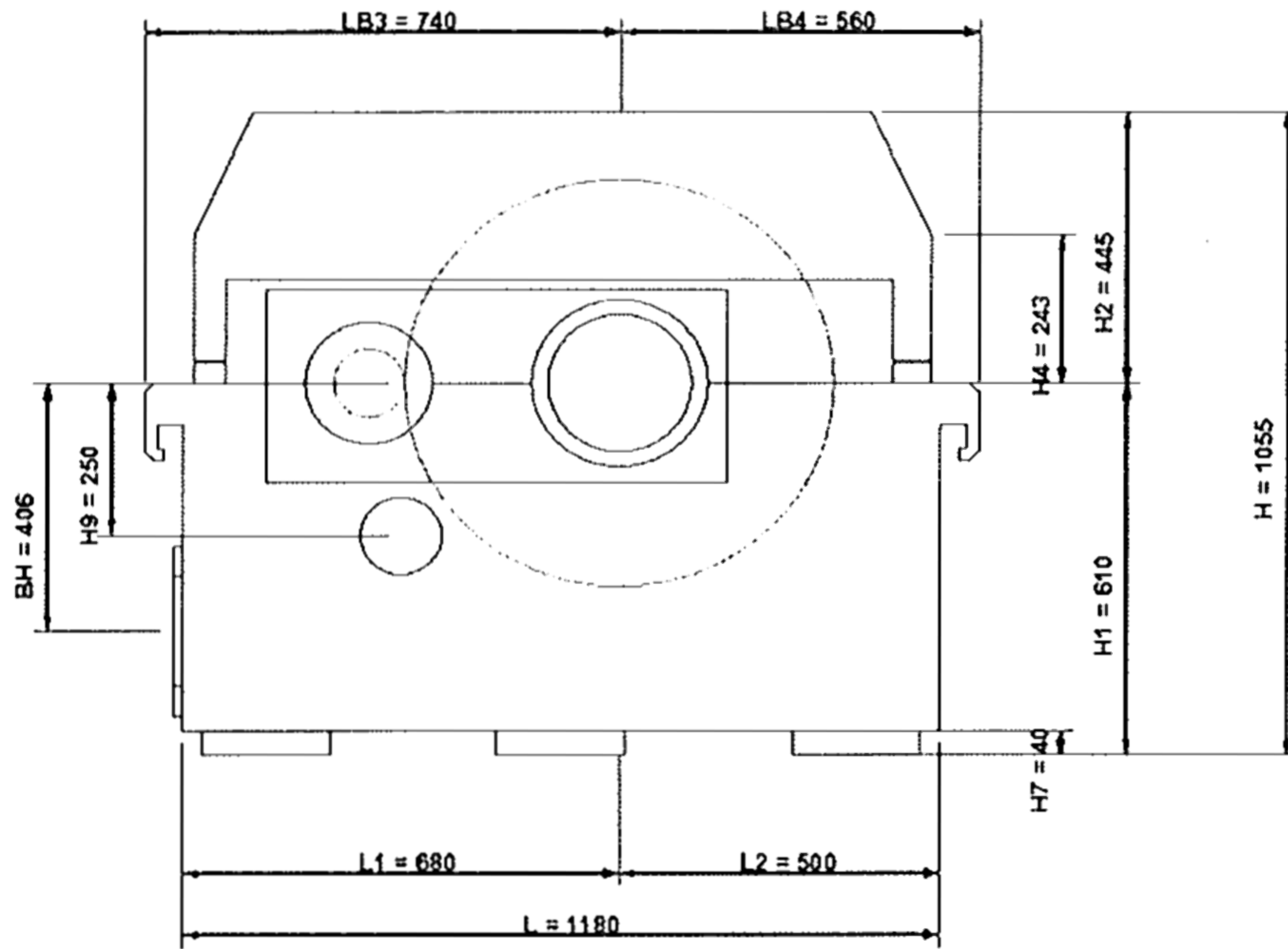

ADDITIONAL TECHNICAL DATASHEET		Job No. <u>41104</u> Item No. <u>B</u>																																		
		P.O. No. _____ Date _____																																		
		Requisition No. _____																																		
		Inquiry No. _____																																		
		Revision <u>1</u> Date <u>06.03.2015</u> By <u>HNI</u>																																		
<input checked="" type="checkbox"/> ADDITIONAL GEAR DATA		<input type="checkbox"/> TURNING GEAR (Dimensioning is preliminary !)																																		
<i>Efficiency</i>		<i>Calculation results</i>																																		
<table border="1" style="width:100%; border-collapse: collapse;"> <thead> <tr> <th>Percent of rated power</th> <th>Efficiency</th> </tr> </thead> <tbody> <tr> <td>100%</td> <td style="text-align: center;">98,70</td> </tr> <tr> <td>75%</td> <td style="text-align: center;">98,66</td> </tr> <tr> <td>50%</td> <td style="text-align: center;">98,38</td> </tr> <tr> <td>25%</td> <td style="text-align: center;">97,42</td> </tr> <tr> <td>10%</td> <td style="text-align: center;">87,68</td> </tr> </tbody> </table>		Percent of rated power	Efficiency	100%	98,70	75%	98,66	50%	98,38	25%	97,42	10%	87,68	Required turning speed _____ rpm Actual turning speed _____ rpm Required breakaway torque _____ Nm Actual breakaway torque _____ Nm Actual maximum torque _____ Nm Actual acceleration time _____ s																						
Percent of rated power	Efficiency																																			
100%	98,70																																			
75%	98,66																																			
50%	98,38																																			
25%	97,42																																			
10%	87,68																																			
<i>Losses</i>		<i>Motor</i>																																		
Power loss at no load _____ kW Heat rejection _____ kcal/h		Supplier _____ Power _____ kW Voltage _____ V Frequency _____ Hz Speed _____ rpm Electric standard _____																																		
<input type="checkbox"/> PUMP DETAILS (Dimensioning is preliminary !)		<i>Turning gear</i>																																		
Design : _____ Speed : _____ rpm Oil flow : _____ l/min Oil pressure : _____ bar NPSH : _____ m Safety valve : _____ Driving method : _____ Material : _____ Flanges : _____ Testing : _____ Furniture of ATEX certificate : _____		Type _____ Ratio _____																																		
		<i>Clutch</i>																																		
		Type _____ Max allowable torque _____ Nm																																		
		<i>Miscellaneous</i>																																		
		Starting device _____ Switch details _____																																		
<input checked="" type="checkbox"/> INSTRUMENTATION PACKAGE																																				
<i>Thermometer</i>		<i>Thermoelements</i>																																		
<table border="1" style="width:100%; border-collapse: collapse;"> <thead> <tr> <th></th> <th>Bearing</th> <th>Thrust bearing</th> <th>Oil inlet/outlet</th> </tr> </thead> <tbody> <tr> <td>Qty</td> <td></td> <td></td> <td></td> </tr> <tr> <td>Type</td> <td></td> <td></td> <td></td> </tr> </tbody> </table>			Bearing	Thrust bearing	Oil inlet/outlet	Qty				Type				<table border="1" style="width:100%; border-collapse: collapse;"> <thead> <tr> <th></th> <th>Bearing</th> <th>Thrust bearing</th> <th>Oil inlet/outlet</th> </tr> </thead> <tbody> <tr> <td>Type</td> <td>DUPLEX 2x3F</td> <td>DUPLEX 2x3F</td> <td></td> </tr> <tr> <td>Classification</td> <td>IEC60751</td> <td>IEC60751</td> <td></td> </tr> <tr> <td>Removable from the outside</td> <td>NO</td> <td>NO</td> <td></td> </tr> <tr> <td>ATEX</td> <td>ATEX Eexia</td> <td>ATEX Eexia</td> <td></td> </tr> </tbody> </table>			Bearing	Thrust bearing	Oil inlet/outlet	Type	DUPLEX 2x3F	DUPLEX 2x3F		Classification	IEC60751	IEC60751		Removable from the outside	NO	NO		ATEX	ATEX Eexia	ATEX Eexia		
	Bearing	Thrust bearing	Oil inlet/outlet																																	
Qty																																				
Type																																				
	Bearing	Thrust bearing	Oil inlet/outlet																																	
Type	DUPLEX 2x3F	DUPLEX 2x3F																																		
Classification	IEC60751	IEC60751																																		
Removable from the outside	NO	NO																																		
ATEX	ATEX Eexia	ATEX Eexia																																		
<i>Shaft vibrations</i>																																				
<table border="1" style="width:100%; border-collapse: collapse;"> <thead> <tr> <th></th> <th>Radial</th> <th>Axial</th> <th>Keyphasor</th> <th>Accelerometer</th> </tr> </thead> <tbody> <tr> <td>Type</td> <td>B.N. 3300 XL 8mm Sys. 9M</td> <td>HS LS</td> <td>No</td> <td>B.N. 3300 XL 8mm Sys. 9M</td> </tr> <tr> <td>Probe</td> <td>Yes</td> <td>HS LS</td> <td>No Yes</td> <td>Yes</td> </tr> <tr> <td>Proximitior</td> <td>Yes</td> <td>HS LS</td> <td>No Yes</td> <td rowspan="4" style="background-color: #cccccc;"></td> </tr> <tr> <td>Probe holder</td> <td>Yes</td> <td>HS LS</td> <td>No Yes</td> </tr> <tr> <td>Connection head</td> <td>Yes</td> <td>HS LS</td> <td>No Yes</td> </tr> <tr> <td>mounting kit</td> <td></td> <td></td> <td>Yes</td> <td>Yes</td> </tr> </tbody> </table>					Radial	Axial	Keyphasor	Accelerometer	Type	B.N. 3300 XL 8mm Sys. 9M	HS LS	No	B.N. 3300 XL 8mm Sys. 9M	Probe	Yes	HS LS	No Yes	Yes	Proximitior	Yes	HS LS	No Yes		Probe holder	Yes	HS LS	No Yes	Connection head	Yes	HS LS	No Yes	mounting kit			Yes	Yes
	Radial	Axial	Keyphasor	Accelerometer																																
Type	B.N. 3300 XL 8mm Sys. 9M	HS LS	No	B.N. 3300 XL 8mm Sys. 9M																																
Probe	Yes	HS LS	No Yes	Yes																																
Proximitior	Yes	HS LS	No Yes																																	
Probe holder	Yes	HS LS	No Yes																																	
Connection head	Yes	HS LS	No Yes																																	
mounting kit			Yes		Yes																															
<i>Junction box(es)</i>		<i>Miscellaneous</i>																																		
Qty _____ Manufacturer _____ Material _____ ATEX _____		Identification <input checked="" type="checkbox"/> wire <input checked="" type="checkbox"/> conduit <input type="checkbox"/> junction box Conduit type _____ Transmitter type _____ Qty _____ Terminal block type _____ Qty _____																																		

FLENDER GRAFFENSTADEN

FLENDER-GRAFFENSTADEN S.A., FRANCE
BP 84, F-67402 ILLKIRCH-CEDEX
1, rue du Vieux Moulin
F-67400 ILLKIRCH-GRAFFENSTADEN

Commercial Conditions

- Prices are quoted FCA Illkirch-Graffenstaden following Incoterms 2010 including packing cat 1A of SEI, 1999 issue, ind. 2.
- Progress payments : 100% at delivery.
- This quotation is subjected to the Flender Graffenstaden Standard Terms and Conditions of Sales and valid for acceptance until the 15th of July 2015.
- Where approval of drawings is required, approval must be in line with the document schedule.
- Warranty period is 18 months of operation or 24 months after delivery whichever occurs first. We recommend the supervision of our engineer for the commissioning.
- Flender-Graffenstaden SAS shall not be obligated to fulfill this agreement if such fulfillment is prevented by any impediments arising out of national or international foreign trade or customs requirements or any embargoes or other sanctions.

Applicable documents for the quotation (available on demands)

Documents schedule,
Quality plan
Painting standard,
Standard Terms and Conditions of Sales

We thank you for the opportunity of quoting and look forward to the pleasure of serving you.

Very truly yours,

N. HOST
(Project Engineer)

Y. FRIEDMANN
(Sales Manager)

Generated with CAMEC V 4.9.5 26 Feb 2014

**** "This quotation is subject to confidentiality. Information thereof may not be shared with or forwarded to any third parties!"**