

Delivery Specification

Project name:

Project number:

Reviewer:

Date: 16.10.2020

Version: V3.1



Copyright © ZF Friedrichshafen AG

This document is protected by copyright.

Complete or partial reproduction or distribution of this document is not permitted without the approval of ZF Friedrichshafen AG.

Infringements lead to civil and criminal prosecution.

This document is a translation of the German original.

1 General Part

1.1 Scope of application

The "ZF Technical Delivery Specifications for Machines and Machine Systems" (hereinafter called "Technical Delivery Specifications") described here is valid for all ZF plants worldwide.

The term "Contractor" refers to the supplier of the machine/machine system, while the term "Customer" refers to ZF Friedrichshafen AG or the ZF location issuing the purchasing order.

1.2 General Requirements

1.2.1 Order of precedence

The relationship and order of precedence of these Technical Delivery Specifications regarding other agreements between Customer and Contractor are governed elsewhere, usually in the framework contract or in the minutes of negotiation.

The Contractor must notify the Customer about any contradictory statements within these Technical Delivery Specifications and cooperate on a solution.

1.2.2 Quotation

List the costs of any workpiece-specific scope separately.

The quotation must include information on all necessary media, connected loads, consumption values, dimensions and requirements for the installation site of the machine/machine systems.

Submit a filled-out operating sheet (job card) for space and installation planning (based on Annex 3: Operating Sheet for Space and Installation Planning) when you submit your quotation.

Furthermore, reference is expressly made to the compliance (e.g. Nondisclosure) with the latest "ZF Terms and Conditions of Purchase for Machines and Machine Systems".

1.2.3 Project schedule

When confirming the purchase order, the Contractor must send the Customer a detailed project schedule listing the Contractor's plans for completing the order. The Contractor must automatically update this project schedule at least every four weeks and then submit it to the Customer.

The Contractor must notify the Customer immediately about any changes to the project schedule that threaten to delay or compromise the completion of the order. Such changes require a release.

1.2.4 Order processing/deviations

If the Contractor has gained knowledge or realized - thanks to his expertise - that he is unable to provide contractually agreed services, or can only provide limited suitability for the intended purpose, he is obliged to notify the Customer of this immediately. If this requires deviations from the Technical Delivery Specifications, they must be requested in writing, giving technical reasons, and they must be approved by the Customer (they must be entered in the standard form, see Appendix 06). They only apply to the specific order.

1.2.5 Overall machine function

If the existing machines/machine systems are expanded and/or modified, the Contractor shall also be responsible for the overall function of the machines/machine systems affected by the expansion and/or modification, provided that no other agreement has been expressly made to the contrary.

Any modifications of the machine/machine system performed while work is being done on the order shall require the written consent of the Customer.

1.2.6 Equipment

The same equipment must be used within each machine/machine system. In other words, components and/or assemblies with the same function from different manufacturers may not be used.

Only components, assemblies, devices, and process materials may be used that appear on the Customer's approved list. They must be in their original condition and without any modifications whatsoever when installed. Unacceptable actions include the drilling of fastening holes, removing housing parts, modifying shaft ends and altering circuits.

The manufacturers' setup and installation instructions for devices and systems are binding.

The Customer must be informed of any work equipment requiring inspection and facilities requiring monitoring (components, assemblies and devices). They must be included in Annex 2 Overview list. An agreement must be reached with the Customer on inspection periods (e.g. inspecting pressure vessels).

1.2.7 Subcontractors

The Contractor must ensure that all subcontractors also comply with the Technical Delivery Specifications. The Contractor is responsible for arranging and coordinating this compliance.

1.2.8 Documentation of the Contractor

In the case of constructions and workpiece-dependent equipment commissioned by the Customer, the complete documentation (e.g. construction drawings, assembly and individual part drawings with parts lists of the machine or machine system, fixtures and tools) shall become the property of the Customer in electronic and copy-capable versions, and be made available without restrictions.

Machine parts list (Machine BoM) and ABC risk analysis for spare and wear parts:

- The ABC risk analysis to determine critical spare and wear parts for each machine type is created by the Contractor with the help of the ZF template (Excel) (www.zf.com - ZF Supplier Board - Terms and Conditions of Purchase - Technical Delivery Specifications - Annex 4). The analysis shall be performed according to the ZF standard template. A temporary version has to be made available to ZF 3 months after design release, the final version at the latest before the delivery approval.
- The complete machine parts list including the critical spare and wear parts must be provided in Excel (preferably in the same format as the ABC risk analysis) and sent by e-mail to the ZF inbox machine-bom@zf.com as well as to the ZF technical project manager with the subject "[ZF ProjectID]_[ProjectName]_[ZF location]_[your company name]".
- The lists under a) and b) are part of the machine documentation and therefore part of the machine acceptance (completeness, up-to-dateness).

1.2.9 Customer's drawings

The Customer must safely destroy all received drawings, including copies and other duplications, within a reasonable amount of time.

Furthermore, reference is expressly made to the terms and conditions (e.g. Nondisclosure) of the current version of the "ZF Terms and Conditions of Purchase for Machines and Machine Systems".

1.2.10 Nondisclosure

Exhibits of the machines/machine systems intended for the Customer and the publication of videos, photos, drawings, technology data, etc., shall require the written consent of the Customer.

Furthermore, reference is expressly made to the terms and conditions contained in the "ZF Terms and Conditions of Purchase for Machines and Machine Systems".

1.3 Normative references

Although the Technical Delivery Specifications may not indicate those aspects in detail, the Contractor is fully liable for ensuring that all requirements relating to the performance rendered by the Contractor – beyond the scope of the aforementioned Technical Delivery Specifications – that are derived from regulations (e.g. EU directives, regulations and other applicable legislation) as well as standards and generally accepted rules of technology are adhered to (referred to in the following as “directives, standards and rules”).

To the extent that the present Technical Delivery Specifications refer to directives, standards, and rules of technology, the Contractor has to independently verify whether these are relevant for the service rendered and whether there are other directives, standards and rules that the Contractor must observe. In cases of doubt, the Contractor must contact the Customer immediately.

Moreover, the Contractor will immediately inform the Customer if – thanks to his expertise in the matter concerned – the Contractor has gained knowledge or realized that the performance/service to be rendered for the Customer can only be used to a limited degree or not at all for the intended purpose.

General Part

1.3.1 Other applicable documents

Currently valid ZF Terms and Conditions of Purchase for Machines and Machine Systems (see www.zf.com)

Number	Description
DIN EN ISO 12100	Safety of machinery - Basic concepts, general principles for design
VDI 3423	Technical availability of machines and production lines - Terms, definitions, determination of time periods and calculation

Table 1

1.3.1.1 Other applicable documents (additional for Europe)

Number	Description
DIN EN 60204-1	Safety of machinery – Electrical equipment of machines – Part 1: General requirements

Table 2

1.3.1.2 Other applicable documents (additional for Germany)

Number	Description
VDA-LVE	German Association of the Automotive Industry - Delivery specifications for the electrical equipment of machines, machine systems and equipment
VDI 2856	Standardized specification for inquiries and offers on machine tools
DIN 4150 Part 2	Vibrations in buildings - Part 2: Effects on persons in buildings
§ 19 WHG	Federal Water Act
German occupational exposure limit (AGW) acc. to GefStoffV	Occupational exposure limit in accordance with the Hazardous Substances Ordinance
TA Luft	Technical Instructions on Air Quality Control
TA Lärm	Technical Instructions on Noise Protection

Table 3

1.4 Definitions

The definitions listed constitute supplementary information to DIN EN 60204-1, VDA-LVE, DIN EN ISO 12100 and VDI 2856.

1.4.1 Error list

The error list describes the sources, types and possible combinations of errors.

1.4.2 Operating modes

The Contractor must implement a secure automatic and initial setup operation in the machine/machine system.

1.4.2.1 Automatic

During automatic operation, the production process of the machine/machine system runs automatically, regardless of whether the loading takes place manually or with automation.

The following sub-modes are possible:

- "Semi-automatic (automatic without loading automation):
The machine/machine system runs with manual feeding and/or removal of parts."
- "Fully automatic (automatic with loading automation):
The machine/machine system runs with automatic feeding and/or removal of parts."
- "Home position return:
When this function is selected, the machine/machine system automatically moves to a defined position (home position)."

1.4.2.2 Setup

In setup operation, every function must be individually selectable in compliance with the safety rules (e.g. reduced speed and/or power, enabling button, two-hand operation, safety light grid). The setup operation shall be coordinated with the Customer.

1.4.3 Substeps within the operating modes

1.4.3.1 Manual mode

Each individually defined program step is executed with a start signal. All safety devices are active.

1.4.3.2 Running empty

All parts within the machine/machine system or magazine are processed fully automatically when the corresponding selection has been made. The feed inlet for processing additional parts will be blocked.

1.4.3.3 Stopping at cycle end

When processing of the part is finished, the machine/machine system stops, e. g. in home position.

1.5 Process capability / Availability

1.5.1 Short-term process capability (machine capability)

1.5.1.1 General requirements

The machine/machine systems must be capable of short-term process capability (machine capability) with the respectively required properties for workpieces listed in the requirement specification in accordance

General Part

with the applicable inspection and/or procedural instructions valid for the respective division with a cmk value ≥ 1.67 or in accordance with other agreements.

The short-term process capability (machine capability) shall be guaranteed by the Contractor until the end of the period of limitation for defects.

1.5.1.2 Verification

The Contractor must prove the short-term process capability (machine capability) for the first time during the test run at the Contractor's plant. This is an essential part of the final acceptance criteria and is a requirement for final acceptance to be granted and the period of limitation for defects to end. In this case, the Contractor must satisfy the machine or system-specific requirements, respectively.

1.5.1.3 Defects

If the Contractor is not able to verify short-term process capability (machine capability) during the test run at the Contractor's or during the acceptance process, the previously specified provisions apply.

If the short-term process capability (machine capability) of the machine/machine system fails during the limitation period for defects and the Customer is not to blame, the Contractor must correct this defect within a period determined by the Customer.

If the short-term process capability is not achieved after a reasonable period, this shall be considered abnormal. To address this issue and to solve any outstanding problems, negotiations shall be taken up by both partners. The same also applies to serious damage during the period of limitation for defects.

1.5.1.4 Extension of the warranty period

If the short-term process capability (machine capability) is not realized during the last month of the limitation period for defects and the Customer is not to blame, then the limitation period for defects shall be extended automatically by one month, respectively, until short-term process capability (machine capability) is achieved.

1.5.1.5 Measuring equipment capability

The measuring and test equipment must be capable of measuring/testing the workpieces with a cgk > 1.0 with the required properties listed in the requirement specification or the accuracy required by the Customer vis-à-vis standard parts.

Moreover, the previously agreed provisions shall apply.

1.5.2 Long-term process capability

1.5.2.1 General requirements

The machine/machine systems must be capable of long-term process capability with the respective required properties for workpieces listed in the requirement specification in accordance with the applicable inspection and/or procedural instructions valid for the respective division with a cpk value ≥ 1.33 or in accordance with other agreements.

The long-term process capability is to be guaranteed by the Contractor until the end of the period of limitation for defects.

1.5.2.2 Verification

The long-term process capability is an essential part of the final acceptance criteria and shall be determined by the Customer for the first time following the ready-for-operation delivery of the machine/machine system, but no later than 6 months after ready-for-operation delivery. In this case, the Contractor must satisfy the machine or system-specific requirements.

1.5.2.3 Defects

If the Contractor cannot provide verification for long-term process capability during the test run at the Customer, the acceptance implementation process is delayed until the time of the successful defect correction; the provisions for defects specified in Chapter (*refer to section Defects, page 45*) apply respectively.

If the long-term capability of the machine/machine system fails during the limitation period for defects and the Customer is not to blame, the Contractor must correct this defect within a period determined by the Customer.

If the long-term process capability is not achieved after a reasonable period, this shall be considered abnormal. To address this issue and to solve any outstanding problems, negotiations shall be taken up by both partners. The same also applies to serious damage during the period of limitation for defects.

Furthermore, reference is expressly made to the "ZF Terms and Conditions of Purchase for Machines and Machine Systems".

1.5.2.4 Extension of the period of limitation for defects

If the long-term process capability is not realized during the last month of the period of limitation for defects and the Customer is not to blame, then the limitation period for defects shall be extended automatically by one month, respectively, until long-term process capability is achieved.

1.5.3 Technical availability

1.5.3.1 General requirements

The machine/machine system must provide the technical availability ($\geq 98\%$) required by the Customer.

Moreover, the machine/machine system shall provide a uniformly high degree of availability over its entire service life.

1.5.3.2 Verification

The technical availability and the downtime for the machine/machine system are determined using VDI 3423 as a basis. The technical availability and downtime are calculated in each case as the average of the last three months at the time of consideration. The evaluation itself shall take place each month.

1.5.3.3 Defects

If the technical availability of the machine/machine system fails during the limitation period for defects and the Customer is not to blame, the Contractor must correct this defect within a period determined by the Customer.

If technical availability is not achieved after a reasonable period, this shall be considered abnormal. To address this issue and to solve any outstanding problems, negotiations shall be taken up by both partners. The same also applies for serious damage during the period of limitation for defects.

Furthermore, reference is expressly made to the "ZF Terms and Conditions of Purchase for Machines and Machine Systems".

1.6 Requirement of the Operators/Maintenance

1.6.1 Instruction and training of operating and maintenance staff

1.6.1.1 General requirements

The Contractor is to document the successful instruction and training of the Customer's operating and maintenance staff (scope, name of participants and signatures of instructor and participants). Multiple-shift operation of the machine/machine system is to be taken into account and performed for the respective shifts.

If the Customer's operating and maintenance staff are insufficiently trained or are not trained on time due to the Contractor's negligence, the Contractor must ensure the availability of the machine/machine system with his own personnel and at no cost to the Customer until the necessary training level is achieved.

1.6.1.2 Instruction

Instruction/training of the Customer's operating and maintenance staff is included in the scope of delivery for the machine/machine system. The Contractor must coordinate the location, date and duration of instruction/training with the Customer.

Instruction/training for the operating and maintenance staff is to be performed separately.

The following mandatory topics must be dealt with comprehensively during instruction/training:

- Overall machine/machine system function
- Automation concept - Hardware setup - Installation concept
- Operating and message concept (e.g. status messages and error reports)
- Software structure
- Modules for units (unit module, connecting module)
- Setup of data coupling (e.g. data exchange between machine control unit and coordinating control)
- Explanation of the option for changing the parameters and texts (incl. the execution of practical examples)
- Troubleshooting and error tracking using documentation, e.g. with the help of a programming device
- Safety and protective equipment - Remaining risks of the machine/machine system.

1.6.1.3 Training

The Contractor is to submit a quotation coordinated with the Customer concerning the scope and cost of sufficient system training in hardware and software (e.g. for function and overview of the machine/machine system, CNC control, PLC control, motors, measuring systems and/or measuring equipment, hardware and software of the machine/machine system).

1.6.1.4 Instruction and training material

For the introduction or system training, materials from the documentation are to be prepared and made available to each introduction and training participant (such as programmed instruction, operating instructions, device descriptions, programming instructions, special course material, diagnostic assistance, startup manual, safety instructions).

1.6.2 Provision of spare parts

The Contractor must ensure that the Customer can obtain spare parts for built-in components in the machine/machine system within 24 hours on weekdays. This also applies to any subcontractors.

The Contractor must make spare parts available to the Customer within 24 hours on weekdays for at least 15 years, starting with the date of acceptance (start of the term of limitation for defects) for the delivery item. Thereafter, the Contractor must at least keep drawings available so that the Customer can manufacture the item in-house. This also applies to wear parts.

If the Contractor, regardless of culpability, is not able to or for some reason might not be able to meet the obligations of Sections 1 and 2, either in the short or long term, he must inform the Customer immediately and collaborate on the appropriate corrective measures.

If special parts are used, the Contractor shall allow the Customer to order spare parts directly from the manufacturer.

1.6.2.1 ZF ABC risk analysis for spare parts and wear parts lists

For all machines/machine systems, a risk analysis for spare parts and wear parts shall be conducted according to the provisions of ZF Friedrichshafen AG (Annex 4).

This means that all spare and wear parts installed in the machine/machine system shall be listed including their standard designation and sources of supply, and critical parts shall be identified based on the assessment of predefined criteria (sequence of failure, frequency of failure and detection).

The filled-in template shall be part of the documentation.

1.6.3 Efficient maintenance and machine management (TPM)

1.6.3.1 Service and maintenance concept

In the tender phase, the Contractor shall cooperate with the Customer to develop a service and maintenance concept.

1.6.3.2 General requirements

The maintenance cost of the machine/machine system is to be kept as low as possible. The Contractor must indicate this in the quotation both in terms of time and money, assuming a runtime of 5 000 h. This amount is a criterion for the evaluation of the machine/machine system and may become part of the contract.

Non-productive and dead times for the machine/machine system must be kept to a minimum. This applies especially to setup processes. The Contractor must explain in writing which measures have been taken or planned, so that the machine/machine system can be quickly and safely reset within the setup time required by the Customer. Setup or resetting should not require any tools if at all possible.

1.6.3.3 Contents

1.6.3.3.1 Simple cleaning (TPM Stage 1)

The machine/machine system operators and/or the production personnel must be able to clean the machine/machine system easily.

An appropriate cleaning schedule must be provided for the machine/machine system operator.

Facings and covers shall preferably have smooth surfaces. Dirt-collecting corners, chip-trapping cavities and horizontal surfaces (interior angle < 90°) are to be avoided.

If dirt cannot be prevented, suitable containers must be provided to collect it. These must be easy to empty without having to shut down the machine/machine system.

The ingress/distribution of soiling and particles is to be avoided.

When using fluids (cooling lubricant, hydraulic fluid, etc.), the seal integrity of all systems is especially important, in other words, the machine/machine system must not leak.

1.6.3.3.2 Implement known improvements/optimizations (TPM Stage 2)

In a joint meeting before design release is given, the weaknesses identified by the Customer and Contractor must be presented and solutions must be developed to prevent and/or eliminate them. All optimizations and improvements must be scheduled and implemented for the machine/machine system to be built. The Contractor is responsible for coordinating this.

If machines/machine systems that are identical or similar in construction are to be delivered, then the updated standard as agreed between the Contractor and the Customer must be complied with. Moreover, all improvements identified by the Customer and Contractor must be taken into account and implemented in the machine/machine system to be built as agreed with the Customer.

If advances relating to possible improvements occur while the machine/machine system is being built, then these improvements must be taken into account and implemented — after consultation with the Customer.

1.6.3.3.3 Low inspection and maintenance costs (TPM Stage 3 and 4)

The machine/machine system must be low-maintenance, i.e.: inspection intervals > 1 week, servicing intervals > 1 year. Any necessary inspection and maintenance points (e.g. oil level gage glasses, pressure gages, grease nipples, etc.) must be easily accessible and visible on the machine/machine system. The proper fill level or setting value must be marked (min/max) or color-coded in each case.

It must be possible to perform necessary inspections during machine/machine system operation.

All components of the machine/machine system that are not wear-free must:

- - be equipped with a central lube system or permanent lubrication,
- - be capable of being re-adjusted or re-tightened
- - be quick to replace without special tools.

The necessary maintenance and inspection work and their cycles must be clearly described in a maintenance schedule for each machine/machine system.

1.6.3.3.4 Ease and speed of repairs (TPM Stage 5 and higher)

The diagnosis must be clear and comprehensive enough that the operator can independently detect and correct, if necessary, any malfunctions in the machine/machine system.

It should be possible for the machine/machine system operator to make simple repairs. This means that all components must be accessible and that sufficient installation and removal space is to be incorporated. To this end, all protective equipment must continuously remain in operation.

It must be as easy as possible to replace components and assemblies. Plugs are to be used in the connections.

If maintenance must be performed on machines, there must be safe platforms and/or safety systems.

Components and assemblies are to be connected and protected in such a way that they are not damaged by being stepped on, falling parts, chips and machine/machine system malfunction.

If identical machines/machine systems are to be delivered, all modified components and assemblies must be compatible. Components and control elements (sensors, actuators, plug-in connectors, wires, etc.) must be marked on the machine/machine system clearly and permanently. The function must be indicated in comprehensible plain text.

1.7 Requirements for energy efficiency, environmental protection, occupational, fire and machinery safety

The Contractor guarantees and declares on a binding basis that the machinery/assemblies of machinery meet(s) all necessary national specifications, for example, CE conformity process (Europe, if applicable: China) or OHSAS 18001 (USA) or China CCC Compulsory Certification (China), and corresponds, among other things, to the respective state-of-the-art technology and technical safety regulations.

The Contractor guarantees the ultimate suitability and configuration of the completed/partly completed machine(s)/machine system(s) for the intended use.

The Contractor must minimize residual risks by way of suitable safety precautions.

The Contractor must describe any remaining residual risks to ZF in detail so that they can be assessed by Occupational Safety and Health.

The Contractor must be ready to explain any safety-relevant functions and characteristics if required.

The Contractor must detail the key safety-related regulations and standards with which the machine has been declared compliant (e.g. CE certificate of conformity) or has been certified as being compliant by third parties.

1.7.1 Scope of application and general requirements regarding the environment...

1.7.1.1 Scope of application

The technical instructions described here apply specifically to safety of machinery, environmental and fire safety requirements for the machine/machine system. They supplement the instructions listed in Chapter I "General Part" and all other Technical Equipment Instructions of the Technical Delivery Specifications of ZF Friedrichshafen AG and alongside these, are valid for all ZF plants.

1.7.1.2 General Requirements

If information and warning notices must be attached to the machine/machine system due to the existence of residual risks, EN ISO 7010 shall be applied (Graphical symbols – Safety colors and safety signs – Registered safety signs (ISO 7010:2011)).

1.7.1.3 Disposal of machines/machine systems

In the technical documentation, the Contractor must describe how machines/machine systems are to be disposed of/disassembled after the end of their useful life and which special features are to be taken into consideration.

Components, assemblies and devices must be recycled or disposed of in an environmentally friendly manner. Deviations must be approved by the Customer.

1.7.2 Energy efficiency

In the quotation, the Contractor shall describe the status quo of the machine/machine system in terms of energy efficiency. The consumption values for regular operation, as well as for partial load operation and idle running shall be indicated. All energy efficiency measures that have been performed on the machine shall be listed and divided into the following categories:

- Measures involving the use of corresponding hardware (e.g. pumps, motors, etc.)
- Measures involving shutdown strategies in partial load operation or during idle running (short-term standstill)
- Long-term shutdown (e.g. weekends) including automatic restart via the machine control unit.

In particular, the automatic deactivation of power consumers in standby mode, while guaranteeing a minimum (to-be-defined) run-up time for five-minute (or longer) short-term standstills (to be defined), and the automatic restart after long-term shutdowns shall be consistently implemented and demonstrated in accordance with quality requirements.

If the Contractor is aware of technical solutions which will not lead to a material change, this should be discussed with the Customer.

1.7.3 Work safety

1.7.3.1 Normative references

If there are any deviations from the applicable safety standards (e.g. C standards), documented proof must be presented that the same level of safety has been attained by different means.

As a basic principle, the requirements listed in the document "I General Information" regarding normative references apply.

1.7.3.2 CE marking

1.7.3.2.1 Operable machinery

The operable machinery/ assemblies of machinery must comply with the essential health and safety requirements of the applicable, valid EU Directives and it must have a CE marking in accordance with Annex II Declarations, 1. Content, A. EC Declaration of Conformity of the Machinery Directive (2006/42/EC). This shall also apply to the labeling requirement in accordance with other EU Directives.

All applied standards must be explicitly named in the EC declaration of conformity and the "Declaration of incorporation of partly completed machinery".

In the case that a chain connection of machinery (assemblies of machinery according to Machine Directive 2006/42/EC Annex 1, Chapter 1.2.4.4)) and assemblies of machinery (also older machinery) constitutes an essential element of the order, then the Contractor who received the order for the chain connection must perform the procedures for assessing conformity for the whole assemblies of machinery. The whole scope (listing of (partly completed) machinery and essential major components) must be defined in the EC declaration of conformity.

This is also valid for the respective specifications of other EU directives.

1.7.3.2.2 Risk assessment

The Contractor (taking into account EN ISO 12100 Safety of machinery - General principles for design - Risk assessment and risk reduction) shall give on request the risk assessment to the Customer at the latest upon conclusion of the design/engineering phase. It is a part of the machinery / assemblies of machinery technical documentation.

Design of control system safety shall be in accordance with EN ISO 13849.

For safety control systems or components with safety functions (e.g. safe drives) for which an examined and signed protocol (provisions of the component manufacturer) must be provided as proof of their safety status, the manufacturer shall hand over the protocol. The checksums of the protocol must correspond to the checksums of the machine. The volume and the mode of operation of each safety function must be documented.

All parameters which are relevant and described within the context of EN ISO 13849-1, such as PL, MTTFd, PFH, CCF, DC, T10d, B10d as well as the block circuit diagrams must also be delivered for

the respective subassemblies or corresponding safety function used. It must be possible to see clear references between the elements of the block circuit diagram and the real components (e.g. through stating the equipment designation (BMK) in the respective block circuit diagram to a safety function).

All components with safety functions must be unambiguously labeled in the equipment designation (BMK) with the suffix "SF". Additionally, a mark in yellow must be placed unambiguously and permanently (on and) next to these components. The equipment designation of the components in the circuit diagrams is to be applied in the SISTEMA project so that the components can be uniquely assigned.

From the Performance Level (PL) "d", the equipment must be designed for category 3 (redundant design).

The MTTFd must be designed for the following operating times of the machine:

- cycle time given in the requirement specification - Requirements for safety functions from setup frequency, interferences etc.
- 24 hours run-time per day
- 6 days / week
- 50 weeks / year

Replacement of safety components required for the necessary Performance Levels (PL) before the end of their statistical service life of 20 years is prohibited. Deviations must be released by the Customer. If the machine/machine system is not built according to the specifications of European guidelines, the Contractor has to prove that the safety-relevant specifications of the user's country are complied with.

1.7.3.2.2.1 Risk assessment (additional requirements for Germany)

Furthermore, the project planning for the safety functions with the IFA software "SISTEMA" as well as the protocols generated by SISTEMA must be provided. The SISTEMA project status must be "green".

1.7.3.2.3 Incomplete machines (partly completed machinery, additional requirements for Europe)

Machines/Machine systems that are not standalone as defined in the Machinery Directive (2006/42/EC) must comply with the basic safety and health requirements of the Machinery Directive (2006/42/EC) up to the interfaces described in the Contractor's technical documents (e.g. circuit diagrams, drawings, operating instructions, installation instructions). This is to be confirmed in the "Declaration for the installation of a partly completed machinery". The partly completed machine is to be delivered with operating instructions (according to 2006/42/EC, Chapter 1.7.4 ff).

1.7.3.2.4 Modifications

The risk assessment applies without restrictions to the scope of the modification, in the event of a material change to the complete machine.

1.7.3.2.4.1 Modifications (additional requirements for Europe)

If the Contractor is aware of technical solutions which will not lead to a material change, then this should be discussed with the Customer. (in the event... (CE marking) carried out on it by the Contractor.

In the event of a material change, a new machine is created for which the Contractor needs to carry out a Conformity Assessment Procedure (CE marking).

Rectifying defects which exist on the present machine which were possibly not known at the time of awarding the contract can not be charged to the Contractor.

The Customer must be aware of the safety-related condition of the machine/machine system before planning a modification.

1.7.3.3 Obligations regarding monitoring, inspecting, disclosure and permission

The machine/machine system must be ready for operation when delivered. This includes in particular all necessary pre-operation inspections and authorizations acc. to the statutory provisions effective on the site.

The Contractor must inform the Customer in writing about the obligations regarding monitoring, inspecting, disclosure and systems/parts subject to permission. If a regular inspection is required for the machine/machine system and/or its components, assemblies, devices, etc. (e.g. for centrifuges, pressure vessels, catch pans, cooling devices with contents of more than 3kg, etc.), this must also be listed in the technical documentation separately in the operating instructions and maintenance instructions.

Any necessary inspection books and the overview list containing all equipment requiring inspection/monitoring (Annex 2 of these Technical Delivery Specifications) must also be delivered with indication of the respective inspection intervals and included in the technical documentation of the machine/machine system.

1.7.3.4 Setup, service, maintenance work and troubleshooting

All standard activities linked to the operating conditions of the machine/machine system, such as setup, service and maintenance work, as well as troubleshooting, must be effected by the operating and maintenance personnel safely without manipulating protective equipment and, if possible, directly from the ground. Otherwise, the machine/machine system must have a safe ascent and a safe working platform installed (in accordance with EN ISO 14122 Sheets 1-4). If it is not technically possible to implement safe ascents and/or safe working platforms, then safe access and suitable anchor points (according to EN ISO 12100) need to be implemented.

If protection devices (e.g. manual control units) are required for setup, service and maintenance work (e.g. troubleshooting), the Contractor must include them in the scope of delivery.

1.7.4 Environmental protection

The unavoidable environmental impact caused by a machine/machine system must be kept to a minimum. Their type and scope must be named explicitly (e.g. waste, substantial emissions, noise). Any measures taken to prevent these from occurring must be documented.

All materials used in the machine/machine system must be recirculated in the material cycle or disposable in an environmentally friendly manner. Deviations must be discussed separately with the Customer.

When using fluids (cooling lubricant, hydraulic fluid, etc.), the seal integrity of all systems is especially important, i.e. the machine/machine system must not leak at any point in time.

1.7.4.1 Hazardous materials and working materials

Primarily, process materials must be used which have already been released by the Customer at the installation site.

Only components, assemblies and devices may be used with the machine/machine system that are free of CFCs, CHCs, asbestos and artificial mineral fibers with a carcinogenicity index CI < 40.

Containers and baths holding hazardous substances or mixtures must be permanently (indelibly) labeled with the name of the medium used and a hazard sign.

Pipelines carrying hazardous substances or mixtures must be permanently (indelibly) labeled with the name of the medium used and the flow direction. They also have to be resistant to medium and temperature. The conveyance of hazardous substances or mixtures in hose assemblies must be discussed with the Customer.

1.7.4.1.1 Hazardous Materials and Working Materials

With the comprehensive project-related offer, the Customer is to receive all pertinent, safety-relevant information (Material Safety Data Sheet (MSDS)) and/or current EC material safety data sheets (REACH Ordinance 1907/2006) relating to hazardous materials and working materials to be used. The documentation must be furnished for release purposes.

In addition, the Contractor must provide information concerning

- purpose and
- frequency of use

1.7.4.1.2 Hazardous and working materials (additional requirements for Germany)

The technical documentation must include information on the VOC share and the water pollution category. The substitution provisions in accordance with the Hazardous Substances Ordinance must be observed. The ChemVerbotsV (German Chemicals Prohibition Ordinance) is also applicable. These requirements only apply for Germany.

General Part

1.7.5 Physical effects

1.7.5.1 Noise – objectives of the noise emission requirements

(Also refer to Annex 5_Measurement Report :Annex 5_Noise_Measurement_Report-2015.xlsx")

- The objective is to ensure and maintain low-noise and low-vibration workstations. To this end, ZF Friedrichshafen AG shall observe the national legal limit values for noise at the workplace of the respective locations. In Europe, the EC directive "2003/10/EC" forms the basis.
- The avoidance of noise emissions and the observance of national legal emission/immission requirements at the respective ZF locations. (Germany: TA Lärm - Technical Instruction on Noise Protection)

1.7.5.1.1 Machines / Machine Systems

Basis for the assessment is DIN EN ISO 4871 ("Acoustics - Declaration and verification of noise emission values of machinery and equipment (ISO 4871:1996); German version EN ISO 4871:2009").

1.7.5.1.2 Machines and systems in closed workshops

Workplace-related emission sound pressure level

- Irrespective of the operating state of the machine/machine system, a workplace-related emission sound pressure level L_{pAeqT} of max. 76 dB(A) shall be complied with at the workplace of the machine/machine system operator.
- Determined according to EN ISO 9612 and/or EN ISO 11 200 ff.

Machine-related emission sound pressure level

- Irrespective of the operating state of the machine/system, an emission sound pressure level L_{pAeqT} of max. 78 dB(A) shall be complied with within a distance of 1m from the machine/machine systems surface.
- Determined according to DIN 45645-2, EN ISO 9612 and/or EN ISO 11 200 ff.

Tone incorporation

Irrespective of the operating state, the emission of pronounced individual tones that are subjectively perceived as a nuisance is to be avoided. Emission sound pressure levels at the measurement locations which contain tonal components shall be documented separately in the inspection/acceptance protocol.

Noise peaks

Irrespective of the operating state of the machine/system, single, short and irregularly occurring noise peaks must not exceed a level of $L_{pC,peak} = 135$ dB(C).

1.7.5.1.3 Machines and systems outside of buildings and closed workshops

This matter shall be coordinated with the Customer for individual projects.

All machines/machine Systems that are to be installed outside of buildings as well as all supply/exhaust
air and exhaust gas inlets/outlets and/or all lines or conveyor systems running outside of buildings and EN

conveying solid, liquid or gaseous media must be designed with state-of-the-art mufflers and/or sound insulation. All system components must be mounted to buildings and other supporting structures including state-of-the-art vibration isolation.

ZF Friedrichshafen AG assesses compliance with the immission guide value based on the noise data provided by the supplier and on the basis of the locally applicable legal requirements.

The sound pressure level (L_{pAeqT}) and/or the sound power level (LWA) shall be indicated as third octave spectrum. Documentation shall be provided for an operating point under full load as well as for a noise-critical operating point under partial load that is defined by the Customer.

The impulsiveness of noise emissions shall be indicated.

1.7.5.1.3.1 Machines and machine Systems outside of buildings and closed work halls (additional requirements for Germany)

Compliance with the immission guide value is assessed by ZF Friedrichshafen AG on the basis of the noise data provided by the supplier.

1.7.5.2 Building vibrations

Machines and systems which may emit considerable building vibrations must be suitably decoupled in terms of vibration engineering. The Customer must be informed in good time of any measures it may be necessary to take regarding the building and these must be discussed with the Customer.

1.7.5.2.1 Building vibrations (additional requirements for Germany)

In order to prevent any impact on the neighborhood, the reference values provided by DIN 4150 must be met.

1.7.5.3 Use of energy/heat

Residual heat quantities dissipated via emissions must be quantified and used within the process as far as possible. Here, the Contractor will work out a concept for the use of heat and/or is obliged to actively cooperate in the establishment of such a document.

Measures and actions geared towards saving energy, in accordance with the state of technology, must be seized.

1.7.5.4 Electromagnetic fields

If this information is not safety-relevant, then evidence has to be provided e. g. in the risk assessment. Otherwise, measurement values and exposition areas must be provided.

1.7.5.4.1 Electromagnetic fields (additional requirements for Germany)

Otherwise, measurement values and exposition areas must be provided.

1.7.6 Suction/extraction units

The required suction/extraction and filter systems must already be separately included in the quotation. The requirements in the other parts of this delivery specification and location-specific provisions must be considered. The decision on the type and design of an suction/extraction system shall be made coordinated with the Customer.

If explosive dust/air mixtures or vapor/air mixtures are exhausted or if such mixtures may be produced during the suction/extraction process, then the directives for explosion protection must always be taken into consideration.

The filter systems (pipelines, filter material) must be made of non-flammable material. Baffles and flame barriers are preferable to fire shutters, in particular if there is central extraction, or should be used in addition. Machine-related inertizing extinguishers (e.g. CO₂ extinguishing systems) are to be integrated into the extraction unit in agreement with the Customer (additional extinguishing nozzles). Installations to monitor the air flow rate must be provided.

The standards to be applied, i.e. EN ISO 14123-1 Safety of machinery - Reduction of risks to health resulting from hazardous substances emitted by machinery - Part 1: Principles and specifications for machinery manufacturers and EN ISO 14123-2 Safety of machinery - Reduction of risks to health resulting from hazardous substances emitted by machinery - Part 2: Methodology leading to verification procedures are to be considered.

1.7.7 Pipelines

Pipelines must be slightly inclined, without recesses and as straight as possible. Pipelines which are more than five meters long or have multiple bends must have revision openings.

1.7.8 Air volume

Prerequisite for starting the machine is a running extraction system in compliance with the minimum volume flow / exhaust air flow specified by the machine manufacturer (control e.g. by means of a pressure or flow monitor). If the required exhaust air flow is fallen short of or in the event of a malfunction, the machine must stop operation.

Measuring points must be set up before and after the filter for monitoring.

1.7.9 Specifications for machine components

1.7.9.1 Laser

The Contractor must provide unambiguous information about the laser equipment including statements regarding the laser classes.

If possible, laser radiation in the direction of workers should be avoided. Disturbance due to reflected laser radiation is to be avoided.

For lasers with laser class ≥ 2 , there must be a clearly visible warning marking on the laser and, if necessary, at the deflection point.

In addition, the laser must be marked on the system if the warning marking cannot be clearly attached. The currently harmonized standards are to be applied.

1.7.9.1.1 Laser (additional requirements for Germany)

The DGUV 11 regulation is to be considered in Germany.

1.7.9.2 Robots

1.7.9.2.1 General principles

Robots are to be equipped with a secure control unit at least in PL d (category 3 (redundant design)).

EN ISO 10218 (Industrial robots), Parts 1 and 2 must be taken into consideration.

1.7.9.2.2 Size and properties of the protective fence

If a secure control unit is not available:

- The protective fence must be higher than the mechanical scope of the robot. If this can not be realized, the manufacturer must prove that the protective fence is (calculated to be) strong enough.
- If the robot has corresponding axis limit switches or axis stops, strength verification is not necessary.

- The protective fence must be at least 2 200 mm high. The gap to the floor may be max. 200 mm. If there is any danger of parts being ejected by the robot, e.g. during overhead movements, this must be considered in the geometry (dimensions) and stability of the protective fence.

1.7.9.2.3 Access points to the robot cell

Preferably, a robot cell should only have one access point.

If several access points are required, control engineering is to be used to ensure that the robot drives are safely switched off when these additional access points are opened.

Test or teach operation may only be possible when the additional access points are closed.

There must be a holder for the manual programming device on the outside of the access point.

1.7.9.2.4 Test2 operation (moving the robot at process speed when the protective door is open)

For handling robots, Test2 operation (at process speed) should always be deactivated. Test2 operation (moving the robot at process speed when the protective doors are opened) For handling robots, Test2 operation (at process speed) should always be deactivated. In the case of welding, gluing or similar application, the manual movement speed in Test2 operation should be limited to the necessary process speed.

1.7.9.2.5 Robot operating modes

Basically, the operating modes "Automatic" and "Setup" or "Teach operation" should be provided for in the robot control. If other operating modes e. g. "Manual loading of systems within the robot cell" are required, these additional operating modes should be considered in the robot control unit.

1.7.10 Linear systems/ Gantry loaders

Interlinking machines using gantry loaders which travel over protected areas.

1.7.10.1 Automatic mode

In automatic mode, workpieces must be prevented from falling down or being ejected. The gantry loaders are to be secured in PL d (control category 3) at minimum. Special attention should be paid to combined movements (e.g. turning and moving). If it cannot be ensured that the workpiece has been securely gripped, additional measures need to be taken, e.g. on the guards.

Workplaces, passage ways or travel paths underneath the traverse path of the gantry loaders must be secured with guards of sufficient strength.

Safety distances as per EN ISO 13857 must be adhered to.

1.7.10.2 Setup/Service/Maintenance, including troubleshooting

Machine working areas which are traversed by the gantry loader and which have to be entered while the gantry loader is operating must be secured using mobile guards of sufficient strength.

The manufacturer is to define a safe parking position for maintenance work.

Safe access for maintenance and repair work must be ensured by the supplier (maintenance passage way, walkway, in accordance with Machinery Directive 2006/42/EC, Annex I, Chapter 1.6.2, EN ISO 12100, Chapter 6.3.5.6 and the EN ISO 14122 series of standards).

1.7.10.2.1 Setup/Service/Maintenance, including troubleshooting)

The supplier must ensure safe access for maintenance and repair work (maintenance gangway and walkway: in the EU in accordance with Machinery Directive 2006/42/EC, Annex I, Chapter 1.6.2, EN ISO 12100, Chapter 6.3.5.6 and the EN ISO 14122 series of standards).

1.7.11 Chip conveyor

Chip conveyors in the area of chip ejection are to be secured according to the specifications of DIN EN ISO 13857 (it must not be possible for staff to make any kind of movement that may endanger humanbody parts). If necessary, safe access options for troubleshooting must be provided according to the Machine Directive 2006/42/EG (e.g. by means of chip hooks for jammed flow chips). Furthermore, an electric switch with emergency stop function is to be provided in the area of the chip ejection:

- Position 1 locked (automatic mode)
- Position 0 locked and lockable (chip conveyor OFF)
- Position 2 pushbutton function (chip conveyor reverse mode)

When selecting or designing the chip conveyor, the type of chips must be taken into account and agreed on with the Customer.

1.7.12 Protective devices

1.7.12.1 AOPD (active optoelectronic protective devices)

The Customer is to be sent the measurement report, according to the standards in Part I General Information, Chapter 6.2 of this Delivery Specification before the test run. The position of the transducer and the underlying hazard point shall be documented in the measurement report and marked on the machine. Information about the safety distance and overrun time shall be attached to the machine. An inspection tag is installed on the AOS. It may only be installed if the inspection was passed. A stop time measurement to calculate the safety distance is to be carried out on active optoelectronic protective devices (e. g. light curtains, light grids) before carrying out the test run at the suppliers'. The Customer is to be sent the measurement report, according to the specifications in Chapter I General Information, before the test run. The position of the sensor (e.g. plunger, flag) and the underlying hazard point shall be documented in the measurement report and marked on the machine. Information about the safety distance and stop time shall be attached to the machine. An inspection tag is installed on the AOS. It may only be installed if the inspection was passed.

1.7.12.2 Tow-hand control

The standards set out in the chapter are applicable (*refer to section AOPD (active optoelectronic protective devices) , page 25*) analogously.

1.7.12.3 Guards

Guards must be attached to the floor. Attaching them to machine parts must be avoided.
Conduits

Ducts, empty conduits, piping for energy supply etc. may not be attached to removable protective devices (e.g. segments of a fixed distance guard) if access for maintenance or service work is only possible through these.
Conduits Cable ducts, empty tubes, pipelines for energy supply etc. may not be attached to removable protective devices (e.g. segments of a protective fence) if access for maintenance or service work is only possible through these.

1.7.12.4 Safety Windows

1.7.12.4.1 Strength

The strength of the screening grid used in the machine/machine system must comply with the latest version of these European standards

- EN ISO 23125 for lathes
- EN 12417 for machine centers.

The retention ability of the applicable screening grid must be ensured for every possible stress/load.

For all other machines/machine systems, the design must comply with the recommendation of the "screening grids" VDW working group in the absence of any relevant international standards. The strength of the safety window used in the machinery/assemblies of machinery must be designed with the latest version of applicable European standards and the retention capability of the safety window must be ensured for every possible kind of stress/load

Standard

EN ISO 14120 Safety of machinery – Guards – General requirements for the design and construction of fixed and movable guards

- General requirements for the design and construction of fixed and movable guards

1.7.12.4.1.1 Strength (additional requirements for Germany)

latest version of applicable European standards and the retention capability of the safety window must be ensured
guards" VDW working group in the absence of any relevant international standards.

1.7.12.4.2 Resistance

In the interior of the machine/machine system, screening grids (laminated glass made of mineral glass and polycarbonates) must be resistant over a minimum term of 5 years against coolants, vapors emitted by coolants, chips and other lifetime-reducing impacts. The replacement date must be stated visibly on the screening grids.

Safety Windows (multilayer glass made of mineral glass and polycarbonates) in machinery/assemblies of machinery must be resistant over a minimum term of 5 years against coolants, vapors emitted by coolants, chips and other lifetime-reducing impacts from the interior. The replacement date must be stated visibly on the safety window.

1.7.13 Fire and explosion hazard

The Contractor shall perform a risk assessment of fire and explosion hazards from gases, vapors, mist (aerosols) and flammable dust for machines/machine systems. In coordination with the Customer, the Contractor shall create an action plan to prevent or minimize damage associated with these risks.

If explosive dust/air mixtures or vapor/air mixtures are extracted or if such mixtures may be produced during the extraction process, the directives for explosion protection must always be considered.

If there is any risk of explosion, additional (one or more) pressure relief flaps (EX flaps) are required on the machine covering. The pressure relief flaps are to be aligned in such a way that a pressure surge which escapes through them does not present any kind of hazard to people. Machine paneling must be designed to be shot-proof and flame-proof. The conditions at the later point of installation of the machine/machine system (in particular fire protection) must be taken into consideration for the positioning of the pressure relief flaps. To minimize the spread of fires, housing seals are to be designed as labyrinth seals (door labyrinths). Moreover, it must be ensured that in the case of a deflagration/explosion, flames cannot get into the filter system via the extraction equipment.

The filter systems (pipelines, filter material) must be made of non-flammable material. Baffles and flame barriers are preferable to fire shutters, in particular if there is central extraction, or should be used in addition. Machine-related inertizing extinguishers (e.g. CO₂ extinguishing systems) are to be integrated into the extraction unit in agreement with the Customer (additional extinguishing nozzles). Installations to monitor the air flow rate must be provided.

1.7.13.1 Fire and explosion hazard

In the case of machines/machine systems with explosion areas, an explosion zone plan (classification of hazardous areas) must be supplied.

1.7.14 Ergonomics

All aspects of ergonomics must be taken into consideration when designing the machine/machine system.

Working spaces within machines/machine systems must be lit up appropriately for the respective task, but at least with 300 lux.

If there are any deviations from these values, the Contractor must contact the Customer.

1.7.14.1 Ergonomics (additional requirements for Europe)

For individual issues, the following, experience-based reference values have proven to be feasible:

- Loading and unloading height: 950 mm – 1 100 mm
- Screen (upper edge, top legible line): min. height 1 400 mm, max. height 1 650 mm
- Depth of legroom: min. 210 mm
- Insertion depth / gripping space: max. 450 mm

If there are any deviations from these values, the Contractor must contact the Customer.

1.7.15 Immission control

The release of pollutants to the atmosphere is only permissible if it can be proven that recirculating air operation is technically/economically not feasible.

The required suction/extraction and filter systems must already be separately included in the quotation. The requirements in the other parts of these delivery specifications (e.g. mechanics) and location-specific provisions must be considered. The decision on the type and design of a suction/extraction system shall be made coordinated with the Customer.

Agreements shall be reached with the Customer on how the immission standards as defined by law shall be observed.

The machine/machine system working space must be designed so that air-polluting and environmentally hazardous materials do not escape.

1.7.15.1 Immission control (additional requirements for Germany)

Basis for Germany are TA Luft, TA Lärm, 26. BImSchV (Federal Immission Control Ordinance), the official land-use plan for the installation site, the distance from the nearest residential building and, if available, the building development plan in its latest applicable version.

1.7.16 Handling materials hazardous to water

1.7.16.1 General Requirements

Special requirements for machines/machine systems in protected/conservation areas (e.g. FFH (Europe) or water protection zones (Germany) or similar) must be taken into account after consultation with the Customer.

If substances hazardous to water are used in the machine/machine system including all associated auxiliary equipment, then suitable protective equipment (e.g. catch pans) must be included in delivery.

1.7.16.1.1 General requirements (additional requirements for Germany)

These must be designed in accordance with §§ 62 and 63 WHG (Federal Water Act) and Federal State VAWS (Ordinance on installations for handling of substances hazardous to water). According to Federal State VAWS, only specialists may be commissioned for their installation, setup, servicing, repair or cleaning.

The Contractor must present proof of specialist licensing to the Customer without being asked.

With the entry into force of the national AwSV ordinance, which will replace the Federal State VAWS ordinances, the national ordinance shall be applicable.

1.7.16.2 Retaining equipment

Collecting trays and drip plates below conveyor belts must propensity at least 3%.

The volume of the collecting trays or containers must be designed according to the legal regulations valid for the installation site.

As a basic principle, floor drains are not allowed.

Retaining equipment must be durably sealed and media-resistant. The corresponding evidence (e.g. inspection certificates, static calculations, construction descriptions, licenses) must be provided to the Customer without being asked for.

When coating is used for the collecting trays, the Contractor must comply with the building inspection permit (e.g. labeling the coating, type approval).

1.7.16.2.1 Retaining equipment (additional requirements for Germany)

As a basic principle, the requirements of national VAWS, TRwS 779, DWA-A 786 and steel tub guidelines apply to the collecting trays required by water law. Only applicable in Germany.

1.7.17 Cooling and heating systems

If cooling systems are required for the operation of the machine/machine system, they must be designed to produce low losses and little wastewater.

The chemicals to be used require a special approval to be obtained by the Customer.

The following information must be provided by the Contractor: Additional chemicals to be used (generation of algae, corrosion protection etc.), wastewater volumes for regeneration, and the regeneration cycle.

Special requirements (e.g. installing a safety heat exchanger) must be coordinated with the Customer for cooling and heating the machines/machine systems, especially those systems using substances hazardous to water.

1.7.17.1 Cooling and heating systems (additional requirements for Germany)

The 42nd B1SchV as well as the VDI 2047 sheet 2 is to be considered in Germany.

1.7.18 Waste

In general, the avoidance/minimization/use regulation (in Germany acc. to. the Federal Recycling Act) shall be observed (e.g. by extending service life of cooling lubricants in machines/machine systems or using maintenance-free filters).

General Part

Before starting work, the Contractor must coordinate with the Customer how to expertly and legally dispose of any kind of waste resulting from building measures, installation, mounting, or dismantling the machine/machine system. Transport containers shall be taken back by the Contractor after delivery.

1.7.19 Power

The machine/machine system must be energy-efficient in both its design and operation. In the quotation, the Contractor shall separately list any additional units that can help save energy.

1.7.20 List of abbreviations

Abbreviation	Explanation
AD	Working group on pressure vessels
ATEX	ATmosphère Explosive
BImSchG	Federal Immission Control Act
BImSchV	Federal Immission Control Ordinance
BMAS	Federal Ministry of Labor and Social Affairs
CE	Communauté Européene or Conformité Européene
ChemOzonSchichtV (German Chemical And Ozone Layer Regulation)	Ordinance on materials which damage the ozone layer
ChemVerbotsV (German Chemicals Prohibition Ordinance)	The Regulation on Prohibited Chemicals prohibits or limits the distribution of hazardous substances, preparations and products in accordance with the Law on Chemicals
DGUV	German statutory accident insurance DGUV Regulation DGUV Guideline DGUV Information
DIN	German Institute for Standardization
DWA-A	Worksheet of the German Association for Water Management
EC	European Community
EU	European Union
EN	European Standard
GUV	Standards of the statutory accident insurance
ISO	International Organization for Standardization
ProdSG	Product Safety Act
RL	Guideline
TA	Technical instructions
TRBS	Technical Rules for Operational Safety
TRGS	Technical regulations for hazardous substances
TRwS	Technical regulations for water-hazardous substances
VAwS	Ordinance on Facilities For Handling Substances Hazardous to Water
VDA	German Association of the Automotive Industry
VDA-LVE	Supply specifications for electric equipment of machines, machine systems and equipment
VDE	Association for Electrical, Electronic & Information Technologies
VDI	Association of German Engineers
WHG	Federal Water Act

Table 4 Abbreviations

1.7.21 Annex: Other Applicable Documents

For orientation purposes, the Annex states some of the important legal, international and national provisions/directives without claiming completeness.

1.7.21.1 Globally valid standards

Standard	Description
EN ISO 4414	Pneumatic fluid power - General rules and safety requirements for systems and their components
EN ISO 10218-1	Robots and robotic devices - Safety requirements for industrial robots - Part 1: Robots
EN ISO 10218-2	Robots and robotic devices - Safety requirements for industrial robots - Part 2: Robot systems and integration
EN ISO 12100	Safety of machinery - General principles for design - Risk assessment and risk reduction
EN ISO 13857	Safety of machinery - Safety distances to prevent hazard zones being reached by upper and lower limbs
EN ISO 13849-1	Safety of machinery - Safety-related parts of control systems - Part 1: General principles for design (ISO 13849-1:2015)
EN ISO 13849-2	Safety of machinery - Safety-related parts of control systems - Part 2: Validation (ISO 13849-2:2012)
EN ISO 14120	Safety of machinery - Guards - General requirements for the design and construction of fixed and movable guards
EN ISO 14122-1	Safety of machinery - Permanent means of access to machinery - Part 1: Choice of fixed means of access between two levels
EN ISO 14122-2	Safety of machinery - Permanent means of access to machinery - Part 2: Working platforms and walkways
EN ISO 14122-3	Safety of machinery - Permanent means of access to machinery - Part 3: Stairs, stepladders and guard-rails
EN ISO 14122-4	Safety of machinery - Permanent means of access to machinery - Part 4: Fixed ladders

Table 5 Globally valid standards

1.7.21.2 Legal requirements (additional requirements for Europe)

Re. (refer to section CE label, page 16)

Directives

- Directive 2001/95/EC of the European Community on product safety in general
- Directive 2006/42/EC of the European Community on machines (Machinery Directive)
- Directive 2014/35/EU of the European Parliament and of the Council on the harmonization of the laws of the member states relating to the making available on the market of electrical equipment designed for use within certain voltage limits (EU low-voltage directive)
- Directive 2014/30/EU of the European Parliament and of the Council on the harmonization of the laws of the member states relating to electromagnetic compatibility.
- Directive 2014/68/EU of the European Parliament and of the Council on the harmonization of the laws of the member states relating to the making available on the market of pressure equipment
- Directive 2014/29/EU of the European Parliament and of the Council on the harmonization of the laws of the member states relating to the making available on the market of simple pressure vessels
- Directive 2014/34/EU of the European Parliament and of the Council on the harmonization of the laws of the member states relating to equipment and protective systems intended for use in potentially explosive atmospheres (ATEX directive)

Standards

EN 60204-1: Electrical equipment of machines

1.7.21.3 Other applicable documents

Standard	Description
DIN EN ISO 216	Writing paper and certain classes of printed matter - Trimmed sizes - A and B series, and indication of machine direction
DIN EN 60848	GRAFCET - Specification language for sequential function charts
DIN EN 61082	Preparation of documents used in electrotechnology
DIN EN 60204	Safety of machinery - Electrical equipment of machines - Part 1: General requirements
DIN ISO 1219-1	Fluid power systems and components - Graphic symbols and circuit diagrams - Part 1: Graphic symbols for conventional use and data-processing applications
DIN ISO 1219-2	Fluid power systems and components - Graphic symbols and circuit diagrams - Part 2: Circuit diagrams
DIN EN ISO 12100	Safety of machinery - General principles for design - Risk assessment and risk reduction
DIN EN ISO 13849-1	Safety of machinery – Safety-related parts of control systems-Part.1: General principles for design

Table 6

1.7.21.4 Other applicable documents (additional for Europe)

EN 13478, Safety of machinery, Fire prevention

1.7.21.5 Other applicable documents (additional for Germany)

- VDA-LVE
- DIN 45681, Acoustics - Determination of tonal components of noise and determination of a tone adjustment for the assessment of noise immissions
- DIN 4150, M1867 Vibrations in buildings, including the standards, target specifications and recommendations contained therein.

Currently valid German standards shall apply until they are replaced by harmonized European or international standards.

Special attention shall be given to:

- Drafting the inquiry and offer:
VDI 2856, Standardized specification for inquiries and offers on machine tools
- Professional associations' regulations
 - DGUV Regulation 3, Electrical installations and operating materials
 - DGUV Regulation B11, Electromagnetic fields
 - DGUV Information 2090-69 (5048), Ergonomic machine design

1.7.21.6 Design of safety guard strength,

e. g. according to EN ISO 14120 Safety of machinery - Guards - General requirements for the design and construction of fixed and movable guards

1.7.21.7 Legal requirements (additional requirements for Germany)

In Germany, EC Directives are implemented by enacting the respective directives for ProdSG (Product Safety Act), EMC-G etc.

The Contractor is responsible for the proper functioning of the machine/machine system and for maintaining the regulations that are valid when the contract is signed, such as e.g.:

- Product Safety Act (ProdSG)
- Interpretation paper on the subject of Entirety of Machines, - Publication by the Federal Ministry of Labor and Social Affairs dated 2011-05-05 – IIIb5-39607-3 -
- Federal Water Act (WHG)
- German State Water Law, German State or national Ordinance on installations for handling of substances (Landes-VAwS or Bundes-AwSV respectively)
- TRwS 779 (Technical rule for substances hazardous to water) for systems used to handle liquid and solid substances hazardous to water
- DWA-A 786 Worksheet to TRwS 779
- Steel tubs guideline (StawaR)
- Waste Water Ordinance incl. Annexes
- Drainage or waste water statutes applicable to the installation site
- ChemOzonSchichtV (German Chemical And Ozone Layer Regulation)
- ChemVerbotsV (German Chemicals Prohibition Ordinance)
- Ordinance governing electromagnetic fields (26.BImSchV Federal Emissions Protection Law).
- Other laws applicable to the installation site.
- State of the art, including:
 - EN standards
 - VDE provisions
 - DIN standards
 - VDI guidelines:
 - VDI Guideline 2243, "Recycling-oriented product development", Designing of recycling-compliant technical products, Basics and design rules
 - VDA guidelines
 - DGUV regulations/DGUV rules
 - BImSchG
 - 26th BImSchV (Federal Immission Control Ordinance)
 - TA Lärm (Technical Instruction on Noise Protection)
 - TA Luft (Technical Instructions on Air Quality Control)
 - AD 2000 set of rules.
 - Technical regulations (TRBS, TRGS, TRwS, ...)
 - For technical design:
 - DIN 33411-5, Physical strength of man - Part 5: Maximal isometric action forces, values

1.8 Documentation

1.8.1 Scope and time of delivery

One copy of the technical documentation shall be delivered on paper and on a data carrier. The scope and time of delivery of the technical documentation are defined in Annex 1 (Scope of Documentation) and must always be coordinated with the Customer.

For ready-for-operation delivery, all documentation required for commissioning/marketing (e.g. Operating Instructions, CE marking) must be available.

The scope and time of delivery of preliminary documentation are likewise defined in the Scope of Documentation (Annex 1).

1.8.2 Language

All documents shall be written in the language used at the location (in compliance with the European product directives).

A separate agreement must be made with regard to choice of language for international sites (sites outside the EEA).

1.8.3 Structure

The technical documentation must be structured. Here, the folder structure predefined by ZF Friedrichshafen AG is binding.

Folder structure:

- 1 Mxxxx
- 100-General
 - 1 01-Operating Instructions
 - 1 02-Maintenance Plan
 - 1 03-Setup Instructions
 - 1 04-Setup documentation
 - 1 05-Replacement Wear Parts Lists
 - 1 06-Machine Setting Data
 - 1 07-Third Party Documentation
- 101-Electrical Engineering
 - 1 01-Circuit Diagrams
 - 1 02-PLC 1 03-NC
 - 1 04-Safety Control System
 - 1 05-Manuals - System Description
 - 1 06-Interface Description
- 102-Mechanics
- 103-Hydraulics
- 104-Pneumatics
- 105-Lubricating Technology

- 106-Cooling Lubricating Technology
- 107-Occupational Safety, Fire and Environmental Protection
- 108-Protocols
- 109-ZF-internal Documentation

1.8.4 Format of the documents (additional requirements for Europe)

Subject to the Customer's input, all documents – except drawings – shall preferably be created in DIN A4 (acc. to DIN EN ISO 216).

Drawings in the technical documentation must be at least in DIN A3 (acc. to DIN EN ISO 216) or original size.

1.8.5 Filing of the documents (additional requirements for Germany)

The documents must be grouped in stable files or ring binders made of cardboard with 4 rings and include a table of contents and register (including third-party documentation).

1.8.6 Label

The files must be numbered in sequence incl. the total number.

1.8.7 Revisions and modifications

All changes made to the machine/machine system during manufacture, installation, assembly, startup and trial operation at the Customer's site must be immediately added to the relevant technical documents by the Contractor.

The final technical documentation must match the state of the machine/machine system at the time of acceptance.

If at a later time, which may even follow the warranty period, it is discovered that the documents provided by the Contractor do not match the delivered object, the Contractor must pay for any reworking or replacement of the technical documents.

Provided nothing else has been agreed with the Customer, any changes, extensions or modifications to existing machines/machine systems shall be made in the relevant technical documents with the original drawing and designation system.

1.8.8 Contents of technical documentation

1.8.8.1 General Information

1.8.8.1.1 Operating instructions

The operating instructions must also include all necessary information on how the machine/machine system can be reset to home position or restarted after a malfunction.

Furthermore, all operating station functions (initiated both via switch elements as well as via visual display) must be described along with any important information with regard to reciprocal interlockings.

1.8.8.1.1.1 Operating instructions (additional requirements for Europe)

The requirements from the Machinery Directive and applied standards shall be considered in the operating instructions.

1.8.8.1.2 Maintenance schedule

In the maintenance plan register, among other things, the operator's maintenance plan, the maintenance instructions and the service and maintenance plan are to be filed.

1.8.8.1.3 Operator's maintenance plan

The operator's maintenance plan contains the inspection and maintenance work to be performed by the operator. If applicable, the Contractor's respective form shall be used.

All necessary/planned steps including steps by subcontractors and suppliers must be compiled in a central list. Otherwise, the Customer is not required to observe them.

1.8.8.1.4 Maintenance instructions

Special information on expert inspection, maintenance and repair of the machine/machine system. Diagnostic aids, error lists and detailed error descriptions in the case of malfunctions.

Also a list of necessary project planning software (e.g. for visual displays, axis assemblies, frequency inverters) and communication software (e.g. for CPs, COM software).

Also include any necessary adjustment and alignment aids for machine components.

1.8.8.1.5 Service and maintenance plan

The service and maintenance plan contains the inspection and maintenance to be performed by the maintenance technician. If applicable, the Customer's respective form shall be used.

All necessary/planned steps including steps by subcontractors and suppliers must be compiled in a central list. Otherwise, the Customer is not required to observe them.

1.8.8.1.6 Setup instructions

Description of a chronologically optimal setup operation agreed with the Customer.

1.8.8.1.7 Installation documentation

1.8.8.1.7.1 Operating sheet (job card) for space and installation planning

The operating sheet for spatial and installation planning (Annex 3) must be filled out based on the Customer's template. Any changes must be updated immediately.

1.8.8.1.7.2 Transport, installation and assembly instructions

The technical documentation shall contain information on proper transport, installation and assembly.

1.8.8.1.7.3 Foundation drawings

The basic requirements for the foundation are to be included in the foundation drawings (stiffness, recesses, precision, loads in general and at specific points, calculation results (dynamic)).

The Customer will define the main axes X, Y for the dimensions based on the respective plant system. All dimensions must be based on these axes and heights.

1.8.8.1.7.4 Installation plan/layout

Installation plan and layout of the machine/machine system based on the Customer's template. A complete and an abridged version are to be delivered in each case.

If statics are required and commissioned by the Contractor, they must be included in delivery.

The following points are to be observed:

- Drawing to scale
- Format: DWG (or DXF)
- Maintenance interfaces drawn in
- Contents reduced to a few external contours
- User interface (side) must be visible
- Machine axes drawn in
- Statics: data on static and dynamic loads and location of impact.

1.8.8.1.8 Spare and wear parts lists

Critical spare and wear parts shall be identified by the Contractor using the ZF ABC risk analysis for spare and wear parts lists (Annex 5) for each machine type. The analysis is to be conducted according to the ZF standard template and made available after the design release, at the latest before the ZF delivery approval (exclusively in the predefined Excel format, changes to the table are not allowed).

1.8.8.1.9 Machine setting data

This includes setting parameters like pressures, flow volumes, parameter lists for electric systems and workpiece-specific data.

1.8.8.1.10 Third party documentation

Technical documents of assemblies and components provided by subcontractors, such as control components, chip conveyors, measurement control, servo valve, etc., shall be included in delivery and filed separately, if necessary. These documents must include setting information and function descriptions. Furthermore, the same provisions as for the Contractor apply.

Providing general catalogs is not sufficient.

1.8.8.1.11 Function plans

The functions are to be described. The on and off conditions as well as control and locking conditions must be clearly stated.

The function plan must essentially contain: function process/sequence, mechanical ratings, drive ratings, auxiliary device ratings and a brief description of control devices inasmuch as they are hydraulically, pneumatically or electrically operated.

Parts that are not included in the Contractor's scope of delivery must be marked in the function plan.

The function plan must be extensive enough that the electric control can be implemented based on this description.

A function description shall be added to the function plan at the request of the Customer.

1.8.8.2 Electrical engineering system

1.8.8.2.1 Circuit diagrams / Parts list (additional requirements for Europe)

The circuit diagram as well as the parts list and its description must comply with DIN EN 61 082.

1.8.8.2.2 Circuit diagrams / Parts list [BoM]

Creation in E-Plan, as of version P8. The version must be agreed upon with the Customer.

The structure should at least contain the following:

- Cover sheet
- Supplements/Comments (with order data, wire colors, fuse protection, performance data, software and software versions used)
- Table of contents
- Revision list
- Switch cabinet design drawings
- Mounting plates, panels and terminal boxes; assignment diagram of components outside of switch cabinet; circuit diagrams; routing diagrams signal exchange; installation plan, connection diagrams and terminal diagrams
- Parts list with manufacturer data.

The following information must be included in the circuit diagrams: Voltages, frequency, nominal currents of fuses, ratings and settings (e.g. motors, etc.)

Bus structures and the hardware setup of the visual display system shall be depicted in the circuit diagram.

The delivered hardware and firmware versions and the hardware setting (DIL switch) shall be noted in the circuit diagram for all intelligent assemblies (also PC).

Component or location identification must be based on location or sheet.

ZF sample templates can be provided upon request P8 sample project.

The PLC inputs/outputs shall be illustrated as a linked, continuous block.

The designation between sensor/actuator level and PLC/control must be intuitively consistent/uniform.

1.8.8.2.3 PLC documentation

The PLC programs must be saved in current SPS format and delivered on data carriers.

Hard drive contents of PC-based systems (e.g. robot control units) must be delivered as a hard drive image on a data carrier.

The program printout in PDF format must contain the following:

- Assignment list
- Step chain structure with and without actions
- Organization component (OB1, OB100)
- Function components (FC, FB without standard FB)
- Reference list
- Bus structure (participant overview)

- Third-party components

1.8.8.2.4 NC documentation

The NC documentation includes:

- NC and PLC volume production startup files
- PLC program in current SPS format
- NC programs and all data relevant to the operation of the machine/machine system.

1.8.8.2.5 Safety control system

For the safety control program, all passwords must be provided.

The validation documentation must also be supplied.

1.8.8.2.6 Manuals and system descriptions

A basic software license shall be included in delivery for all operating systems, visual display systems and software of all programmable systems.

The scope of supply includes manuals and system descriptions, data carriers? Files? bootable media, used drivers (GSD files), the description of structure/file storage.

1.8.8.2.7 Interface description

The interface descriptions shall be coordinated among the Contractors and submitted for approval. They must be incorporated in the documentation of all contractors. The designation and pin assignment must be consistent.

1.8.8.3 Mechanics

1.8.8.3.1 Assembly drawing/Parts lists [BoM]

The assembly drawings and, if applicable, exploded diagrams must clearly show how the components can be disassembled and assembled. The reference to the parts list must be indicated.

1.8.8.3.2 Subassembly drawing/Parts lists [BoM]

Drawings of assemblies with weight data shall be made for the individual assemblies, transport plan, connection points, load data and service life data.

1.8.8.4 Hydraulics

1.8.8.4.1 Circuit diagrams/Parts lists [BoM]

Circuit diagrams and BoMs shall be displayed in E-Plan as of version P8 as defined by DIN ISO 1219-2. The version must be agreed upon with the Customer.

It must include all electrical devices that have a functional relation to the hydraulic assemblies. For larger or more complicated production equipment, the diagrams shall be structured based on function groups.

The valves mounted on plates or in links shall be depicted on the circuit diagrams according to location/position. The pos. no., electrical designation and triggered functions are also to be included.

Upon agreement with the Customer, pipelines and connections shall be depicted in the installation diagram for extensive, large-scale systems.

1.8.8.5 Pneumatic system

1.8.8.5.1 Circuit diagrams/Parts lists [BoM]

Circuit diagrams and BoMs shall be displayed in E-Plan as of version P8 as defined by DIN ISO 1219-2. The version must be agreed upon with the Customer.

All electrical devices must be listed that have a functional relation to the pneumatic assemblies. For larger or more complicated production equipment, the diagrams shall be structured based on function groups.

The valves mounted on plates or in links shall be depicted on the circuit diagrams according to site/position, including the pos. no., electrical designation and triggered functions.

The diagrams must include information about compressed air consumption, connection cross-section, etc.

1.8.8.6 Lubricating technology

1.8.8.6.1 Lubrication circuit diagram/Parts lists [BoM]/Lubrication instructions/Plan with lubricating points

The lubrication diagram includes the following information (E-Plan):

- Lubricating point with designation in the machine/machine system
- Lubricant (medium)
- Lubricating cycle and metered amount (volume).
- Setting for pressure switch/valve
- Capacity and re-fill amount (volume) of lubricant container
- Permissible oil temperature for circulating lubrication
- Performance data of the pump drive.

For linked machines/machine systems, a lubricant manual for the entire system shall be delivered in addition to lubricant instructions for the individual machines.

1.8.8.6.2 Machine lubricant card

Coordinated with Customer.

1.8.8.7 Cooling lubricating technology

1.8.8.7.1 Circuit diagrams/Parts lists [BoM]

Circuit diagrams and BoMs shall be created as defined by DIN ISO 1219-2.

All electrical devices must be listed that have a functional relation to the cooling lubricating technology assemblies. For larger or more complicated production equipment, the diagrams shall be structured based on function groups.

Upon agreement with the Customer, pipelines and connections shall be depicted in the installation diagram for extensive, large-scale systems.

1.8.8.8 Safety of machinery, environmental and fire protection

1.8.8.8.1 EC/EU declaration of conformity/risk assessment

Marking of components with safety functions (*refer to section Work safety, page 16*).

Documents subject to the Pressure Equipment Directive, the AD 2000 regulations and the Ordinance on Industrial Safety and Health are to be submitted at the time of start-up at the latest.

1.8.8.9 Protocols

1.8.8.9.1 Certificates and licenses

These include certificates and licenses such as certificates of origin and software licenses.

1.8.8.9.2 Electric test protocols (additional requirements for Europe)

These include, among other, the electric test report based on DIN EN 60204-1, the test report for insulation resistance, the loop resistance test report for the equipment grounding conductor and the Profibus measurement report, bus measurement report

1.8.8.9.3 Geometric measurement report

The geometric measurement report of the spindle unit shall be delivered. These documents shall be stored in the 08 "Protocols" folder.

1.8.8.9.4 Test reports / Certificates / Overview list

When installing (e.g. pressure vessels, non-contact protective devices, presses and other) equipment requiring inspection, the Contractor must fill out an overview list (Annex 2 Overview list).

Components featuring specific test periods must be mentioned explicitly and discussed.

Necessary test certificates such as documents from certified inspection agencies (e.g. TÜV), seal integrity tests, sound measurement report, shall be included in delivery.

1.8.8.9.4.1 Test reports / Certificates / Overview list (additional requirements for Germany)

Subcontractor documentation, welding certificates and all other documentation which is used to prove compliance with the Federal Water Act, must be stored together in the Protocols register.

1.8.8.10 Instructions for Technical Documentation on Data Carriers

The ZF machine number, followed by the manufacturer's number, shall be entered in the upper-most level; the Customer will assign such numbers.

The files shall be stored in the lowest level of the file structure. The file name must start with the designation in plain language.

For drawings, the file name is designation, drawing number. For parts lists, the file name is designation, drawing number, parts list. Non-integrated images are to be delivered in EDP format (e.g. jpg, png, tiff).

2 Order processing and documentation

2.1 Design release

2.1.1 Supplied drawings

The Contractor must inspect drawings provided by the Customer for each order with regard to correctness, completeness and feasibility in accordance with the contractual agreement. If the Contractor has gained knowledge or realized - thanks to his expertise - any related discrepancies and the necessary changes to address them, the Contractor must notify the Customer about this immediately and cooperate with the Customer on a solution. Changes approved by the Customer in writing must be incorporated.

2.1.2 Inspection and endorsements

Provided that no other agreement has been made, one copy each of the functional plan, the general and final drawings of the machine/machine system, the documentation for electrical engineering, mechanics, hydraulics, pneumatics, lubricating technology, cooling lubricating technology, safety of machinery, environmental and fire protection must be delivered to the Customer for inspection. Enough time must be allowed for changes to be made with the Customer's endorsement without delaying the start of manufacture of the machine/machine system.

The endorsement does not affect the Contractor's contractual obligations.

As a rule, the Customer has a term of at least two weeks for the inspection.

The Customer will provide the Contractor with the design release once the inspection and any design discussions have been completed. The Contractor is responsible for arranging the schedule for this.

2.2 Test run at the Contractor's

2.2.1 General requirements

The machine/machine system test run always takes place at the Contractor's plant according to the contractual agreements or the Customer's specific test run terms and conditions.

The machine/machine system test run at the Contractor's plant does not represent the Customer's final acceptance.

2.2.2 Implementation

The test run at the Contractor's shall take place in the presence of Customer representatives.

A joint test run report (template of ZF Friedrichshafen AG) shall be created at the end of the test run confirming its success, possibly with reserved rights concerning any stated defects (list of defects), or documenting its failure – likewise with a statement of detected defects (list of defects).

Operating instructions and e.g. a declaration of conformity, as well as all necessary pre-operation inspections and their corresponding test certificates and technical documents including data carriers, must be available for the test run, and these are handed over to the Customer's project manager.

2.2.3 Defects

The Contractor must correct any defects detected during the test run by the time the machine/machine system is delivered to the Customer.

Furthermore, reference is expressly made to the "ZF Terms and Conditions of Purchase for Machines and Machine Systems".

2.2.4 Delivery approval

A successful test run at the Contractor's plant is a prerequisite for delivery approval. The Customer shall provide delivery approval to the Contractor by issuing a written confirmation in the test run report.

Once delivery approval has been granted, the Contractor is to agree with the Customer: the delivery date for the machine/machine system and the date when the Contractor's technicians will begin their setup and assembly work.

2.3 Installation and Assembly

2.3.1 General requirements

The machine/machine system shall always be set up and assembled at the Customer's installation site according to the contractual agreements or the Customer's specific setup and assembly terms and conditions. Furthermore, reference is expressly made to the compliance with the latest "ZF Terms and Conditions of Purchase for Machines and Machine Systems".

Vibration-isolated setup is mandatory. This means that vibrations impacting surrounding areas must be minimized and that at least the requirements of the standard are to be observed. The Contractor must provide the Customer with the necessary information regarding this process.

The Contractor must offer or supply the setup elements in accordance with the approved list.

If possible, the machine/machine system is to be set up without being fastened, i.e. no anchoring or doweling.

If it is not possible to set up the machine/machine system without fastening it, the Contractor must agree the type of anchoring to be used for the machine/machine system together with the Customer. Suitably sturdy dowels and anchors are to be used.

2.3.2 Preparation

The Contractor must coordinate the contents and date of the setup and assembly work with the Customer.

The Contractor shall provide the Customer with basic requirements for the setup site, e. g. stiffness, large recess clearances, precision, information on vibration damping, anchoring, stress points, settling tolerances and other basic requirements that the Customer must follow.

The Contractor must become familiar with the local conditions of the setup site in advance. This shall take place at appointed times with the help of the Customer and involve, for example, the possibility of installation, the energy supply, as well as the arrangement and setup of assemblies like switch cabinets, coolant and lubricant systems and hydraulic units.

Before assembly, the Contractor must inspect any safety equipment and protective coatings at the setup site used to collect fluids that are hazardous to water. Defective areas may be closed in only after repairs have been completed. The Contractor must coordinate this with the Customer in each instance.

If hazardous materials and/or work substances are used or processed during the assembly of the machine/machine system, the Contractor must provide the Customer with the name, type, quantity and storage location before assembly begins. The Contractor is responsible for the transport of such substances to and at the machine/machine system setup site.

2.3.2.1 Preparation (additional requirements for Germany)

If any machine/machine system is filled with material hazardous to water such as hydraulic fluids, lubricants, cooling lubricants, etc., the Contractor must prove its technical qualification to the Customer in accordance with § 19 I of the Federal Water Act before starting setup work.

2.3.3 Implementation

Before and during the setup and assembly work, the Customer's safety coordinator and the Contractor must review the schedules and technical safety issues.

2.4 Startup

The 'startup' of the machine/machine system shall always take place at the Customer's installation site according to the contractual agreements or the Customer's specific terms and conditions.

The Contractor is responsible for providing the programming and service devices, tools, resources, measurement and test equipment as well as hoisting devices needed to 'start up', program and service the machine/machine system.

During 'startup', the Contractor is to list all setting parameters. This list is one of the requirements (for the ready-to-use handover) for final acceptance and must include the official date.

2.5 Ready-for-operation

2.5.1 General requirements

The machine/machine system shall always be delivered ready-for-operation at the Customer's setup site according to the contractual agreements or the Customer's specific terms and conditions for ready-for-operation delivery.

Ready-for-operation delivery does not represent final acceptance.

2.5.2 Prerequisites

All defects previously detected in the machine/machine system have been corrected in coordination with the Customer.

The machine/machine system must pass the Customer's technical safety inspection before ready-for-operation delivery can take place.

The Customer's operators are successfully instructed and trained according to the terms and conditions listed in Chapter I.6.

The ready-for-operation delivery must be accompanied by operating instructions and a declaration of conformity as well as all necessary pre-operation inspections, and the corresponding test certificates and technical documents, including data carriers; these are handed over to the Customer's project manager.

2.5.3 Implementation

Ready-for-operation shall be performed in the presence of both Customer and Contractor representatives.

A joint protocol shall be created at the completion of the ready-for-operation delivery confirming a successful ready-for-operation delivery – with all rights reserved concerning any stated defects (list of defects) – or rejecting the ready-for-operation delivery – likewise with a statement of detected defects (list of defects).

2.5.4 Defects

The Contractor must coordinate with the Customer to schedule any corrections of defects discovered during the ready-for-operation delivery process.

If ready-for-operation delivery needs to be repeated and the Customer is not at fault, the Contractor shall pay the Customer's expenses incurred while repeating the ready-for-operation delivery.

Furthermore, reference is expressly made to the "ZF Terms and Conditions of Purchase for Machines and Machine Systems" (amongst other things, liability for defects).

2.6 Test run / Test operation under serial conditions at the customer

The test run/test operation of the machine/machine system at the Customer's site is generally performed under the Customer's volume production operating conditions. During the test run/test operation, the latest version of software and hardware documentation (e.g. technical documents, on-site data carriers, etc.) must always be available to the operator.

If the Contractor needs to modify the PLC program after ready-for-operation delivery, the data carrier containing the program valid at that time is to be picked up beforehand from the Customer's responsible maintenance department. After the modification of the PLC program has been completed, the data carrier containing the changed and updated program must be returned to the responsible maintenance department.

2.7 Acceptance

2.7.1 General Requirements

Final acceptance of the machine/machine system shall always take place at the Customer's installation site according to the contractual agreements or the Customer's specific final acceptance terms and conditions. Furthermore, reference is expressly made to the "ZF Terms and Conditions of Purchase for Machines and Machine Systems".

2.7.2 Prerequisites

All conditions of the machine/machine system agreed to between the partners (requirement specification, negotiation protocol, etc.), especially the agreed upon technical values (quality, cycle time, setup time, technical availability $\geq 98\%$, short-term process capability $cmk \geq 1.67$, long-term process capability $cpk \geq 1.33$, geometric measurements, etc.), are mandatory.

The complete and updated technical documentation is available in the defined formats in accordance with this delivery instruction.

2.7.3 Implementation

The approved tools, clamping devices, clamping device and fixtures are to be used during acceptance. Any changes shall require written confirmation. During the acceptance process, the reference workpieces described in the requirement specification shall be machined.

The same fastening and clamping spots are to be used for holding the workpieces to be machined as those that the Customer will use for the machine/machine system during volume production.

The machine/machine system must have operating temperature at the start of and during acceptance.

Workstation or emissions measurements are to be performed by an independent, licensed institution in coordination with the Customer as part of final acceptance. The Customer shall determine the conditions

under which a measurement can be omitted. In case of non-fulfilment of the requested condition, the Contractor has to bear the costs.

The results of the measurements performed during the acceptance process for hazardous materials and air pollutants must fall below and stay below the current acceptable limits.

A joint final acceptance report shall be created upon completion of the acceptance process confirming final acceptance, possibly with reserved rights concerning any stated defects (list of defects), or withholding final acceptance — likewise with a statement of detected defects (list of defects).

2.7.4 Defects

The Contractor must coordinate with the Customer to schedule any corrections of defects discovered during the acceptance process.

If an acceptance process needs to be repeated and the Customer is not at fault, then the Contractor shall pay the Customer's expenses incurred while repeating the acceptance process.

The Customer may withhold a reasonable sum from the remaining portion of the total price until all defects are corrected or until acceptance has been granted. See also ZF Terms and Conditions of Purchase for Machines, Assembly Technology and Machine Systems.

2.8 Extension of the period of limitation for defects

If the technical availability is less than expected during the last month of the period of limitation for defects and the Customer is not to blame, the warranty period shall be extended automatically by one month, respectively, until the agreed technical availability is provided.

3 Technical Equipment Instructions

3.1 Universally valid

Applies to all technologies listed in chapter 3.

3.1.1 Scope of application

The technical instructions described here apply specifically to the machine/machine system's electrical engineering. They supplement the instructions listed in Chapter I "General Information" of the ZF Technical Delivery Specifications and alongside these, are valid for all ZF plants.

3.1.2 Normative references

As a basic principle, the agreements listed in Chapter I "General Information" regarding normative references apply.

3.1.2.1 Normative references (additional requirements for Europe)

They concern the electrical equipment of machines/machine systems and supplement the valid versions of DIN EN 60204-1 and VDA-LVE.

Observe DIN EN 60204-1 (VDE 0113 Part 1) and DIN EN 50178 (VDE 0160), including the target specifications and recommendations contained therein.

3.1.3 Definitions (additional requirements for Germany)

Definitions, included in the *General Part chapter* have to be adhered to.

3.1.4 General Requirements

3.1.4.1 Selecting the equipment

3.1.4.1.1 Operating material

The Contractor shall select or design all operating material in such a way that it can be connected to the existing local networks - despite any voltage fluctuations and interfering pulses - and is fully functional without any special precautions.

3.1.4.1.2 Approved list for components

Only components and assemblies appearing in the approved list may be used. They must be in their original condition and without any modifications whatsoever when installed. Deviations must be approved in writing by the respective technical department.

3.1.4.2 Electrical engineering system setup and installation

Wiring must comply with the current EMC directive.

Inductive and capacitive interference (e.g. caused by current converters, protective coils, controlled drives, transformers and their power lines, etc.) must not impair the PLC function.

It must be taken into consideration that switch cabinets can be set up in proximity to existing cable routes on site that are unrelated to the machine.

Shielded cables as specified by the manufacturer are to be used for analog signals, interfaces and bus cables.

The installation guidelines of the system control manufacturer are binding.

Make sure the devices are easy to access. The replacement of assemblies and components as well as the removal of covers must be possible without having to disassemble other components. (see also VDE0100-729).

In the case of special machines, 20% space reserves must be available in the switch cabinet at the time of ordering.

3.2 Electrical engineering setup

3.2.1 Electrical supply and network connections

3.2.1.1 Line entry

The Customer will connect the feed line to the switch cabinet. Cable glands or cable fittings, including strain relief, as well as any covers are part of the scope of delivery for the machine/machine system.

3.2.1.2 Power supply

Terminal blocks must be provided for the power supply connection up to 240mm². Pay attention to the clockwise phase sequence! An equipotential bus bar shall be provided and connected to the line-side protective ground conductor.

A 5-line terminal (TN-S system) must always be provided. A connection between N and PE in the machine/machine system is not permitted!

3.2.1.3 Control circuit grounding

Control circuit grounding is only permitted with a disconnect terminal.

3.2.1.4 Main power switch

Every machine/machine system must have a mechanical 3-way lockable main switch.

Door coupling is not permitted; the switch toggle must be fastened to the switch element.

Main switches with a current > 125A form an exception.

3.2.1.5 Supply voltage

In the event of a supply voltage failure, the control unit must turn on automatically when supply voltage is restored so that all configuration parameters are re-set without input from the operator and without triggering the actual machine/machine system (processing/motion) to start.

A failure of the supply voltage must not lead to a loss of data. Furthermore, it has to be ensured that as soon as the supply voltage is back, the systems are able to start up smoothly and that a restart by the operator is possible. If a rechargeable battery or battery is used to keep data, its voltage needs to be monitored and visualized.

3.2.1.6 Malfunctions

The program must restart properly after voltage sags and failures or any system disruptions. With the control unit, it must be possible to bring the production equipment ahead in the cycle or into home position.

3.2.1.7 Startup routines

The machine/machine system's technical documentation must include special startup routines after a general reset of the system.

3.2.1.8 Plug power supplies

Plug power supplies are not permitted.

If the application is required (e.g. printer, hand scanner) this must be agreed upon with the project manager.

3.2.2 Protection against electric shock (additional requirements for Europe)

The conditions defined in DIN EN 60204-1 apply.

3.2.3 Equipment protection

3.2.3.1 Overcurrent protection

3.2.3.1.1 Overload and short-circuit protection

Up to 32A, automatic circuit breakers are required (without fuse) to protect against overload and short circuit.

Three-pole automatic circuit breakers are required in general three-phase circuits.

Protective motor switches are required for motor electric circuits up to 100A.

Above a current intensity of 35A, NH circuit breakers are to be provided.

3.2.3.1.2 Switch response

The operator panel must display the response of protective motor switches and miniature circuit breakers. For more than 5 motors and/or miniature circuit breakers, the responses must be displayed individually or in groups including the location.

3.2.3.1.3 Special motors

A temperature monitor is required in the winding for motors used for heavy starting, for a 5x per hour or higher switching frequency or for converter feed.

3.2.3.1.4 Recovery

The Contractor must ensure that no incorrect recovery of harmonics occurs in the network.

3.2.3.1.5 Pulse circuits

Pulse circuits must be designed with semiconductor (e.g. washing machine heating). Safety must remain guaranteed.

For example, it must be possible to securely switch off the heating of washing machines via the control voltage. For this purpose, an additional contactor that is adapted to the nominal output has to be included in the load circuit of the heating. This contactor should only switch off the heating redundantly in case of "control voltage off", "excess temperature" or "Emergency STOP".

3.2.4 Equipotential Bonding / Screening

Screening of signal lines must take place near the device itself and may not be used for equipotential bonding.

A topology plan for equipotential bonding also needs to be supplied.

Toothed disks, snap rings, contact disks with cutting teeth, etc. must not be used as connectors. Also, the earth lug must not be mechanically damaged by toothed washers, snap rings, etc.

Corrosion-prone areas must be treated with a suitable protective agent.

Equipotential bonding must converge in a central location and be designed in accordance with the EMC guideline.

Equipotential bonding must be designed in accordance with the relevant standards. When doing so, high-frequency interference signals/currents caused by converters and nonlinear consumers must be observed. Depending on the currents' frequency and to account for the skin effect, highly flexible lines/conduction bands may need to be used. All connecting points must be free of lacquer. Threads must not be used as conductors.

3.2.5 Control circuits and control functions

3.2.5.1 Control voltage

The control voltage for PLC, initiators, photoelectric barriers, valves, solenoids, etc., must be 24V DC.

3.2.5.2 Operating modes and functions

The Customer shall be consulted about operating modes and functions (e.g.: manual, stop at cycle end and idling "all units in home position").

3.2.5.3 EMERGENCY STOP SWITCH / Error

3.2.5.3.1 Safety equipment harmonization

The Customer shall be consulted about all system safety equipment and the boundaries of the "EMERGENCY STOP" circuits between individual system parts. In the case of interlinked systems/machines, the supplier must provide an EMERGENCY STOP concept and must harmonize it with the Customer.

3.2.5.4 Safe state

After a malfunction, the machine/machine system must shut down in a defined condition (if at all possible from a technical-safety perspective).

3.2.6 Operator interface and control equipment mounted on the machine

3.2.6.1 Status and error displays

Signal lights must display the operating status in plain view for machines/machine systems, machining cells, linked systems and assembly units:

- Red (flashing light):
Malfunction indication (e.g. machine standstill due to electrical or mechanical malfunction, "EMERGENCY STOP" activation)
- Yellow (steady light):
Machine standstill due to unfulfilled start conditions (e.g. setup operation, maintenance, missing workpieces, tool replacement)
- Yellow (flashing light):
Warning, machine shut-down impending due to e.g. missing workpieces in the feed, minimum stock reached
- Green (steady light):
Machine running in automatic mode, normal operation
- Green (flashing light):
Machine/machine system is in automatic mode and the start condition is satisfied.

The sequence of colors from top to bottom is red – yellow – green.

When using smart lights, a segmentation is also necessary.

3.2.6.2 Distinction

A clear distinction must be made between fault messages and operating messages.

3.2.6.3 Reporting switching states

The switching states of the safety switching devices used ("EMERGENCY STOP", guard doors, two-hand start, ...) shall be reported separately to the PLC via its signaling contact. If multiple commands are to be assigned to a safety switching device, they are to be sent back individually to the PLC in addition via auxiliary contacts and displayed in the operator panel.

ProDiag is to be used as diagnostic software. After consultation with the Customer, an alternative corresponding to the same function can be used.

3.2.7 Electronic equipment/Control interfaces

In general, topics regarding security, hardware, network and software must be agreed with the Production IT department before presenting the offer.

3.2.7.1 Control design

3.2.7.1.1 Solutions for Powertrain – List of components

The control concept "Solutions for Powertrain" (Siemens) shall be used throughout.

Deviations from the control concept are only allowed in exceptional cases and must be agreed upon with and approved by the Customer and the Maintenance dept..

More information (Internet access) can be found on the SIEMENS Extranet. Access is granted by SIEMENS.

3.2.7.1.2 Software

The Contractor must coordinate the software structure (PLC, NC, robot program, etc.) with the Customer and the Maintenance dept.

3.2.7.1.3 Visual display

Visual display is to be provided for every control unit. This must be agreed with the Customer and the maintenance department.

3.2.7.1.4 Implementation of functions

Functions that are not always executed manually must be implemented within the visual display.

Functions that are always executed manually shall be implemented using separate pushbuttons.

3.2.7.1.5 Selection of operating system

When selecting the operating systems, the approved list for components/equipment regulation is binding.

The operating system shall use the language of the operator.

The license number in each case shall be attached to the unit so that it is visible and permanent.

3.2.7.1.6 Use of control unit

The use of a pure PC-based control unit (e.g. installation of soft PLC in IPC, slot PLC, etc.) is not permitted.

3.2.7.2 Electronic equipment/control units

The input and output supply circuits must be divided into groups and selectively protected so that a short circuit will not lead to CPU failure.

AC 230 V assemblies and relay cards are not permitted.

Only one consumer may be assigned to each output and only one actuator to each input.

With decentralized peripheral construction of the I/O levels, the addressing shall be provided in associated blocks with suitable reserve areas (min. 10%) (e.g. E 0.0-0.7, continued with E1.0-1-7).

When the control unit is "Off," the CPU's power supply must remain.

3.2.7.3 Software

In the case of deviations from the ZF standard (see approved list), the software to modify, expand, reload and archive the programmable system or systems is part of the machine/machine system's scope of delivery.

Any necessary licenses and documentation that is required for licensing must be included.

Locking the PLC modules using know-how protection is not permitted.

For CNC machines, the project configuration software (only Step 7 and/or S7-Graph) shall be installed on the control unit and the license included.

3.2.7.4 Control stations/Control panels

3.2.7.4.1 Program/Programming

The program of a control panel (e.g. Simatic OPs) must be available in the source code.

Standard program modules (generally from Siemens) must be used for programming.

3.2.7.4.2 Range pointers for the OP interface parameterization

Range pointers should preferably be stored as data blocks.

3.2.7.4.3 Superuser

A "Superuser" shall retain the manufacturer's standard password or standard default setting.

ZF is also entitled to change the password.

3.2.7.4.4 Help texts

If additional information is needed to operate the machine, the pertinent help files must be provided for.

3.2.7.4.5 Setup data

The administration of the setup data/tool-specific data of the machine/machine system must always be agreed on with the project manager. Possible variations are, e.g.:

- Administration in the PLC
- Administration in recipe
- Administration in NC program
- Administration in SCADA/MES system
- ...

3.2.7.4.6 Icons

The Siemens standard must generally be used for any icons. When icons are used, they shall be additionally executed in text form, e.g. via the Info button.

3.2.7.5 Programming devices

Additional programming devices, switch-on assemblies, manual programming modules as well as interface cables which are required for operating and maintaining the machine/machine system must be included in the scope of supply or otherwise offered separately (only applies in the case of a deviation from the ZF standard).

It must be possible to connect a programming device at any time without disconnecting the power lines to the PLC and control panel. This must not impact the function of the control unit.

3.2.7.6 Interfaces

The interfaces and interface signals for integrated and peripheral equipment (e.g. industrial robots, conveyor systems, screwdriver control units, cooling lubricant systems, chip removal, etc.) shall be coordinated among the individual subcontractors or device and system manufacturers, respectively, and automatically presented to the Customer for approval. Interface signals must be implemented in 24V DC and potential-free or in BUS technology after consultation. The interface signals must be visualized including their status. The signal designations must be consistent.

3.2.7.7 Data transmission / Service interface

The interfaces must be designed to be on the outside of the control panel or operating location and have an attached cover.

A connection for the programming device shall be provided in the switch cabinet. In the case of spatially expanded machines/machine systems, multiple connecting points must be provided. Interface connections on the CPU are to be designed with double contacts (MPI and Profibus).

3.2.7.8 Coupling several control units and systems

Bus systems shall be taken from the approved list. Coupling several control units needs to be agreed in advance with the Customer and approved in writing.

3.2.7.9 Profibus

Profibus is not released for new systems.

3.2.7.9.1 Bus topology

The circuit diagram shall contain the bus topology with the following information in a clear format:

- Slave address
- wire lengths running between the individual bus participants
- clear wire designations
- installation location of the bus participants in the system (block diagram)
- the bus segment must be recognizable.

3.2.7.9.2 Inspection documents

The inspection documents for the following parameters must be issued:

- The real cable lengths (min. 1m, max. 100m) and the impedance values of a Profibus segment.
- The transmitting level of all bus participants as a bar chart (minimum 2.5V and no signal distortions).
- The bus cycle time (average, max/min) and the number of error messages per hour (< 30).

3.2.7.10 ProfiNet

The design of ProfiNet shall be coordinated with the Customer and documented.

ProfiNet must be disconnected from the ZF production network.

Communication between controls may only run via communication processors (CPs) (no direct routing of the interfaces).

If a connection to the ZF production network is required, this must be implemented using suitable firewalls.

ZF specifications for PROFINET networks

- The guidelines of the Profibus User Organization (PNO) for
 - planning,
 - installation and
 - commissioning must be observed as a basic principle.
- Only use certified PROFINET devices. It must be possible to diagnose the devices and they must at least correspond to PROFINET Conformance Class B (CC-B).
- In general, PROFINET-IO communication must not take place via WiFi. In exceptional cases (e.g. application of Mobile Panels), a consultation with the Customer, the Maintenance dept. and ZF IT has to take place beforehand in order to receive their approval.
- PROFIsafe devices must have both PROFINET and PROFIsafe certification.
- For all plug connectors and cables, only use PROFINET components for which a manufacturer's declaration of conformity for PROFINET standards is available.
- Industry-grade cables are to be chosen in accordance with external impacts (e.g. heat, oil, etc.) as well as the use case (e.g. cable trailing device).
- Furthermore, use PROFINET cables in green color and required length. Avoid excessive reserve loops of more than 50 cm.
- Only use managed switches of at least CC-B (in addition, with PROFINET "Quality of service" (QoS) functionality support (IEEE 802.1q / p)) and port mirroring.
- The number of the removeable connections within an end-to-end link must not exceed a maximum of 6 cable connectors. Do not exceed a cable length of 100m between the participants!
- Observe the PROFINET Installation Guideline when routing the PROFINET cables. Document order no.: 8.071. You will find further information regarding minimum distances in IEC 61784-5-3 or EN 50174-2.
- In general, copper is to be preferred, rather than using optical fiber. The use of optical fiber is to be agreed beforehand with the expert department
- The devices and plugs are to be selected according to the required IP rating.
- A network load determination (measurement) is to be carried out.
 - The network load generated by PROFINET must not exceed the 50% limit in the controller hubs.
 - The upper limit value for network load of the cyclic real-time communication per port is max. 30%.
- Bigger data transfer (e.g. image data, data protection, data streams, etc.) within the standard Ethernet communication (not real-time) has to be realized outside the PROFINET network (e.g. separate network interface). If this is not possible, data communication of these participants has to take place directly via a switch (star topology) in the first hierarchy level. This data transfer must not be conducted via a line topology.
- Example topology for the transfer of bigger data volumes (here: between camera and server)

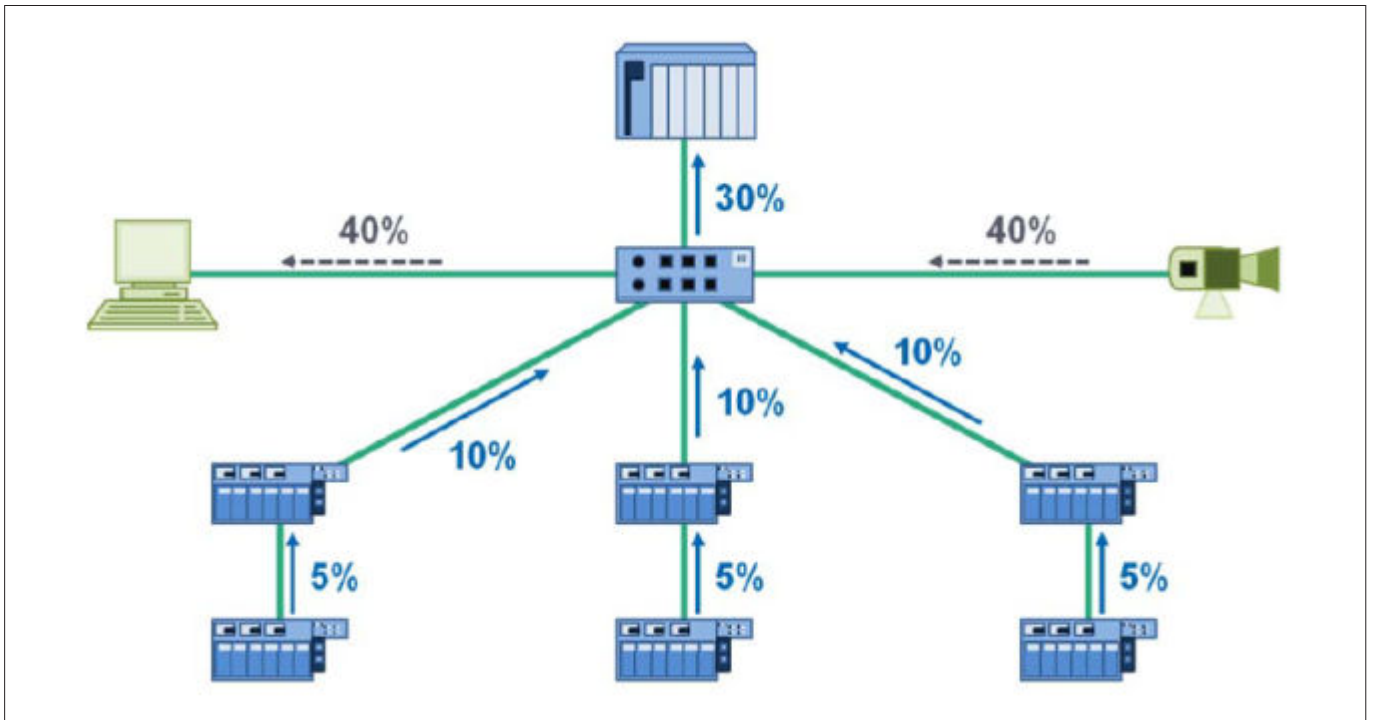

Fig. 1

- It has to be ensured that there is no communication in the network that is of equal or higher priority than PROFINET (VoIP, VLAN,...). (Danger of priority conflicts between PROFINET and standard Ethernet communication)
- A tree/star topology is to be preferred. With a line topology, consider the max. line depth and the update time (update time 1ms / max. line depth 7). See PNO planning guideline.
- Definition of the line depth (here: maximum line depth of 9):

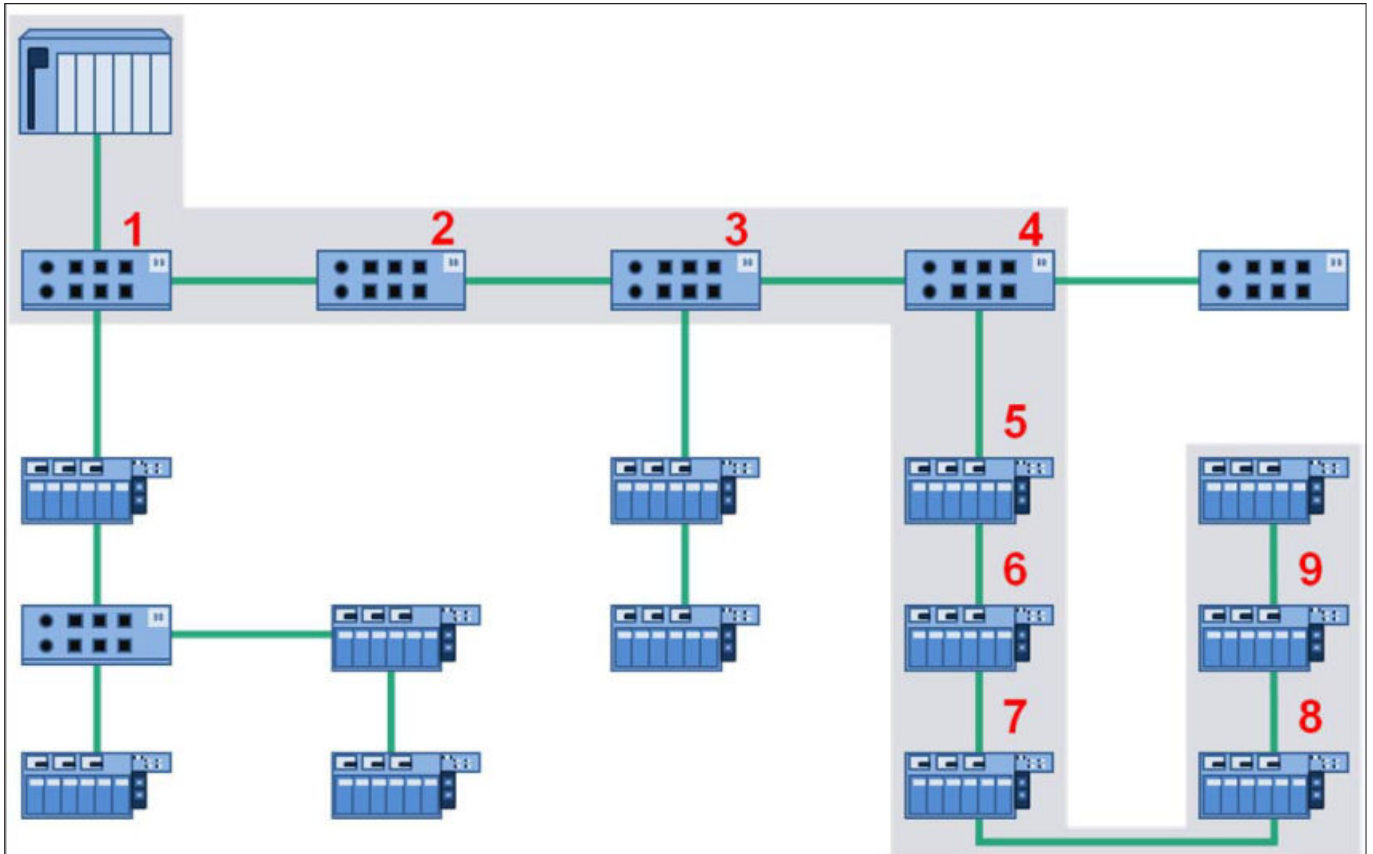

Fig. 2

- The connection of the automation system to the Master Plant Network must always be agreed with the Customer's IT department. In general, PROFINET is to be uncoupled from the plant network. If communication has to take place between the production network and PROFINET, it has to be realized via a suitable hardware firewall with NAT functionality (see TDS approval list).
- Network gateway from Profinet to ZF production network:

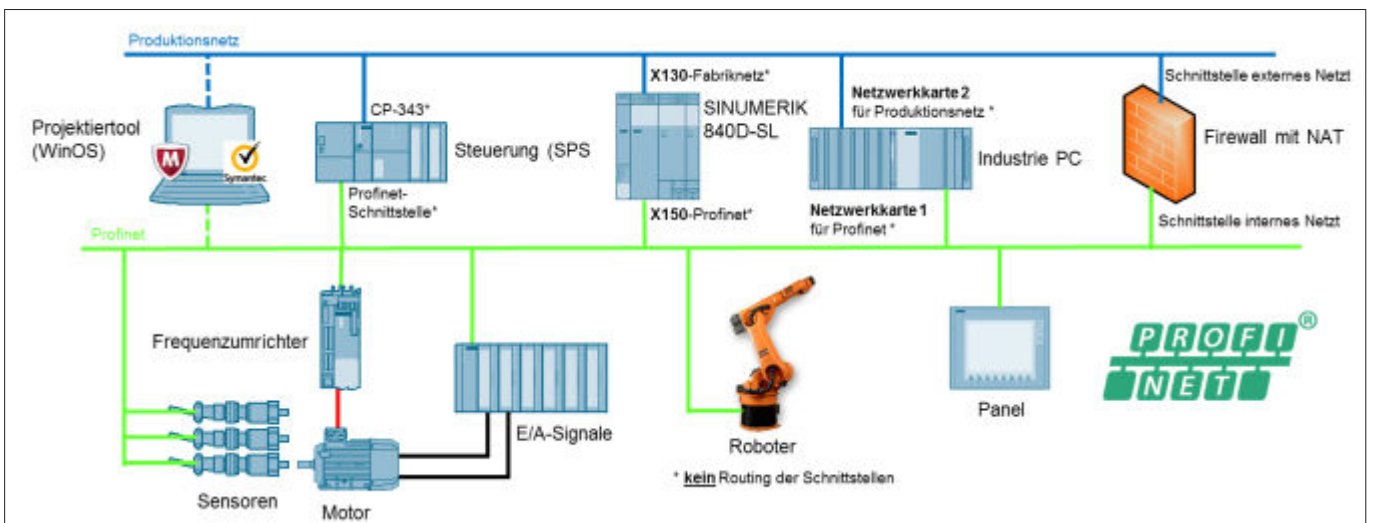

Fig. 3

- During machine acceptance, a standardized firmware state for each device type within the system has to be guaranteed.

- Every star hub has to provide a port for diagnosis.
- As a basic principle, the PROFINET network must include a programming interface that is accessible from the outside.
- The IP address range of the individual PROFINET network has to be agreed on with the Maintenance and Planning departments. In general, a Class C network (network mask: 255.255.255.0) has to be used.

The individual device types of a segment are placed in different address rooms (the first three address blocks are exemplary):

- Gateway: XXX.YYY.ZZZ.1
- PN IO controller: XXX.YYY.ZZZ.10 to XXX.YYY.ZZZ.19
- Switches: XXX.YYY.ZZZ.20 to XXX.YYY.ZZZ.49
- PN IO devices: XXX.YYY.ZZZ.50 to XXX.YYY.ZZZ.229
- Reserve: XXX.YYY.ZZZ.230 to XXX.YYY.ZZZ.239
- Diagnosis/PGs: XXX.YYY.ZZZ.240 to XXX.YYY.ZZZ.254
- The PROFINET device name should be structured as follows:
Equipment designation+device type. The following designations for device types are to be used:
 - "cpu" PROFINET controller
 - "swi" Switch
 - "io" I/O devices (PN IO Device)
 - "drv" Drives
 - "hmi" Panels/HMI
 - "cam" Camera
 - "rout" Router
 - "sens" Sensors
 - "scr" screwdriver
 - Example: 1-600-A1-cpu
- For the controls of the S7-300/S7-400 generation and project planning with SIMATIC Manager, a network overview with the Siemens standard images (diagnosis package PNIODiag / FB126) has to be available on the visualization of the control (e.g. to recognize the failure of a device).
- For controls of the S7-1500 generation and project planning with the TIA portal, the Profinet-IO diagnosis is to be realized in the user program. In this case, a system-wide diagnosis has to be conducted in the form of a system overview and a detailed device view. Further information and sample project planning can be found here: <http://support.automation.siemens.com/WW/view/de/98210758>

3.2.7.10.1 Documentation and acceptance

The PROFINET of the machine/machine system is to be documented:

- A system overview of the automation plan with PROFINET network participant, IP addresses, transfer distances and cable lengths in the E-Plan.
A network structure plan (MS Visio), an IP address list (Excel) and a communication plan (Excel). A template will be provided.

The suitable GSDML files for all devices are to be supplied separately during the handover. Storage on the "Doku CD" as a ZIP file (contains all GSDML files of the system) under the ZF file structure: "\01 Elektrotechnik\02 PLC\GSDML.zip".

3.2.7.11 IO Link

The communication between control unit and IO Link Master or Device should take place in accordance with a standardized principle.

The following mandatory determinations were made:

- The IO Link Master at least has the version state 1.1.
- The IO Link Device has least one functional class of the Smart Sensor profile.
- One of the following data storage functions is provided.
 - Decentralized data storage in the Master (parameter server)
 - Central data storage in the control unit
- A validation of each used Master port is carried out. Here, the compatibility mode is to be chosen.
- Relevant IO Link data (process, parameter, diagnosis data) should be available in one Master data module in the control unit.
- All IO Link data which are stored in the control unit should be accessible via an HMI device.
- The Master data module has a generic setup for all ports.

3.2.7.12 Network connection to the ZF production network

In general, the submission of offers must be coordinated with the Production IT department on the topics of security, hardware, networking and software.

Only the IP protocol may be used as the network protocol.

Routing takes place exclusively via the Customer's own network components. Access via modem, ISDN, GSM, UMTS and DSL is not permitted. The same applies to wireless LANs that have not been approved by the Customer's IT departments. Only network access authorized by ZF is permitted. Remote access can only be implemented via the ZF network.

In the case of an Ethernet network, the machine/machine system must be documented using the Microsoft Visio and E-Plan documentation tools. For this, at least one network structure plan, an IP address list and a communication plan must be created. A sample illustration is provided by the location's Production IT.

The Customer will provide an Ethernet connection.

The OEM must ensure that the machine PC and the applications installed on it are designed for operation with the virus scanner and the "Application Control" whitelisting software.

Before being connected to the ZF production network for the first time, the Contractor must ensure that the entire system is free of malware and provide evidence to the Customer.

In general, the Contractor must ensure the freedom from malware, even in the case of non-networked machines and systems, and provide evidence to the Customer.

Before the Customer connects the system/machine to the ZF production network, the Customer carries out another malware check.

The Contractor only backs up data after the Customer has checked the malware.

In general, the Contractor must ensure that the clients, programming devices and storage media used at ZF are virus-free at all times.

The Customer reserves the right to check this at any time.

It must be avoided that the entire system sources out or swaps applications or parts thereof.

The main memory is to be designed accordingly, a reserve of 10% of the hardware RAM is to be kept.

Adjustments (e.g. exclusion of individual file types from virus scanner monitoring) can be configured in the virus scanner if necessary. ZF must be informed of these adjustment requests before the machine is put into operation.

The following types of network connections are permitted:

The type of network connection required is specified by ZF. Please contact the responsible ZF planning department and the location's Production IT:

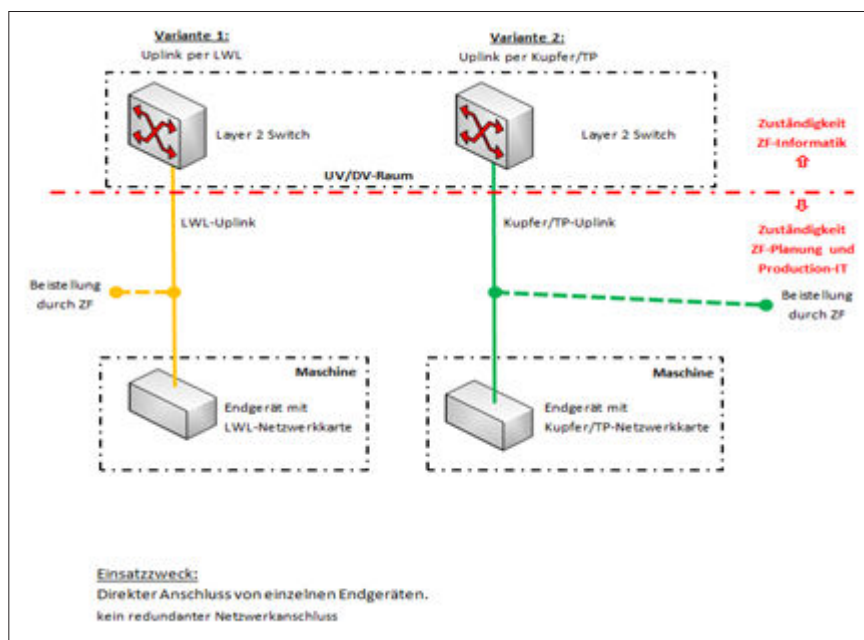

Fig. 4 Connection type M1

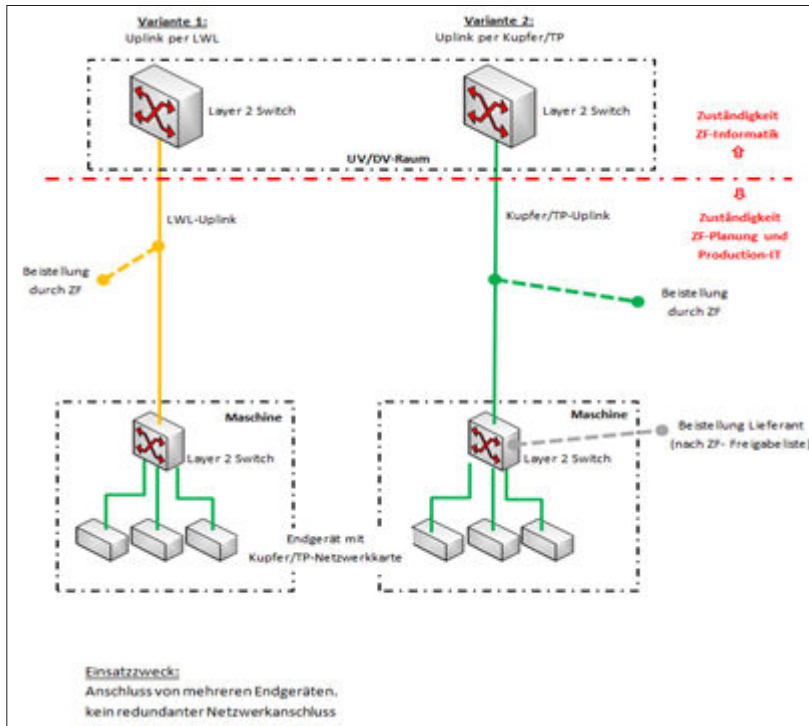

Fig. 5 Connection type M2

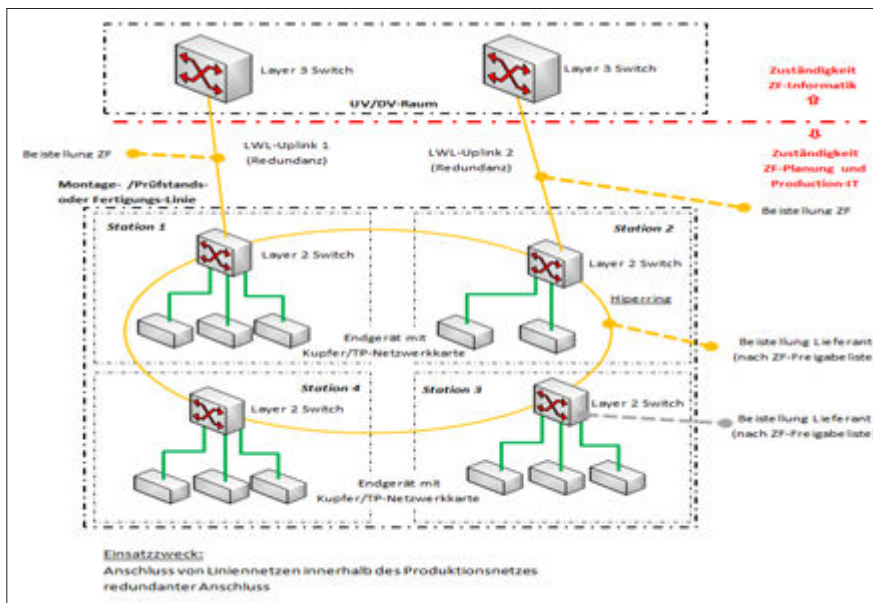

Fig. 6 Connection type M3

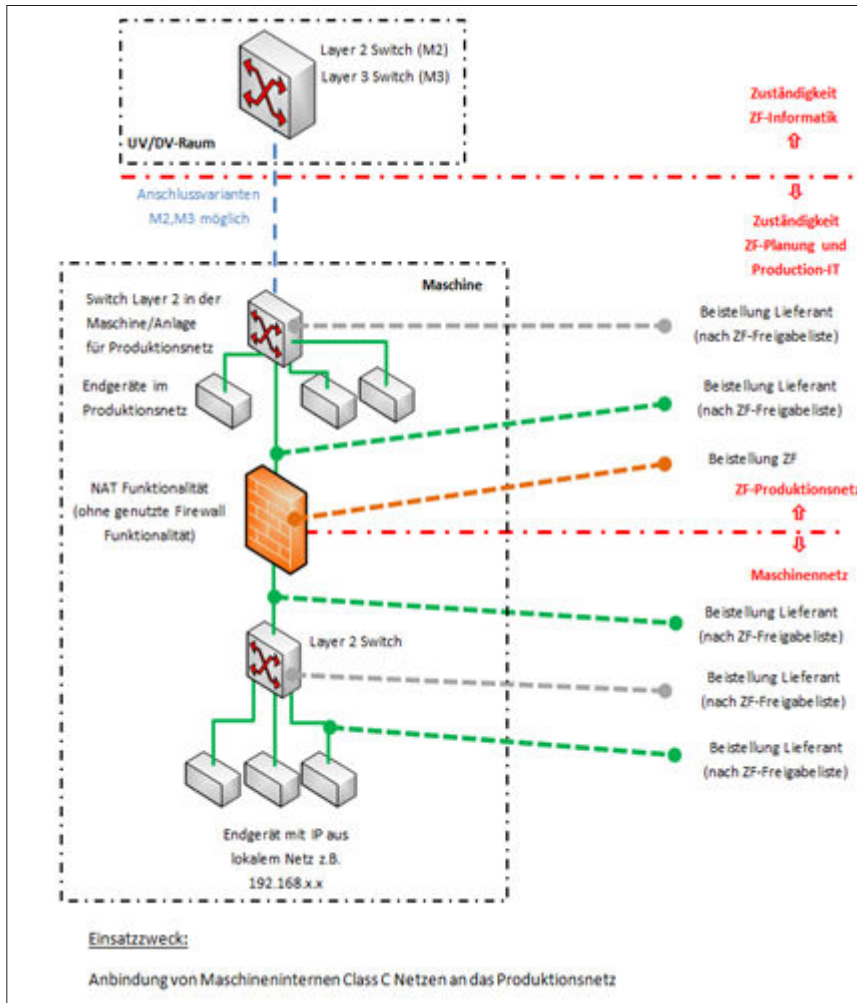

Fig. 7 Connection type M6 / Network transition ZF Production network to Profinet

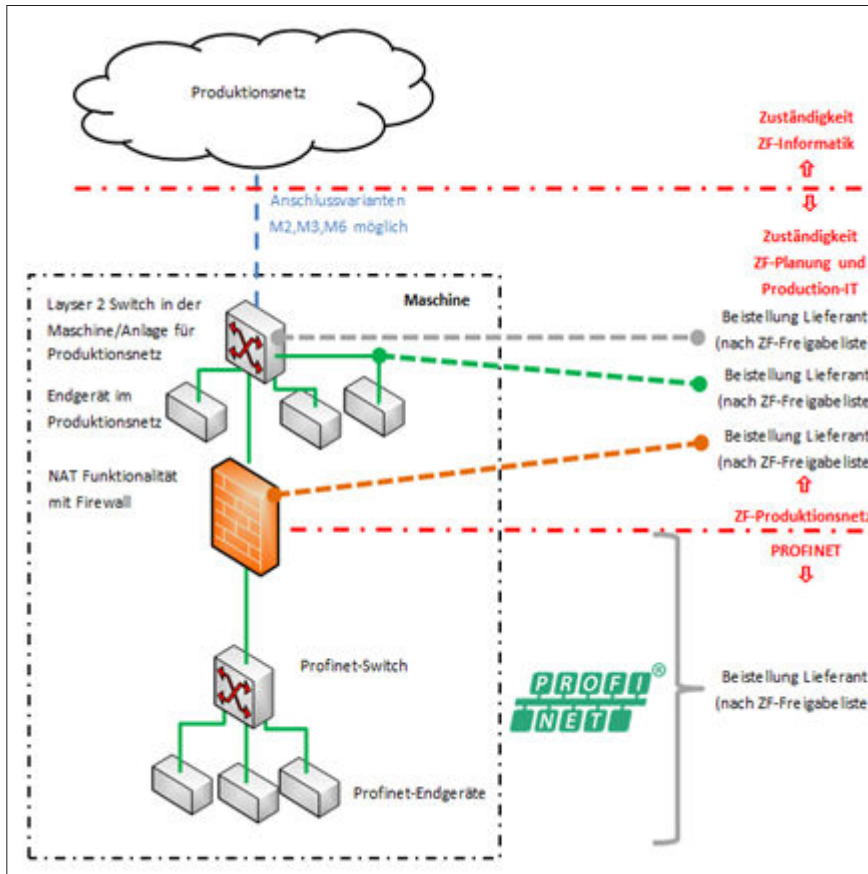

Fig. 8 Network transfer from ZF Production network to ProfiNet

3.2.7.12.1 Specifications for the operation of machine PCs in the ZF production network

UEFI/BIOS password protection by the Contractor (supplier) is not allowed.

Only the following operating systems are released in the ZF production network:

- Windows 10 Enterprise (64bit) LTSB/LTSC (Long-Term Servicing Branch/Long-Term Servicing Channel)
- Windows 10 Enterprise (64 bit) IOT LTSB/LTSC (Long-Term Servicing Branch/Long-Term Servicing Channel)

Other operating systems need a special release by Production IT.

The OEM has to ensure that only these operating systems with the respectively latest patch level are used on the machine PCs.

All machine PCs are preferably equipped with the Whitelisting software "Application Control" (McAfee company) or with the virus scanner (Symantec Endpoint Protection, version to be agreed).

The Customer will provide the necessary client or server licenses and will provide support for updating the antivirus software.

- All screensavers are to be deactivated on the machine PCs.
- Sleep (hibernating) mode is to be deactivated on the machine PCs.

- The machine programs (NC programs, measuring programs....) are to be filed in a central data directory on the machine PC. The directory is to be agreed upon with the location's Production IT.

A machine-internal network is to be separated physically from the ZF production network. Machine PCs that communicate in both networks (machine-internal network and ZF production network) must be equipped with two network interface controllers.

Machine PCs must be technically designed in a way that they can be included in the ZF production network domain (xxxPROD, xxx=ZF-internal location abbreviation) and be operated there.

The OEM has to ensure that the system can load all required information into the existing main storage (RAM) of the machine PC at any time.

It must be possible to update the operating systems and applications at regular intervals according to the latest security requirements.

The functions of the machines/machine systems must not be affected by the security check during operation.

3.2.7.13 Data connection to superordinate IT systems

Before the project planning for the machine system, there has to be a consultation with the Customer's IT, machine planning, and Production IT departments.

Data connection and data exchange have to be agreed on with the Customer before issuing the offer!

3.2.7.14 Remote diagnosis

As a general rule, the connection is established by an employee of the Customer who connects to the machine first and then sets up a web conference with the technician at the manufacturer's site and grants remote access.

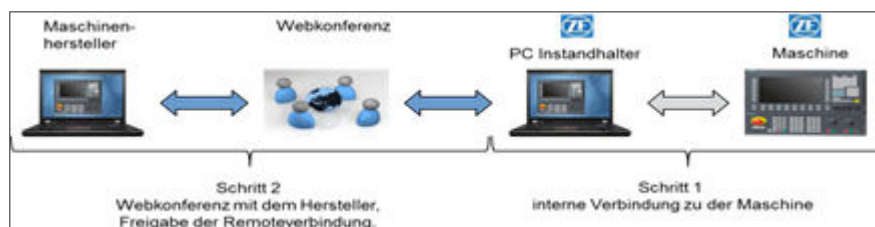

Fig. 9 Remote diagnosis

Manufacturer-specific remote maintenance solutions (e.g. VPN, UMTS USB devices, WiFi Access Points, ...) are not allowed.

3.2.7.14.1 Network connection of the SINUMERIK 840D SL

The SINUMERIK 840D Solution Line must be connected to the ZF production network as shown below. This creates a separation between the internal machine network and the ZF production network.

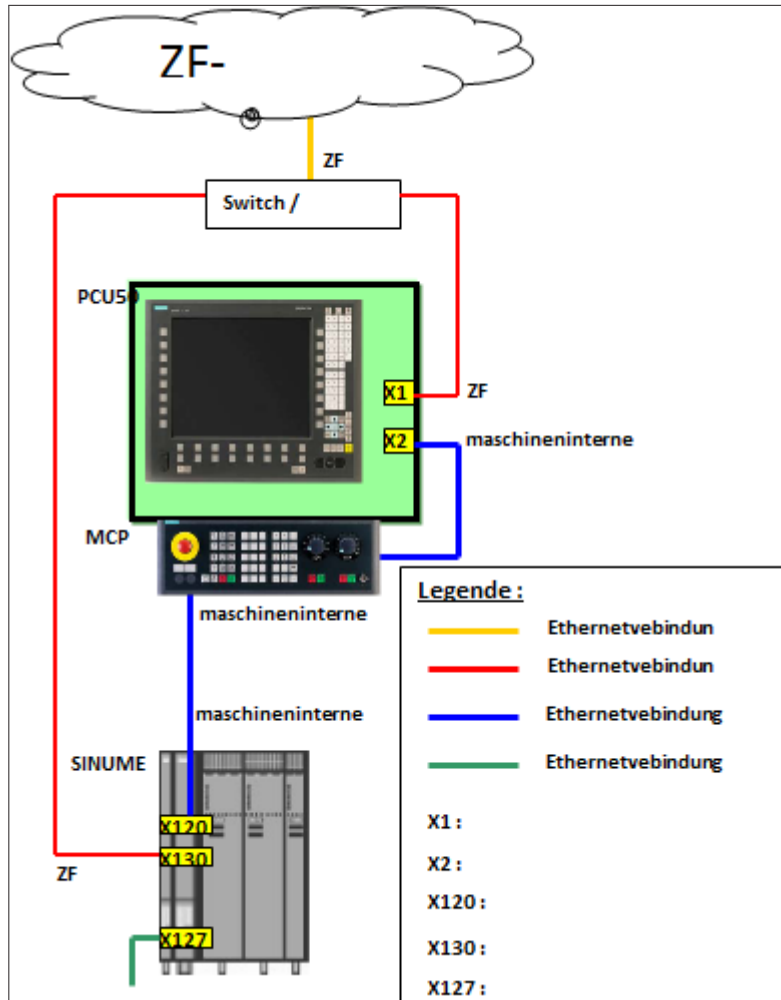

Fig. 10 Data interface for SINUMERIK systems

Recording of machine status/quantities:

- linked operation total (standalone machine) [VKGes]
Address: DB59.DBX86.0
- linked operation standalone machine (master control) [VK]
Address: DB59.DBX86.1
Notification of the performed selection of the automatic production operation (linked or automatic operation). Further details Transline manual, software guide chapter 6.4 linked operation.
- Start actuated (StaB)
Address: DB59.DBX87.0
Report of the started operating mode. Further details Transline manual, software guide (currently valid version) Chapter 5.6 "Start function" and Chapter 6.4 "Linked operation".
- Machine off (input off) (MA)
Address: DB59.DBX87.7

Notification of the switched off machine. In the switched off state, no other notifications or malfunctions are necessary. Further details Transline manual, software guide (currently valid version) Chapter 5.8 "Machine off".

- Driving without part (option) (FOT)
Address: DB59.DBX89.2
Report on the optional cycle type "Driving without part".
- gen. technical malfunction (standalone machine) (Sto)
Address: DB59.DBX88.2
- Malfunction entire machine (master control) (StoGes)
Address: DB59.DBX88.5
Collective signal of the technical malfunctions with machine standstill
- Outlet occupied (AB)
Address: DB59.DBX96.0
Notification of an organizational machine standstill by an occupied outlet or because of workpiece not removed.
- No part in the inlet (KTE)
Address: DB59.DBX96.1
Notification of an organizational machine standstill due to workpiece shortage or because loading did not take place.
- Shortage of feed parts (Tm)
Address: DB59.DBX96.2
Notification of an organizational machine standstill due to material shortage.
- Unit counter:
- Overall unit counter
Address: DB59.DBD1006

3.2.7.14.2 Workpiece and tool data acquisition for Sinumerik controls

If a machine has to be connected to the ZF workpiece/ tool data acquisition system (retraceability system), the system setup has to be agreed upon with the responsible IT department.

If a machine is not connected to the ZF workpiece/tool data acquisition system (retraceability system), DB14/15 is to be kept clear in order to guarantee the possibility to retrofit the retraceability system.

3.2.7.14.3 Serial connection of hand scanners to S7 controls

Serial hand scanners and cameras must be connected to the S7 control via RS232 assemblies. The following regulations apply specifically:

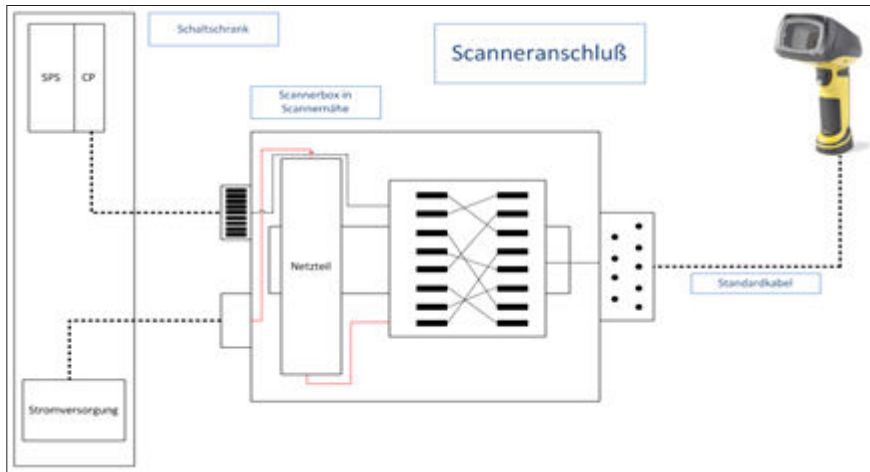

Fig. 11 Serial connection of hand scanners to S7 controls

The power of the scanner is generally supplied via the D-Sub plug.

Standard scanner lines are to be used.

The individual pins of the D-Sub plug must be led separately to a terminal block.

It has to be ensured that the power is supplied "close to the scanner" (max. cable length: 10m) For this, a scanner box with a top-hat rail power supply is to be provided. At the input end, the scanner box must be supplied with 24V DC or 230V AC. The setup of the scanner box is to be requested from the responsible planning department. The length of the RS232 signal cable depends on the selected baud rate.

The following scanner parameters shall be used:

- Baud rate: 9600 BPS
- 8 data bits
- 1 stop bit
- No parity (N)
- RTS/CTS off

At a baud rate of 9600 BPS, the length of the RS232 signal cable must not exceed 152m.

An industry-grade cable is to be used as an RS232 signal cable.

3.2.8 Switching devices: layout, setup and housing

3.2.8.1 General requirements

3.2.8.1.1 Space for buttons and sensors

Space for at least 2 pushbuttons or indicator lights shall be provided. The holes required for this must be prepared and covered.

3.2.8.1.2 Component protection

All machine/machine system electrical components shall be assembled and protected such that they cannot be damaged or triggered in the event that they are stepped on.

3.2.8.1.3 Standard locking

The standard locking method is a two-way key bit.

3.2.8.1.4 Installation spaces for electrical components

The installation space for electrical components (terminal boxes, panels, etc.) generally requires an IP 54 rating, a hinge and a two-way key bit standard locking system. An inspection window shall be provided for I/O assemblies.

Only use a two-way key bit as standard locking method for installation spaces for electrical equipment.

For I/O assemblies in decentralized switch cabinets / terminal boxes, an inspection window shall be provided.

3.2.8.2 Installation and setup

3.2.8.2.1 Multilayer installation

Devices and panels may not be multi-layered in the switch cabinet.

3.2.8.2.2 Swing frame

Swing frames are only permitted if the opening angle is greater than 110° and if it is ensured that the unanchored switch cabinet does not tip over when the frame swings out.

3.2.8.2.3 Front plate

The front plate (of terminal boxes and panels) must swivel and have a catch if there are more than 6 command and message devices.

The devices shall be mounted on the front plate (fastened in front with rear connection). The IP rating of the electrical installation space must not be reduced by installation devices.

3.2.8.2.4 Circuit diagram bag

A sufficiently dimensioned and bolted/riveted circuit diagram bag shall be provided in metal construction for storing the circuit diagram.

3.2.8.3 Switch cabinet cooling

3.2.8.3.1 Temperature

The switch cabinet temperature above control/drive components and control panels may not exceed 40°C. A constant ambient temperature in the hall of 45°C can be expected; possible temperature peaks and location-specific conditions (altitude, impact of the sun's radiation etc.) are to be considered.

Only cooling units with temperature control are permitted for cooling.

When the switch cabinet doors are opened, the switch cabinet cooling system must be interrupted by a door switch.

Filter fans are not permitted.

3.2.8.3.2 Venting condensation

Condensation must be vented to the outside of the switch cabinet and removed or collected using a sufficiently sized device.

3.2.8.3.3 Top-mounted cooling

The Customer shall be consulted about the use of a top-mounted cooling unit and approve it in writing.

3.2.8.3.4 Temperature monitoring

The temperatures in the switch cabinet and the control panel must be monitored and displayed as a fault message if the permissible temperature is exceeded (40°C); the maximum value shall never exceed 45°C.

Malfunctions in cooling units must be monitored and reported to the central control unit.

3.2.8.3.5 Heat requirement calculation

The heat requirement must be calculated to determine the required size of the cooling devices for the electrical installation space (e.g. switch cabinet, etc.) and then entered in the machine/machine system's technical documentation.

Cooling units with more than 3kg of refrigerant are to be listed and documented under the category "equipment requiring inspection". The use of such cooling units shall be coordinated with the Customer.

3.2.8.4 Signals ($I < 10 \text{ mA}$)

Signals with amperage smaller than 10 mA must be transmitted contactless.

3.2.9 Conductors, cables and wiring

3.2.9.1 Color coding

Circuits that are not switched off (external voltage) by the main switch must be labeled in orange in the entire circuit (wire or protective tubing).

Power lines and cables that are tapped before the main switch (continuous voltage) must be marked in orange in the entire route (wire or protective tubing).

Short-circuit proof wires must be used between the main switch and the first fuse if the conductor's cross-sectional size does not match the rated amperages of the fuse.

3.2.9.2 Alignment of wiring

Data, bus and measurement lines must be routed according to the component manufacturer's installation guidelines.

3.2.9.3 Multiple terminals

Sensors can be connected via initiating/sensing terminals; the use of two-tier terminals and multiple terminals is not permitted. Any deviations must be submitted in writing to and discussed with the Customer.

3.2.9.4 Multiple assignment of terminals/ T distributor and Y distributor

The use of T distributors is only permitted if the signal assignment is clear. Duplicating an input/output or mapping logic with T distributors is not permitted. Only one consumer may be assigned to each output and only one actuator to each input.

3.2.10 Wiring technology

3.2.10.1 Wiring inside housings

Wires to devices on swing frames or for door assembly must have protective flexible tubing.

The switch cabinet wiring must be laid in cable ducts.

If wire-end ferrules are used, they must feature plastic protective shrouds.

3.2.10.2 Wiring outside housings

3.2.10.2.1 Cable routing

Where cable is routed, it must be ensured that no moisture or damage to the lines may occur.

Multiple M screw fittings are not permitted; cable duct systems are allowed. Ready-made lines must be replaceable without disassembling the connector.

3.2.10.2.2 Ducts

Power lines are to be laid protected in metal ducts, and covers which are more than 100mm wide need to be designed with a hinge.

Accessible cable ducts shall be avoided as a rule and may only be used after consulting the Customer. If they are used, the cable ducts must be tread-proof.

Media-carrying lines may not be installed in the cable duct together with electrical lines.

The metal line ducts must be grounded.

3.2.10.2.3 Plug connections

Initiators and other peripheral devices shall be designed to be plug-in. The switch status must be displayed by LED. It must be easy to change the connected lines (e.g. in the cable trailing device).

Plug connections may not be routed in cable ducts. If plug connections are loaded with medium such as cooling lubricant, it has to be checked and guaranteed that the plug connections are resistant against the used medium.

The line length of sensors/actuators with fixed connection lines may only exceed a maximum cable length of 1.5m if they are easily accessible.

If connection cables come under heavy load, then "irradiated" cables with e.g. a high temperature range must be used.

If several plug connections are used next to one another, they must be kept in order to avoid confusion (e.g. by means of plug coding, specified line lengths, etc.).

Up to a rated power of 36A, all connection lines for system parts that must be disconnected for transport of the machine/machine system must have one-sided plug connections.

The structure of the sections for the cable drag chain is to be documented and the cable drag chain as an assembly must be replaceable through unplugging.

Plug connections for auxiliary equipment (e.g. pumps, filters, measurement control units, etc.) must be connected behind the main switch.

The line length of sensors/actuators with plug connectors may not exceed a max. length of 5m.

3.2.11 Electric motors and related equipment

3.2.11.1 Actual path measuring systems

Actual path measuring systems (e.g. glass scales) must be installed on the machine in such a way that they can be operated with minimal maintenance, i. e. are protected against dirt of any kind (e. g. using sealing air).

They must be mechanically fastened so that adjustments are not necessary when a component is replaced.

3.2.11.2 Drive elements and actuators

All drive and control elements (actuators) must be designed for continuous duty (100%).

3.2.11.3 Electric motor design

Electric motors are to be designed in the corresponding energy efficiency class IE according to the legal requirements. (see e.g. ZVEI: "Worldwide regulations for energy-saving motors").

3.2.11.4 Three-phase motors

Three-phase motors with a power of 7.5 kW must be designed with an electronic soft start function. Up to a performance of 4 kW, the connection must be enabled by means of a plug connection. For pumps and fans, frequency inverters have to be used.

The starting conditions are to be harmonized with the Customer's respective technical department.

3.2.12 Accessories and lighting

3.2.12.1 Electrical outlets

Within the switch cabinet, there must be a Schuko electrical outlet connected before the main switch.

All outlets < 20A inside and outside the switch cabinet must be additionally protected by means of RCD (current difference <30 mA) (see EN60204-1-2018).

Caution: When connecting "mobile machines", it must be considered that line-side RCD already exists.

3.2.12.2 Lighting

The switch cabinet lighting must be wired for each switch cabinet panel via its own door contact switch and be connected before the main switch.

An energy-saving LED machine illumination is to be installed which can be switched on/off.

3.2.12.3 Lighting and outlet circuit

Lighting and outlet circuits may not be connected on the secondary side of control transformers.

3.2.12.4 Workpiece and operating hour meter

The machine/machine system must include a workpiece meter which can be reset for the number of processed workpieces (total, OK/not OK parts).

A non-resetting operating hour meter (automatic mode) or a non-resetting system workpiece meter is required, preferably using software.

If cycle-dependent maintenance intervals are necessary, the machine/machine system must contain counting functions and a signaling system.

3.2.12.5 Measurement equipment

3.2.12.5.1 Key switch

It must be possible to deselect measuring devices via an authorization concept (EKS, key switch, password...) in automatic mode.

The design is to be coordinated with the Customer.

3.2.12.5.2 Measurement results

Measurement results must be displayed digitally and stored until the next workpiece is processed.

3.2.12.5.3 Measuring sensor

For every measuring sensor, the machine/machine system's technical documentation must contain the required test protocol (DIN EN ISO 9000) with an installation assignment (e.g. sensor number). If necessary, a calibrating instrument shall also be delivered in coordination with the Customer.

3.2.13 Warning signs and labeling of operating equipment

3.2.13.1 General requirements

Identification signs must always be

- engraved, etched or lasered in aluminum or two-layer plastic
- legible
- attached in a captive manner (permanently) at a clearly visible location
- attached next to the respective components, assemblies and devices
- attached next to the respective installation space, when the devices are concealed.
- The identification signs may not be located on replaceable components, assemblies and devices.
- Components with safety functions are to be marked as described in the "Work Safety, Risk Assessment" chapter.

3.2.13.2 Additional information

When marking components installed in the machine/machine system, the following information should be noted:

- The device names are also attached to all coverings.
- Arrows indicating the direction of rotation must be placed on all pumps and motors.

3.2.13.3 Inside the switch cabinet

The operating equipment within the switch cabinet must be permanently labeled on the assembly plate and component.

The designations and symbols shall comply with standards.

The designation between sensor/actuator level and PLC control must be intuitively consistent/uniform.

Safety-relevant components are to be marked with +SF in the BMK.

Component or location identification must be based on location or sheet.

3.2.13.4 Outside the switch cabinet

The operating equipment outside the switch cabinet must be completely, permanently and visibly labeled next to the component and on the cable using engraved/printed or etched signs. This also applies to any plugs, switch boxes, command boxes and operating elements.

All electrical installation space must be identified with a warning sign (lightning bolt).

3.2.13.5 Cable identification

All cables must be permanently labeled at both ends.

The target or source of the cable must be clear from the cable identification and the electrical diagram (e.g. terminal diagram).

3.2.13.6 Single conductor identification

Devices for which multiple wires must be disconnected when replacing the device must have permanent single conductor identification. Exceptions may be agreed with the Customer.

3.2.14 Technical documentation

(refer to section Documentation, page 34)

3.2.15 Checks and examinations (additional requirements for Europe)

The electrical test protocol must be created according to DIN EN 60204 (DGUV Regulation 3 [old: BGV A3]) and then included in the machine/machine system's technical documentation.

3.2.15.1 Checks and examinations (additional requirements for Germany)

A test protocol for the insulation resistance and the equipment grounding conductor's loop resistance must be included in the machine/machine system's technical documentation.

3.2.16 Startup, acceptance, training

For startup, acceptance and training see Document I General.

3.2.17 Other applicable documents

Number	Description
DIN EN ISO 9000 Quality Management Systems	Fundamentals and vocabulary (ISO 9000: 2005-12-01)

Table 7

3.2.17.1 Other applicable documents (additional for Europe)

Number	Description
DIN EN 60204-1	Electrical equipment of machines - see General requirements
DIN EN 61082-1	Preparation of documents used in electrotechnology
DIN EN 50178 (VDE 0160)	Electronic equipment for use in power installations
VDE0100-729	Requirements for special installations or locations - Operating or maintenance gangways

Table 8

3.2.17.2 Other applicable documents (additional for Germany)

Number	Description
VDA-LVE	Supply specifications for the electrical equipment of machines, machine systems and equipment.

Table 9

3.3 Mechanics

3.3.1 Scope of application

The technical instructions described here apply specifically to the design of the mechanics and the systems/technologies in the subchapters (hydraulics, pneumatics, lubricating technology, cooling lubricating technology...) for the machine/machine systems. They supplement the instructions listed in "General" document of the Technical Delivery Specifications of ZF Friedrichshafen AG and alongside these, are valid for all ZF plants.

3.3.2 Normative references

As a basic principle, the agreements listed in the document "I General Information" regarding normative references apply.

3.3.3 Definitions (additional requirements for Germany)

Definitions, included in the *General Part chapter* and in the VDA-LVE have to be adhered to.

3.3.4 General Requirements

3.3.4.1 Tool breakage control

3.3.4.2 Other instructions

No hoses may be installed around the chip area of the machine/machine system.

Industrial shock absorbers may not be used as a limit stop.

Alignment pins must be tempered and have internal threading if the alignment pin is not accessible from both sides.

If screws are used, only screwdriver systems with independent torque measurement lines may be used.

3.3.4.3 Test stations and measurement tools/gages requiring inspection

3.3.4.4 Measuring systems

All measurement equipment (mechanical, optical, electronic, hydraulic, pneumatic) within the machine/machine system must be adequately protected against all forms of damage as well as chip and cooling lubricant contamination.

Linear measurement systems (glass scales) must be equipped with sealing air and be easy to assemble, disassemble and adjust.

3.3.4.5 Drives

3.3.4.5.1 Ball screw drives

Ball screw drives must be protected against contamination and be durable. They must also feature lifetime lubrication or be lubricated with a centralized lubrication system.

It must be possible to remove the ball screw drives without disassembling the main assembly (e.g. carriage) in which they are integrated.

Ball screw drives must comply with the DIN 69051 and ISO 3408 series of standards.

3.3.4.5.2 Coupling systems

Coupling systems have to be aligned in such a way that it is possible to quickly adjust or replace the corresponding wear parts.

3.3.4.5.3 Chains and belts

Guide pulleys, turn wheels and chains must be lubricated via a centralized lubrication system.

3.3.4.5.4 Transmission

The transmission must have a power reserve of 10%.

Preferably, the transmission will feature life-time lubrication; otherwise, an oil level gage glass must be attached at an appropriate, visible spot to be able to check the oil level.

3.3.4.6 Workpiece and tool spindles

Workpiece and tool spindles that take longer than two seconds to slow down with a workpiece and/or operating equipment must have a brake (max. braking time $\leq 10\%$ of the normal slowing time without braking).

For each spindle, the machine/machine system's technical documentation must include a geometric measurement report (test run) and a frequency measurement report based on DIN/ISO specifications.

3.3.4.7 Warehouse

3.3.4.7.1 Rolling bearing units

Only rolling bearings with inner and outer ring based on DIN dimensions may be used; they must be sealed from foreign substances. It must be possible to pull off the rolling bearings for disassembly.

3.3.4.7.2 Plain bearing units

Hydrostatic bearings must come equipped with continuous pressure monitoring.

3.3.4.8 Guideways and linear systems

Guideways/Guideway elements must be tempered, replaceable and adjustable.

Standard linear systems shall be used. If necessary, spring-loaded limit stops shall be used.

3.3.4.9 Strippers and Covers

The strippers used in the machine/machine system must be permanently resistant to cooling lubricants, cooling lubricant vapor and chips as well as any mechanical and thermal loads.

Large covers on all sides must cover over the guide systems.

3.3.4.10 Sealing elements

All machine/machine system assemblies (e.g. spindle bearing arrangements, transmission cases and linear systems) must use suitable elements to seal out foreign particles (dirt, cooling lubricant, etc.) and seal in lubricants.

3.3.4.11 Closed cooling systems

Purity class ISO 4406	Pressure	Speed
17/15/12	> 40 bar	> 10 000 rpm
20/17/14	> 20 bar	< 10 000 rpm
21/19/17	< 20 bar	< 10 000 rpm

Table 10

The heat exchanger should be located outside of the reservoir.

3.3.4.11.1 Closed cooling systems (additional requirements for Germany)

Closed cooling systems must use oil that meets the following purity classes:

Purity class ISO 4406 (Hydraulic fluid power - Fluids - Method for coding the level of contamination by solid particles)

Compressor cooling units should always be designed with a 10-pin Harting plug (pin configuration see approved list for electrical engineering, motors and drives, plugs for motors), 2 stop cocks for the cooling unit lines, flow monitors, and when set up on level ground, with rollers. Pumps are to be used according to the approved list.

3.3.4.12 Chip conveyor

3.3.4.12.1 Switches

The chip conveyor must have a separate on/off switch and a directional reversing switch.

3.3.4.12.1.1 Switches (additional requirements for Germany)

The machine/machine system may not shut down when the on/off switch is used.

3.3.4.12.2 Eject height

The eject height for the chips must be at least 1,200 mm.

3.3.4.12.3 Accessibility for cleaning

The chip conveyor must be easily accessible for cleaning.

3.3.4.12.4 Other

All cavities in the chip conveyor must be protected from deposits of any kind.

3.3.4.13 Containers for liquids

For requirements, see "II Technical Equipment Instructions, TA04" Hydraulics.

3.3.4.14 Suction/Extraction devices

Risks caused by emissions must be assessed and, where required, dissipated and eliminated with suitable extraction and separation systems.

Explosion and fire protection is to be considered. If possible, separation systems must be suitable for recirculating air operation.

In the case of exhaust/outgoing air operations, it must be discussed with the Customer whether sufficient ambient air is available.

The supplier must provide a contactor relay with a potential-free changeover contact for the following functions:

- Extraction ON (potential-free contact closed)
- Extraction OFF (potential-free contact open)

3.3.4.14.1 Lines

Pipelines which are more than five meters long or have multiple bends must have revision openings.

All pipelines and hose assemblies must be designed with smooth inner walls. Spiral slip tubing is not permissible.

All hoses and pipelines must be easily accessible and easy to disassemble (quick-snap connections). As required, e. g. in the event of a risk of fire or explosion, they must conduct electricity and be fitted with equipotential bonding.

Pipelines for oil mist, emulsion vapor and dust suction/extraction devices must be sealed, i. e. completely drip-free and permanently durable. The materials they are made of must be resistant to oil mist, emulsion vapors and dust.

3.3.4.14.2 Filters

Instructions for extracting chips/dust with suction

- The filter elements must be cleaned according to differential pressure.
- Cleaning of the filters must be ensured in online as well as offline operating modes.

Instructions on extracting oil/cooling lubricant by suction/extraction devices

- Oil/Cooling suction/extraction devices must effectively collect and extract all vapors and aerosols produced during operation.

- Separation systems in recirculating air operation must feature a HEPA filter (High Efficiency Particulate Airfilter, filter class H13).

Instructions on suction/extraction devices for welding plants

Make sure that no sparks can get into the extraction system (meshed metal baffle / spark interceptor).

Instructions on suction/extraction devices for cleaning systems

Vapor and aerosol escaping is to be effectively prevented by taking suitable measures (vent condenser/ mist eliminator).

Instructions on suction/extraction devices for furnace systems

Make sure that exhaust gases (e.g. CO, CO₂) are effectively collected and disposed of (forced ventilation).

3.3.4.14.2.1 Filters (additional requirements for Germany)

Maintenance personnel must have easy access to the filter insert maintenance doors and be able to open them without any special tools.

It must be possible to reuse and clean prefilter cassette inserts.

The technical documentation of the machine/machine system must contain an IFA certificate for the filters.

3.3.4.14.3 Collecting elements (fume hoods)

Collecting elements are to be designed in such a way that they collect the hazardous substances as closely as possible to the source.

Make sure that the suction nozzle is fitted in the working space so that no fluids or chips can be flung into the nozzle. A height-adjustable baffle or deflection plate should always be fitted in front of the suction outlet. If necessary, attach an additional preseparator (possibly a chip pre-cyclone) after the suction outlet.

3.3.4.14.4 Outlet option

An outlet option must be provided for draining the collected medium. It must be attached freely accessible at a height of at least 400 mm (siphon, ball valve).

Dust discharge systems must be ergonomic. In the case of isolated quantities of dust particles exceeding 30 l per week, automatic discharge systems must be provided (e.g. double pendular flap, star feeder or worm conveyor).

3.3.4.14.5 Air volume

A three-phase AC motor must be used for the fan.

3.3.4.14.6 Contamination indicator

Filter systems must be equipped with visual displays to control contamination (differential pressure indicator).

A contamination indicator must be visible from the outside.

3.3.4.14.7 On/Off switch

The suction/extraction unit must have a separate on/off switch that can be locked and reached from the ground.

3.3.4.14.7.1 On/Off switch (additional requirements for Germany)

The machine/machine system may not shut down when the on/off switch is used (e.g. to replace the filter).

3.3.4.15 Welding technology

Rectifiers and wire feed units must be designed to be easily accessible, and so that they can be unplugged and changed quickly.

Long supply pipes shall be avoided.

Dual drives must be coordinated with the Customer.

3.3.4.16 Safety guards

See also Safety of machinery, environmental and fire protection in Chapter I "General Part"

3.3.4.16.1 Changing frame

The safety guards must be located on the outside of the machine/machine system by means of a changing frame. It must be possible for one person to easily replace the safety guards from the outside.

3.3.4.16.2 Fastening

The safety guards must be sufficiently secured in the machine paneling against any load or stress that might occur while the machine/machine system is operating.

3.3.4.17 Marking

3.3.4.17.1 General requirements

All devices within a system including the hose assemblies must be distinctively and permanently marked.

Identification signs must always be

- engraved, etched or lasered in aluminum or two-layer plastic
- legible
- attached permanently (indelibly) at a clearly visible location
- attached next to the respective components, assemblies and devices
- attached next to the respective installation space, when the devices are concealed.
- Identification signs may not be located on replaceable components, assemblies and devices.
- Marking of components with safety functions (*refer to section Work safety, page 16*).

3.3.4.17.2 Additional information

The following information is important for marking the mechanical components installed in the machine/machine system:

- The device names are also attached to all coverings.
- All workpiece-dependent operating equipment and replacement parts are to be identified with the respective ZF operating materials number (tools, clamping device and fixtures, etc.).
- Arrows indicating the direction of rotation must be placed on all pumps and motors.

3.3.4.18 Maintenance doors (additional requirements for Germany)

Maintenance doors must not be fitted with dual-bit locks; these may only be fitted on electrical housings. Preferably, square socket locks (8mm) should be used.

3.3.4.19 Annex: Other Applicable Documents

3.3.4.19.1 Global requirements

ISO 4406 Hydraulic fluid power – Fluids – Method for coding the level of contamination by solid particles

3.3.4.19.2 European requirements

Re. 16 Suction/Extraction Devices

Directive 2006/42/EC of the European Community on machines (Machinery Directive)

3.3.4.19.3 German requirements

Re. Rolling bearing units

Inner and outer ring based on DIN dimensions

Re. Filters

Filter materials must be certified by the BGIA (dust/filter class). The BGIA inspection certificate must be supplied.

3.4 Hydraulics

3.4.1 Accessibility

All components and assemblies must be easily accessible for maintenance and repair work and may not be concealed by pipelines or hose assemblies or any other components/assemblies.

No screw connections are permitted in hard-to-reach areas of the hydraulic pipework.

3.4.2 Collecting trays

(refer to section Environmental protection, page 19)

3.4.3 Design

The hydraulic system must be designed to ensure that there is adequate reserve pressure and volume within a working cycle.

3.4.4 Accessibility

Protective measures must take into account the local conditions at the installation site that affect the machine/machine system.

3.4.5 Adjustment devices

Adjustment devices on components (e.g. pumps, flow regulators, pressure valves, etc.) must be secured against accidental adjustments.

3.4.6 Normative references

3.4.6.1 General Requirements

These Technical Equipment Instructions for the machine/machine system's hydraulic system are based on DIN EN ISO 4413 which must be complied with, including any recommendations and additional requirements.

3.4.7 Liquid reservoirs

3.4.7.1 Intake lines

Intake lines must end at least 50mm above the reservoir floor and be mechanically decoupled.

3.4.7.2 Design

Liquid reservoirs must be sealed from contaminants getting in.

The liquid reservoir's size must be designed to be at least three to five times the pump capacity.

Two easily accessible (reserve) bores in accordance with the respective size of the suction tube / standard thread (closed with plug) must be planned for the container so that e.g. oil filtering is enabled during bypass operation.

3.4.7.2.1 Design (additional requirements for Germany)

Fluid containers must comply with DIN 24339 (container model AN, cover model C).

Only high-endurance pressure accumulators with a load cycle > 2,000,000 may be used.

3.4.7.3 Fluid-level indicator

An accessible and replaceable sight glass shall be used to indicate the pressure fluid level. It must be externally visible when it is being filled, during operation and when the machine/machine system is down. Dip sticks are not permitted.

The markings for the maximum level when the machine/machine system is down and for the maximum and minimum levels when the machine/machine system is running must be permanently marked on the level indicator and well visible from the outside.

3.4.7.4 Level control

There must be a level control unit in the fluid container with two shift points for the minimum level:

- 1. Switch point > oil level min > advance warning (refill oil)

- 2. Switch point -> oil level < min -> shut-down (after cycle end)

3.4.7.5 Operating temperature

When the ambient temperature is at its maximum at the machine/machine system's location, the maximum pump input temperature prescribed by the pump manufacturer for the hydraulic system may not be exceeded.

3.4.7.6 Temperature monitoring

Proof shall be provided that the temperature in the liquid reservoir cannot exceed 65°C.

Temperature monitoring must be secured with a switch point:

- Switch point -> oil too hot -> shut-down (after the cycle end).

3.4.7.7 Ventilation filter

The liquid reservoirs must have a ventilation filter. The ventilation filter's filter element must be replaceable; it must be finer than the smallest filter in the system.

Under very dirty or dusty conditions, the ventilation filter must have a visual contaminant indicator.

3.4.7.8 Filling

The fluid container must be filled via a filter (e.g. spouts with integrated filler inlet filter).

3.4.7.9 Drain

A drain with blind plug must be installed at the lowest point of the liquid reservoir.

3.4.8 Pumps

The pump performance reserve of all pumps used in the machine/machine system must be at least 20%. These pumps are preferably volume or pressure-controlled.

The pumps must be mounted outside the reservoir/tank.

3.4.9 Cylinder

3.4.9.1 Running surfaces

The piston rod running surfaces must be tempered, micro-machined and corrosion-proof.

3.4.9.2 Damping

Precise cylinder motions shall be dampened in end position (possibly with dashpots).

3.4.10 Valves

3.4.10.1 General Requirements

The valves used in the machine/machine system's hydraulic system must comply with DIN 24340-2 and DIN ISO 7368.

3.4.10.2 Modular design

Linked valves (linking systems) must feature modular design.

The linking and control plates must be mounted on the assemblies rigidly, securely, and strain-free.

3.4.10.3 Electric actuation (additional requirements for Europe)

For valves with electrical connection – not for proportional valves – device plug connections (line outlets) must be supplied with LED, protective diode, connection diagram in accordance with DIN EN 175301-803, 24 V DC voltage and a protective circuit.

3.4.10.3.1 Electric actuation (additional requirements for Germany)

Proportional valves must have a device plug connection (line outlet).

3.4.10.4 Manual operation

It must be possible to manually operate electrically operated directional valves, except for proportional and proportional servo valves (manual auxiliary operation in case of emergency); however, operating the valve by accident must be prevented.

3.4.10.5 Safety valves

The safety valve must accommodate the allowable pressure of the pressure accumulator with the ability to backwash the entire pump capacity. Any resulting increase in pressure may not exceed 10%.

3.4.10.5.1 Safety valves (additional requirements for Europe)

All safety valves must have a CE mark and the relevant EU declaration of conformity must be included in the machine/machine system's technical documentation.

3.4.10.6 Shut-off valve and non-return valve

A shut-off valve (stop cock) must be installed in the supply line and a non-return valve in the tank line, respectively, for linkage and control plates.

3.4.11 Pressure accumulator

3.4.11.1 General Requirements

Safety shut-off blocks must be used for all pressure accumulators.

Movement caused by a shut-down (also "EMERGENCY STOP") or a power outage may not endanger operators or the machine/machine system.

Only fixed pipelines leading to the pressure accumulators are permitted.

3.4.11.1.1 General requirements (additional requirements for Europe)

The pressure devices must comply with the directive on pressure devices (DGRL 97/23/EC) and the directive for simple pressure vessels (2009/105/EC) and the AD 2000 Z1 standards.

The following documentation must be supplied for the hydraulic accumulator:

- Drawings of the reservoir with material-related information
- EU declaration of conformity for the reservoir and the safety valves
- Maximum permissible endurance for the reservoir
- Risk assessment
- Operating Instructions

3.4.11.2 Filling gas

Nitrogen must be used as filling gas for the pressure accumulator.

Bladder accumulators are to be installed upright.

Inflation pressures above 180 bar should be avoided if possible.

The inflation pressure indicator must be permanently applied next to the pressure accumulator (see marking of components).

3.4.12 Pipework

3.4.12.1 Pipelines

Seamlessly drawn stainless steel pipes in compliance with DIN EN ISO 1127 must be used in areas of the machine/machine system at risk of corrosion (chemicals, water spray, condensation, etc.).

3.4.12.1.1 Pipelines (additional requirements for Germany)

For pipelines, seamlessly drawn precision steel tubes must be used which meet the requirements of DIN EN 10220.

3.4.12.2 Hose assemblies

Hose assemblies must comply with DIN 20066 and may only be used:

- for moving units
- when units/assemblies are changed due to production requirements
- to dampen mechanical and hydraulic vibrations and/or noises
- for measurement lines.

The failure of a hydraulic hose assembly (leakage of pressure medium / banging of the hose) must not become a threat for employees. This hazard may also be prevented by ensuring that the hose assemblies used within the work station's range or at transport routes are equipped with protective covers and safety chains / wire ropes or screens.

3.4.12.2.1 Hose assemblies (additional requirements for Germany)

Hose assemblies which are more than 2 years old must not be installed.

3.4.12.3 Line connections

3.4.12.3.1 Number

The number of connections in the pipework must be kept to a minimum (e.g. using bending pipes instead of elbow joints, distribution blocks instead of T connections, etc.).

3.4.12.3.2 Flange connections

Beyond a nominal size of DN 40, flange connections must have O-ring seals.

3.4.12.4 Pressure measurement points

3.4.12.4.1 Position

The machine/machine system must have a pressure measurement point on each pressure switch and for each pressure overflow and safety valve.

In addition to that, to perform pressure tests, accessible pressure measurement points must be provided with M 16x2 screw connections (Minimess connection) on all cylinder control lines near the cylinder connections both before and after each pressure line filter.

3.4.12.4.2 Manometer selector valve

All pressure measurement points are to lead to one manometer selector valve where the selected operating pressure is displayed.

3.4.13 Filters

3.4.13.1 General Requirements

The pressure liquid filters installed in the machine/machine system must ensure that the pressure liquid is constantly kept clean.

The machine tool filters must last for at least six months under the machine's operating conditions. At the same time, the pressure fluid must be kept clean according to specification.

3.4.13.1.1 General requirements (additional requirements for Germany)

Only pressure liquid filters complying with DIN 24550 are permitted.

3.4.13.2 Purity

The selection of the purity class is always determined by the most sensitive component:

- General hydraulics: Classification based on ISO 4406, minimum purity class 19/16/13.
- Proportional valves: Classification based on ISO 4406, minimum purity class 17/15/12.
- Servo valves: Classification based on ISO 4406, minimum purity class 15/13/10.

3.4.13.3 Accessibility

Filters must be accessible and the filter inserts replaceable without disassembling other components/assemblies.

3.4.13.4 Monitoring filter soiling

The filters must have an electronic soiling indicator with a readout/message on the control panel. If the maximum permissible level of soiling for the filter is exceeded, the machine/machine system must shut down in accordance with the agreed criteria.

The filter soiling level must be monitored at two switch points:

- 1. Switch point -> filter soiling 75% -> advance warning: "Change filter!"
- 2. Switch point -> filter soiling 100% -> shut-down (after the cycle end).

3.4.13.5 Other instructions

Using bypass filters is preferable.

Return flow filters with bypass valve are permitted only in connection with pressure filters.

Pressure filters may only be used with a bypass valve. Pressure filter as protective filter only without bypass valve and only with high-pressure filter elements.

Filters with screw cartridges and intake filters are not permitted.

Filters behind safety valves are not permitted.

3.4.14 Heat exchangers

Only safety heat exchangers are permitted in conjunction with drinking water/river water.

Immersion heaters (surface power density may not exceed $0.7\text{W}/\text{cm}^2$) and oil preheaters must be secured with a safety thermostat or dry protection.

3.4.15 Pressure fluid

3.4.15.1 Use

The pressure fluid used in the hydraulic system may not be used as lubrication.

3.4.15.1.1 Use (additional requirements for Germany)

Only hydraulic fluids based on DIN 51524-2 may be used that do not corrode lead or lead-containing storage materials.

3.4.15.2 Fire hazard

If there is a fire hazard at the machine/machine system, the pressure liquid must be flame resistant (e.g. hardening furnaces).

3.4.16 Additional information

The following information is important for marking the hydraulic system installed in the machine/machine system:

- For valves, the controlled function (e.g. "release clamping device") must be included in addition to the identification (e.g. item no.) according to the circuit diagram.
- For pumps, the type of use (e.g. main pump, feed pump, control pressure pump, etc.) must be indicated

- For pressure accumulators, the gas preset pressure must be indicated
- Electrical designations must be indicated according to the circuit diagram
- For oil reservoirs, the type and quantity of the hydraulic fluid must be indicated
- For device plug connections (line outlets), the detachable parts must also be marked with signs
- For cylinders, the set pressure and the cylinder designation must be indicated
- The pressure measurement points must be clearly identified (e.g. MM1, MM2, etc.) on the machine/ machine system in compliance with the circuit diagram and with the target pressure value indicated (in bar).

3.4.17 Annex: Other Applicable Documents

3.4.17.1 Annex: Other Applicable Documents

ISO 4406: Hydraulic fluid power – Fluids – Method for coding the level of contamination by solid particles

DIN EN ISO 4413: Hydraulic fluid power - General rules and safety requirements for systems and their components

3.4.17.2 European requirements

Re. General requirements for pressure vessels, pipelines, equipment accessories and hydraulic accumulators

Directive 97/23/EC of the European Community on pressure equipment

Directive 2009/105/EC on simple pressure vessels

new directive, valid from 2016-04-20: 2014/29/EU 6.17.2 AD 2000 Z1 regulations (AD: Working group on pressure vessels).

Re. Electric requirements (valves) 6.17.2 "DIN EN 175301-803 Detail Specification: Rectangular connectors - Flat contacts, 0.8 mm thickness, locking screw not detachable

Re. Pipelines

DIN EN 10220 Seamless and welded steel tubes - Dimensions and masses per unit length
DIN EN ISO 1127 Stainless steel tubes - Dimensions, tolerances and conventional masses per unit length

3.4.17.3 Legal requirements (additional requirements for Germany)

Re. General requirements (Normative references)

Re. General requirements for pressure vessels, pipelines, equipment accessories and hydraulic accumulators

Technical Equipment Instructions

All hydraulic accumulators are subject to the operational safety requirements §15 as well as the corresponding technical rules for pressure vessels (TRBS).

Re. Design (Liquid reservoirs)

DIN 24339 Fluid power; hydraulic reservoirs made of steel; dimensions, requirements, test methods; nominal capacity 63 to 1250 (reservoir form AN, cover form C).

Re. General requirements (Valves)

DIN 24340-2 Hydraulic valves; mounting surfaces and connecting plates for directional control valves DIN ISO 7368 Hydraulic fluid power - Two-port slip-in cartridge valves - Cavities

Re. Hose assemblies

DIN 20066 Hydraulic fluid power - Hose assemblies - Dimensions, requirements

Hose assemblies must be inspected regularly, in accordance with the respective DIN standard

Re. General requirements (Filters) 6.17.3 DIN 24550 Fluid power - Hydraulic filters

Re. Use (Hydraulic fluid)

DIN 51524-2 Pressure fluids - Hydraulic oils - Part 2: HLP hydraulic oils; Minimum requirements

3.5 General pneumatics requirements

3.5.1 Design

The pneumatic system must be monitored during operation. Its design must ensure that it will perform without defects at 90% network supply line pressure at the machine/machine system location.

3.5.2 Exhaust air

Oil mist residues are not permitted in the exhaust air.

Cooling lubricants and chips may not be taken up by the exhaust air.

3.5.3 Normative references

3.5.3.1 General Requirements

ISO 4414 will serve as the basis for these Technical Equipment Instructions for the machine/machine system's pneumatic system. It is binding along with any recommendations and additional requirements it includes.

3.5.3.2 Requirements for pressure vessels, pipelines and equipment accessories

For requirements, see Technical Equipment Instructions, TA03 Hydraulics.

Casing with press fittings is not allowed!

3.5.4 Cylinder

The counterforce in every cylinder must be a max. 70% of the effective cylinder-piston force.

The number of variants (model variety) of the cylinders used in the machine/machine system must be as low as possible.

3.5.4.1 Cylinders (additional requirements for Europe)

In accordance with DIN ISO 6432/DIN ISO 15552, cylinders with standard strokes must be used for the pneumatic system in the machine/machine system.

3.5.5 Valves

3.5.5.1 General Requirements

Valves must be concentrated on connection plates whenever possible. The bus system must be determined with the Customer.

When the main switch is turned off, the pneumatic supply line must be interrupted by an automatically closing valve. Pressure-accumulating components must be force-ventilated.

3.5.5.2 Electromagnetic valves (additional requirements for Europe)

Use of electrical line outlets in accordance with DIN EN 175301-803, magnet voltage 24 V DC with LED display and protective circuits.

3.5.5.2.1 Electromagnetic valves (additional requirements for Germany)

It must be possible to manually operate an electromagnetic valve (manual auxiliary operation in case of emergency); however, it must not be possible to operate the valve by accident.

3.5.5.3 Pressure control valves

The pressure control valves must have secondary ventilation and a pressure gage to display secondary pressure.

3.5.5.4 Flow control and check valves

Flow control and check valves must be used whenever a defined speed set by pneumatic drives is desired.

3.5.6 Pipework

3.5.6.1 Maintenance unit

The pneumatic system must have a maintenance unit that is installed at an accessible place on the machine/machine system.

The maintenance unit must have the following components/assemblies:

- Shut-off valve (i.e. called cut-off cock or stopcock) with ventilation,
- Filter,
- Pressure regulator with pressure gage,
- Pressure build-up valve to prevent uncontrolled movements (to protect people and the machine/machine system),
- Lubricator (as needed),
- Water separator (as needed).

3.5.6.2 Line connections

No line connections are permitted in hard-to-access areas of the pneumatic pipework.

3.5.6.3 Mufflers

All exhaust air outlets in the pneumatic system must have mufflers. Only low-noise nozzles and covers may be used. They must not be mounted at head level.

3.5.6.4 Pressure gage

Every adjustable pressure must be easy to read from a pressure gage or a Minimes measuring point.

The pressure gage must display the minimum pressures in green markings and the maximum ones in red.

3.5.7 Marking

3.5.7.1 Additional information

For the identification of the pneumatics installed in the machine/machine system, the following information is important:

- In compliance with the wiring diagram, the function identification must be affixed directly to the component or assembly in the form of component identification in plain text.

- The pressure measurement points must be clearly identified (e.g. MM1, MM2, etc.) on the machine/ machine system in compliance with the circuit diagram and with the target pressure value indicated (in bar).

3.5.8 Annex: Other Applicable Documents

3.5.8.1 Annex: Other Applicable Documents

Re. Normative references, General requirements

ISO 4414 Pneumatic fluid power - General rules and safety requirements for systems and their components

Re. Cylinders

DIN ISO 6432 Pneumatic fluid power; single rod cylinders; 10 bar (1000 kPa) series; bores from 8 to 25 mm; mounting dimensions

DIN ISO 15552 Pneumatic fluid power - Cylinders with detachable fasteners, 1 000 kPa (10 bar) series, bores from 32 mm to 320 mm - Basic, mounting and accessories dimensions

3.5.8.2 European requirements

Checked safety valves with CE marking - issued by a correspondingly authorized body - are to be used.

Re. Electromagnetic valves

DIN EN 175301-803 Detail Specification: Rectangular connectors - Flat contacts, 0.8 mm thickness, locking screw not detachable

3.6 Lubricating technology

3.6.1 General Requirements

3.6.1.1 Accessibility

No screw connections are permitted in hard-to-reach areas of the pipework.

3.6.1.2 Collecting trays

See Safety of machinery, environmental and fire protection

3.6.1.3 Central lubrication

The central lubrication used must be self-ventilating and automatic with an integrated reservoir level monitor.

The design of the central lubrication must ensure that there is adequate reserve pressure and volume within a work cycle.

3.6.1.4 Oil mist lubrication system

If an oil mist lubrication system is used in the machine/machine system, the oil mist lubrication system must ensure that the oil mist is collected in an enclosed area.

3.6.1.5 Lubricant guidelines

The number of lubricants used in the machine/machine system must be as low as possible.

The use of lubricants must be economical and comply with applicable environmental requirements, guidelines, laws, etc.

The machine/machine system's technical documentation must state the lubricant consumption for eight hours under normal operating conditions.

The lubricant reserve quantity must be sufficient to cover at least 100 operating hours before the next filling.

3.6.1.6 Lubricating nipples

If lubricating nipples must be used, this shall be coordinated with the Customer.

Lubricating nipples must be freely accessible, e.g. without having to remove covers. If pipelines are used, they must be able to withstand the applied pressure (hand-lever press min. 500 bar).

All lubricating nipples which are only required for initial lubrication need to be disassembled.

3.6.1.6.1 Lubricating nipples (additional requirements for Germany)

Button head lubricating nipples as defined in DIN 3404 are not permitted.

3.6.1.7 Other instructions

All components and assemblies of the machine/machine system which are subject to mechanical wear must be designed with lifetime lubrication.

If recirculating lubrication is used, the lubricant involved must be separated from the other coolants and lubricants used in the machine/machine system.

3.6.2 Normative references (additional requirements for Germany)

DIN/ISO 5170 in conjunction with DIN 8659 (Parts 1 and 2) and DIN 51502 will serve as the basis for these Technical Equipment Instructions for the machine/machine system's lubricating technology.

3.6.3 Lubricant containers

3.6.3.1 Design

Lubricant containers must be sealed from contaminants.

3.6.3.1.1 Design (additional requirements for Germany)

Free-standing lubricant reservoirs with a volume over 60 l must comply with DIN 24339 (container model AN, cover model C).

3.6.3.2 Fluid-level indicator

An accessible and replaceable sight glass is to be used to indicate the lubricant level. It must be externally visible when it is being filled, during operation and when the machine/machine system is down. Dip sticks are not permitted.

3.6.3.3 Level control

There must be a level control unit in the lubricant container with two switch points for the minimum fluid level:

- 1. Switch point oil level min, advance warning (refill with oil)
- Switch point oil level < min shut-down (after cycle end).

3.6.3.4 Temperature monitoring

If the lubricant temperature has a significant impact on the function of the machine/machine system's lubricated components and assemblies, the lubricant temperature must be monitored and displayed. The minimum/maximum temperature limits must also be indicated.

- Temperature monitoring must be designed with a switch point:
- Switch point oil too hot shut-down (after the cycle end).

3.6.3.5 Ventilation filter

The lubricant containers must have a ventilation filter for venting. The ventilation filter's filter element must be replaceable; it must be finer than the smallest filter in the system.

Under very dirty or dusty conditions, the ventilation filter must have a visual contaminant indicator.

3.6.3.6 Filler necks

The filler necks must have a nominal diameter of at least 40 mm.

When lubricating oil is used, the filler neck must have a filler inlet filter with a mesh size of 0.8 mm.

3.6.4 Pipelines and hose assemblies

3.6.4.1 Design

Pipelines and hose assemblies must be protected. They must be installed in such a way that they do not impede or disrupt the function of moving components and assemblies.

Minimum dimensions for the inside diameter of pipelines and hose assemblies:

- Main lines: 6 mm
- Lubricating point lines: 4 mm.

Pipes made of stainless steel in compliance with DIN ISO 1127, material number 1.4571 n1, must be used in areas of the machine/machine system at risk of corrosion (chemicals, water spray, condensation, etc.).

3.6.4.1.1 Design (additional requirements for Germany)

Compression couplings as defined in DIN 2353 must be used.

3.6.4.2 Fastening (additional requirements for Germany)

Pipelines and hose assemblies must be fastened to the machine/machine system with pipe clamps in accordance with DIN 72571 and DIN 72573.

3.6.5 Distribution

3.6.5.1 General Requirements

The distributor must be located as close as possible to the lubricating point.

The distributor outlets may only be provided in each case for the lubricant supply of one lubricating point.

The distributor outlets must have a recognizable numbering system. The numbers (incl. identification of the lubricating point) must appear in a distributor diagram attached to machine/machine system.

3.6.5.2 Progressive distributors

Lubricant must be fed in with compulsory dosed lubricant quantities by means of a progressive distributor or an individual doser with monitoring after the last lubrication point.

Large presses must come equipped with a progressive distributor, an upstream quantity regulator and a mesh screen.

3.6.5.3 Metering/Dosing units

Lubricant systems with dosing units must be self-ventilated.

3.6.5.4 Dual-line distributors

Dual-line distribution systems may only be used after prior approval from the Customer.

3.6.6 Filters

3.6.6.1 General Requirements

The machine tool filtering must be designed so that the filter elements last at least six months under the machine's operating conditions while at the same time warranting that the required purity of the medium is maintained.

The filter manufacturer and/or subcontractor must always be included in the design of the filters. This service is currently offered free of charge by the companies "Pall" and "Hydac", for example.

Intake filters are not permitted.

A pressure filter with electrical and visual contamination indicator must be used if band filter and hydrostatic filter systems are used.

3.6.6.2 Purity

The lubricant must be kept pure at least in accordance with the required purity grade 19/17/14 (classification acc. to ISO 4406) over the entire lifetime of the machine/machine system.

3.6.6.3 Accessibility

Filters must be accessible and the filter inserts replaceable without disassembling other components/assemblies.

3.6.6.4 Monitoring filter soiling

The filters must have an electronic soiling indicator with a readout/message on the control panel. If the maximum permissible level of soiling for the filter is exceeded, the machine/machine system must shut down in accordance with the agreed criteria.

The filter soiling level must be monitored at two switch points:

- 1. Switch point filter soiling 75%, advance warning: "Change filter!"
- Switch point filter soiling 100% shut-down (after the cycle end).

3.6.6.5 Shut-off valve

A shut-off valve (i. e. stop cock) must be installed for band filter systems with an oil return quantity ≥ 60 l so that the oil may remain in the lubrication system lines during maintenance and repair work.

3.6.7 Control of lubricant supply

All friction points in the machine/machine system must be lubricated before the machine/machine system starts up.

For periodical lubrication, the first lubrication cycle is to take place at the same time as the machine/machine system is switched on.

The lubricant supply control must work either as a function of travel or time.

If the machine/machine system is repeatedly switched on and off, measures must be taken to ensure that it is not overlubricated by periodic lubrication systems.

When the work cycle stops, so must the lubrication cycle.

3.6.8 Monitoring the lubricant system

3.6.8.1 General Requirements

All messages from the monitoring devices must be displayed in a central location on the operator panel.

The criteria for shutting down the machine/machine system must be determined for each particular case.

3.6.8.2 Pressure-dependent monitoring

A pressure switch must be integrated at the end of the main line for lubrication systems with dosing units.

A pressure switch with the switch points "minimum pressure" and "maximum pressure" must be used between the pump and the first distributor for lubrication systems with progressive distributors.

3.6.8.3 Monitoring the lubricant flow rate

The lubricant flow rate must be monitored for especially vulnerable friction points in the machine/machine system.

The Contractor must automatically inform the Customer's maintenance departments about especially vulnerable friction points in the machine/machine system. This information shall be included in a separate section of the machine/machine system's technical documentation.

3.6.8.4 Monitoring system soiling

For lubrication systems with reservoirs that hold over 50 l, a Minimes measuring connection as defined by DIN must be attached to an optimal flow location in the pressure line so that a lubricant sample may be taken.

For lubrication systems with reservoirs that hold over 50 l, a Minimes measuring connection M16x2 as defined by DIN must be attached to an optimal flow location in the pressure line so that a lubricant sample may be taken.

3.6.9 Marking

3.6.9.1 General Requirements

3.6.9.2 Additional information

The following information is important for marking the lubricating technology installed in the machine/machine system:

- All devices must be identified according to the lubrication circuit diagram with identification plates.
- The lubrication instructions must be engraved or etched using a diagram made of aluminum and permanently attached in a clearly visible location (e.g. next to the control panel or the switch cabinet) on the machine/machine system.

3.6.10 Annex: Other Applicable Documents

3.6.10.1 International requirements

Re. Normative references

DIN ISO 5170 Machine tools; lubrication systems

Re. Purity

ISO 4406 Hydraulic fluid power - Fluids - Method for coding the level of contamination by solid particles

3.6.10.2 Requirements (additional requirements for Germany)

Re. Other instructions

Button head lubricating nipples as defined in DIN 3404

Re. Normative references

DIN 51502 Designation of lubricants and marking of lubricant containers, equipment and lubricating points

Re. Lubricant containers, design

DIN 24339 Fluid power; hydraulic reservoirs made of steel; dimensions, requirements, test methods; nominal capacity 63 to 1250

Re. Pipelines and hose assemblies, design

DIN EN ISO 1127 Stainless steel tubes - Dimensions, tolerances and conventional masses per unit length
DIN 2353 Non-soldering compression fittings with cutting ring - Complete fittings and survey

Re. Fastening

DIN 72571 Pipe clamps - One-sided fastening DIN 72573 Pipe clamps - Two-sided fastening

3.7 Cooling lubricating technology

3.7.1 Leak tightness

The machine/machine system must not leak any and be resistant to cooling lubricant.

3.7.2 Other requirements

Separate pumps are to be used for coolant, high pressure and flushing.

The machine/machine system's interior and exterior must be flushed so that no machining residues are left in the cooling lubricant system. The cooling lubricant must completely drain from the machine/machine system's interior.

When the cooling lubricant drains, there must be no backup of the medium or creation of foam.

3.7.3 Cooling lubricant systems

3.7.3.1 Individual systems

3.7.3.1.1 General Requirements

Band filter systems or backflushing filters must be used.

For water-based cooling lubricants, a settling zone with extraction system shall be provided for flooding leak oil.

3.7.3.1.2 Cooling lubricant reservoirs

Cooling lubricant reservoirs must be sealed from contaminants. A medium return from the feed and drain units into the cooling lubricant reservoir is not permitted.

The cooling lubricant reservoir's size must be at least three to five times the pump capacity.

3.7.3.1.2.1 Cooling lubricant reservoirs (additional requirements for Germany)

Cooling lubricant reservoirs must comply with VDI 3035.

3.7.3.1.3 Filling

It must be possible to fill the cooling lubricant system with cooling lubricant while the machine/machine system is being operated.

3.7.3.2 Central systems

If a central cooling lubricant system or a central cooling lubricant supply should be provided, the details must be discussed with the Customer.

3.7.3.3 Cooling systems

In accordance with the agreements reached with the Customer.

3.7.4 Filters

The cooling lubricant system filters must last for at least three months under the machine's operating conditions. At the same time, the cooling lubricant must be kept clean according to the specifications/operating conditions.

Filters must be accessible and the filter inserts replaceable without disassembling other components/assemblies.

It must be possible to clean the filters quickly. Automatic cleaning systems may also be used.

A filter must be placed in supply lines upstream of coolers and heat exchangers.

3.7.5 Valves

When the main switch is turned off, the media supply and removal line must be interrupted, e.g. by automatically closing valves.

When the workpiece is changed manually, a solenoid valve must automatically interrupt the cooling lubricant feed.

The solenoid valve design and its activation must comply with the Federal Water Act (WHG). Pressure blows in the pipework are not permitted.

3.7.6 Other assemblies

The interior of the dividers, turrets, headstocks, measuring systems or other assemblies that are integrated in the cooling lubricant system or in other surrounding media systems must be charged with positive pressure (sealing air).

3.7.7 Pipes and hose assemblies (additional requirements for Germany)

Cooling lubricant transport lines must be black pipe or made of S235JR (St 37). The pipeline must be labeled according to DIN 2403/2404 (type of medium, direction of flow).

3.7.8 Flush line

A rinsing hose R ½" with rinsing gun must be provided to clean the surface of components and assemblies in the machine/machine system's interior with cooling lubricant instead of compressed air.

3.7.9 Annex: Other Applicable Documents (additional for Germany)

3.7.9.1 Requirements (additional requirements for Germany)

Re. Cooling lubricant reservoirs

VDI 3035 Requirements for machine tools, manufacturing facilities and peripheral equipment when working with cooling lubricants

DIN 2403 Identification of pipelines according to the fluid conveyed

DIN 2404 Identification Colour Code for Heating System Pipelines

4 Technology-specific requirements

4.1 Requirements for pipelines for induction hardening installations

The pipelines for the cooling medium must be designed in stainless steel.

4.2 GDE interface according to VDI 2610

The gear cutting machine (processing and measuring machine) must be designed according to the GDE interface (VDI 2610). The GDE interface must ensure automatic importing and exporting of GDE data. GDE data include, e.g. gearing master data, modifications, tolerances, process, tool, and measurement data for CNC program creation and/or CNC program modification.

The GDE data are provided to the machine via the production network. In the event of a network failure, the data must be entered manually via the machine control unit.

Detailed coordination must take place between the Contractor and GDE contact person at ZF before placing the order.

ZF Friedrichshafen AG
Fabrikdatenorganisation/Factory Data Organization
FDO Support ZF Group
fdo@zf.com
www.zf.com

[staticImage with key "ZF" in group Logos_Images not found]