



<h1 style="margin: 0;">AEROSPACE RECOMMENDED PRACTICE</h1>	ARP5526™	REV. F
	Issued	2003-01
	Revised	2022-05
Superseding ARP5526E		
Aircraft Seat Design Guidance and Clarifications		

RATIONALE

The change in this revision represents the latest agreement obtained by the SAE SEAT Committee to include the latest industry needs (limitation to one standard literature pocket, adding object entrapment, under seat baggage definition, adding details for tamper-evident device, e.g., Lifestage storage location) including consideration of current regulatory standards and guidance. It includes a harmonization with AS8049 and ARP6909 as well as some improvements for the wording and conversion errors.

TABLE OF CONTENTS

1.	SCOPE.....	5
2.	APPLICABLE DOCUMENTS.....	5
2.1	SAE Publications.....	5
2.2	NAS Publications.....	5
2.3	CFR Publications.....	5
2.4	FAA Publications.....	5
2.5	Civil Aerospace Medical Institute.....	6
2.6	NASA Publications.....	6
2.7	UL Publications.....	6
2.8	RTCA Publications.....	6
3.	RECOMMENDED PRACTICES.....	6
3.1	Seat Back Handhold in Turbulence.....	6
3.1.1	Applicable Policy and Regulations.....	6
3.1.2	Recommended Practice.....	7
3.2	Seat Belt Misalignment/Disengagement.....	7
3.2.1	Applicable Policy and Regulations.....	7
3.2.2	Recommended Practice.....	7
3.2.3	Examples.....	8
3.2.4	Y-Belts.....	11
3.3	Life Vest/Life Jacket Retrieval.....	12
3.3.1	Applicable Policy and Regulations.....	12
3.3.2	Recommended Practice.....	13
3.3.3	Life Vests in Legrests Considerations.....	13
3.4	Friction Fit Components.....	14
3.4.1	Applicable Policy and Regulations.....	14
3.4.2	Recommended Practice.....	14
3.5	Fire Containment - Cavity Fully Enclosed/Open.....	14
3.5.1	Applicable Policy and Regulations.....	14
3.5.2	Recommended Practice.....	14

SAE Executive Standards Committee Rules provide that: "This report is published by SAE to advance the state of technical and engineering sciences. The use of this report is entirely voluntary, and its applicability and suitability for any particular use, including any patent infringement arising therefrom, is the sole responsibility of the user."

SAE reviews each technical report at least every five years at which time it may be revised, reaffirmed, stabilized, or cancelled. SAE invites your written comments and suggestions.

Copyright © 2022 SAE International

All rights reserved. No part of this publication may be reproduced, stored in a retrieval system or transmitted, in any form or by any means, electronic, mechanical, photocopying, recording, or otherwise, without the prior written permission of SAE.

**TO PLACE A DOCUMENT ORDER:**    **Tel: 877-606-7323 (inside USA and Canada)**  
   **Tel: +1 724-776-4970 (outside USA)**  
   **Fax: 724-776-0790**  
   **Email: CustomerService@sae.org**  
   **http://www.sae.org**

**For more information on this standard, visit**  
<https://www.sae.org/standards/content/ARP5526F/>

3.6	Movable Aisle Armrests .....	14
3.6.1	Applicable Policy and Regulations .....	14
3.6.2	Recommended Practice .....	15
3.7	Baggage Bar Loading and Retention of Items Under the Seat .....	15
3.7.1	Applicable Policy and Regulations .....	15
3.7.2	Recommended Practice .....	15
3.8	Seat Safety Placards .....	18
3.8.1	Applicable Policy and Regulations .....	18
3.8.2	Recommended Practice .....	19
3.9	Literature Pocket Stowage Capacity .....	19
3.9.1	Applicable Policy and Regulations .....	19
3.9.2	Recommended Practice .....	19
3.10	Seat Back Mounted Tray Table Latch Inadvertent Operation .....	21
3.10.1	Applicable Policy and Regulations .....	21
3.10.2	Recommended Practice .....	22
3.11	Pinch Hazards .....	22
3.11.1	Applicable Policy and Regulations .....	22
3.11.2	Recommended Practice .....	23
3.12	Sharp Edges .....	28
3.12.1	Applicable Policy and Regulations .....	28
3.12.2	Recommended Practice .....	28
3.13	Evaluation of Surfaces within Head Strike Zone .....	28
3.13.1	Applicable Policy and Regulations .....	28
3.13.2	Recommended Practice .....	28
3.14	Seat Features Adjusted with/without Tools .....	32
3.14.1	Applicable Policy and Regulations .....	32
3.14.2	Recommended Practice .....	33
3.15	Legrest and Footbar Retention .....	33
3.15.1	Applicable Policy and Regulations .....	33
3.15.2	Recommended Practice .....	34
3.16	Emergency Escape Path Marking .....	34
3.16.1	Applicable Policy and Regulations .....	34
3.16.2	Recommended Practice .....	34
3.17	Rotating and Translating Armrests .....	35
3.17.1	Applicable Policy and Regulations .....	35
3.17.2	Recommended Practice .....	35
3.18	Electrically Actuated Features .....	36
3.18.1	Applicable Policy and Regulations .....	36
3.18.2	Recommended Practice .....	36
3.18.3	Further Information .....	46
3.19	Crew Size .....	47
3.19.1	Applicable Policy and Regulations .....	47
3.20	Occupant Height .....	47
3.20.1	Recommended Practice .....	47
3.21	Occupant Size .....	48
3.21.1	Applicable Policy and Regulations .....	48
3.21.2	Recommended Practice .....	48
3.22	Attendant Step .....	48
3.22.1	Applicable Policy and Regulations .....	48
3.22.2	Recommended Practice .....	48
3.23	Wear and Deterioration .....	50
3.23.1	Applicable Policy and Regulations .....	50
3.23.2	Recommended Practice .....	50
3.24	Fire Protection Requirements .....	50
3.24.1	Applicable Policy and Regulations .....	50
3.24.2	Recommended Practice .....	50
3.25	Anti-Rattle Device .....	51
3.25.1	Applicable Policy and Regulations .....	51
3.25.2	Recommended Practice .....	51

3.26	Recline Egress .....	51
3.26.1	Applicable Policy and Regulations .....	51
3.26.2	Recommended Practice .....	51
3.27	Abuse Loads for Secondary Structures .....	52
3.27.1	Applicable Policy and Regulations .....	52
3.27.2	Recommended Practice .....	52
3.28	Fatigue Life Criteria .....	53
3.28.1	Applicable Policy and Regulations .....	53
3.28.2	Recommended Practice .....	53
3.29	Legrest and Footrest/Footbar Definition .....	53
3.29.1	Applicable Policy and Regulations .....	53
3.29.2	Recommended Practice .....	54
3.30	Object Entrapment .....	55
3.31	Life Vest Stowage Ease of Search .....	55
3.31.1	Application Policy and Regulations .....	55
3.31.2	Recommended Practice .....	56
3.32	Manual Override for TTL Position of Electrically Operated Seats .....	58
3.32.1	Applicable Policy and Regulations .....	58
3.32.2	Recommended Practice .....	59
3.33	Environmentally Preferable Material .....	59
3.33.1	Applicable Policy and Regulations .....	59
3.33.2	Recommended Practice .....	59
4.	NOTES .....	60
4.1	Revision Indicator .....	60
Figure 1	Seat belt misalignment .....	8
Figure 2	Seat belt misalignment .....	9
Figure 3	An example of a design to avoid .....	9
Figure 4	An example of a design to avoid .....	10
Figure 5	An example of a design to avoid .....	10
Figure 6	An example of a design to avoid .....	11
Figure 7	Seat Y-belt misalignment .....	11
Figure 8	Belt cover non-permanent attachment .....	12
Figure 9	Economy seat - planes defining the boundaries of underseat stowage .....	16
Figure 10	All other seats - planes defining the boundaries of underseat stowage .....	16
Figure 11A	Acceptable angle for upper surface of underseat stowage volume .....	18
Figure 11B	Acceptable complex shape for upper surface of underseat stowage volume .....	18
Figure 12	Literature pocket size recommendations .....	20
Figure 13	External pockets .....	21
Figure 14	This is the hinge for an in-arm video display. It is an example of a type 1a score from the injury potential analysis table. ....	24
Figure 15	This is the arm cap for an in-arm tray table seat. It is an example of a type 1a score from the injury potential analysis table. ....	25
Figure 16	This is a hinge for an in-arm tray table. It is an example of a type 1a score from the injury potential analysis table. ....	25
Figure 17	This is a spring-mounted stowage box door. It is an example of a type 4a score from the injury potential analysis table based on spring force potential. ....	26
Figure 18	This is an aft mounted food tray table. It is an example of a type 1a score from the injury potential analysis table. ....	26
Figure 19	This is the hinge point for a rotating armrest. It is an example of a type 2b score from the injury potential analysis table. ....	27
Figure 20A	Seat back sharp edges head strike zone width (HIC compliant) .....	29
Figure 20B	Seat back sharp edges head strike zone upper and lower height (HIC compliant) .....	30
Figure 21	Head strike zone definition (non-HIC compliant) .....	31
Figure 22	Hazard determination chart .....	39
Figure 23	Legrest measurement points for moving parts .....	40
Figure 24	Armrest measurement points for moving parts .....	41
Figure 25	Seat back measurement points for moving parts .....	41
Figure 26	Force measurement example .....	42

Figure 27	Acceptable foot insertion into stirrup-type step.....	49
Figure 28	Typical economy class step.....	49
Figure 29	Typical first/business class step.....	49
Figure 30	Load directions for rotating aisle armrest.....	53
Figure 31	Seat description.....	54
Figure 32	Evaluation object shape.....	57
Figure 33	Example of overlapping surfaces.....	57
Figure 34	Example of door larger than container opening.....	58
Figure 35	Example of hole in inner container surface.....	58
Table 1	Minimum passenger aisle width.....	15
Table 2	Injury potential analysis.....	23
Table 3	Maximum force values.....	40
Table 4	Hazard level evaluation lbf (N = Newtons).....	43
Table 5	Examples of hazard modifying factor values.....	45
Table 6	Hazard value and recommended actions.....	45
Table 7	CAESAR anthropometric database sitting and standing height.....	48
Table 8	Typical small parts.....	50
Table 9	Seat secondary structure abuse loads.....	52
Table 10	Seat secondary structure fatigue life.....	53

## 1. SCOPE

This SAE Aerospace Recommended Practice (ARP) documents a common understanding of terms, compliance issues, and design criteria to facilitate certification of seat installations specific to Part 25 aircraft. This ARP provides general guidance for seats to be installed in Part 23 aircraft and Parts 27 and 29 rotorcraft and does not specify specific designs or design methods for such certification.

## 2. APPLICABLE DOCUMENTS

The following publications form a part of this document to the extent specified herein. The latest issue of SAE publications shall apply. The applicable issue of other publications shall be the issue in effect on the date of the purchase order. In the event of conflict between the text of this document and references cited herein, the text of this document takes precedence. Nothing in this document, however, supersedes applicable laws and regulations unless a specific exemption has been obtained.

### 2.1 SAE Publications

Available from SAE International, 400 Commonwealth Drive, Warrendale, PA 15096-0001, Tel: 877-606-7323 (inside USA and Canada) or +1 724-776-4970 (outside USA), [www.sae.org](http://www.sae.org).

AFRL-HE-WP-TR-2002-0170 CAESAR: Summary Statistics for the Adult Population (ages 18-65) of the United States of America

AS5678 Passive RFID Tags Intended for Aircraft Use

AS8049 Performance Standard for Seats in Civil Rotorcraft, Transport Aircraft, and General Aviation Aircraft

### 2.2 NAS Publications

Available from Aerospace Industries Association, 1000 Wilson Boulevard, Suite 1700, Arlington, VA 22209-3928, Tel: 703-358-1000, [www.aia-aerospace.org](http://www.aia-aerospace.org).

NAS809 Specification - Aircraft Seats and Berths

### 2.3 CFR Publications

Available from the United States Government Printing Office, 732 North Capitol Street, NW, Washington, DC 20401, Tel: 202-512-1800, [www.gpo.gov](http://www.gpo.gov).

Code of Federal Regulations Title 14 Part 23 (14 CFR Part 23) Airworthiness Standards: Normal, Utility, and Acrobatic Category Airplanes

Code of Federal Regulations Title 14 Part 25 (14 CFR Part 25) Airworthiness Standards: Transport Category Airplanes

Code of Federal Regulations Title 14 Part 27 (14 CFR Part 27) Airworthiness Standards: Normal Category Rotorcraft

Code of Federal Regulations Title 14 Part 29 (14 CFR Part 29) Airworthiness Standards: Transport Category Rotorcraft

Code of Federal Regulations Title 14 Part 121 (14 CFR 121) Certification and Operations: Domestic, Flag, and Supplemental Air Carriers and Commercial Operators of Large Aircraft

### 2.4 FAA Publications

Available from Federal Aviation Administration, 800 Independence Avenue, SW, Washington, DC 20591, Tel: 866-835-5322, [www.faa.gov](http://www.faa.gov).

AC 25-17A CHG 1 Transport Airplane Cabin Interiors Crashworthiness Handbook

AC 25.785-1B	Flight Attendant Seat and Torso Restraint System Installations
ANM-04-115-28	Subject: Policy Statement on an Unreliable Design of Seat Belt Attachment, Fittings on Passengers' Seats and Compliance with § 25.601
ANM-03-115-31	Policy Statement on Conducting Component Level Tests to Demonstrate Compliance with §§ 25.785(b) and (d)
PS-ANM100-2003-10019	Subject: Policy Statement on Evaluating a Seat Armrest Cavity for a Potential Fire Hazard
PS-ANM-25.853-01-R2	Subject: Flammability Testing of Interior Materials

Special Airworthiness Information Bulletin (SAIB) NM-04-37, issued December 22, 2003, recommends that a specific design of seat belt attachment fitting be replaced with an improved design fitting.

## 2.5 Civil Aerospace Medical Institute

Available from the United States Government Printing Office, 732 North Capitol Street, NW, Washington, DC 20401, Tel: 202-512-1800, [www.gpo.gov](http://www.gpo.gov).

DOT/FAA/AM-03/9	Human Factors Associated with the Certification of Airplane Passenger Seats: Life Preserver Retrieval
-----------------	---

## 2.6 NASA Publications

NASA Technical Services, NASA STI Program STI Support Services, Mail Stop 148, NASA Langley Research Center, Hampton, VA 23681-2199, 757-864-9658, Fax: 757-864-6500, <http://ntrs.nasa.gov/>.

NASA-STD-3000 Vol. I	Man Systems Integration Standards Rev. B, NASA Johnson Space Center, Houston, TX, 1995.
----------------------	---

## 2.7 UL Publications

Available from UL, 333 Pfingsten Road, Northbrook, IL 60062-2096, Tel: 847-272-8800, [www.ul.com](http://www.ul.com).

UL 1439	Tests for Sharpness of Edges on Equipment
---------	---

## 2.8 RTCA Publications

Available from RTCA, Inc., 1150 18th Street, NW, Suite 910, Washington, DC 20036, Tel: 202-833-9339, [www.rtca.org](http://www.rtca.org).

DO-160G	Environmental Conditions and Test Procedures for Airborne Equipment
---------	---

## 3. RECOMMENDED PRACTICES

FAR references can be considered valid across aircraft categories: 14 Code of Federal Regulations Parts 23, 25, 27, and 29.

### 3.1 Seat Back Handhold in Turbulence

#### 3.1.1 Applicable Policy and Regulations

#### 14 CFR Part 25.785 (j) Amendment 25-88

If the seat backs do not provide a firm handhold, there must be a handgrip or rail along each aisle to enable persons to steady themselves while using aisles in moderately rough air.

#### AC 25-1 CHG 1 par. 81.b (6) Crashworthiness Handbook

The seat back may serve as a firm handhold. Since many seats are capable of breaking over, the breakover load must be adequate to be considered firm. A load of 25 pounds (111 N) minimum, acting horizontally, is considered adequate when applied at the top center of the seat back.

### 3.1.2 Recommended Practice

A handhold is defined as a means of providing a hand hold support for a person standing upright in an aisle during flight. If an adequate supplemental rail or handgrip is not provided in the interior, seat backs may be used as the handhold so long as they are spaced sufficiently close together to be within reach for an occupant using the aisle. For that purpose, a seat pitch of 65 inches (165 cm) or less is considered adequate in a typical commercial transport aircraft configured with forward or rearward facing passenger seats positioned along an aisle. Due to the unique and customized interior arrangement of forward, sideward, or rearward facing passenger seats in business/private transport aircraft (not for hire), these configurations should be assessed individually. Divan seating and side facing seats do not normally place the seat back where it can be effectively used as a handhold.

To act as a handhold, the upper aisle-side corner of the seat back should provide either a surface to grip or push against. A seat back used as a handhold should not break over when a force of 25 pounds (111 N) in a direction perpendicular to the seat back is applied at the top center of the seat back. Seat backs with head rests that telescope more than 3 inches (7.6 cm) above the seat back may be used for a handhold if, in addition to all other requirements, no portion of the head rest, e.g., bendable ears and/or tilting head rest, can be moved more than 7 inches (17.8 cm) before a 25 pound (111 N) resistive force is met.

The seat back handhold should be at least 33 inches (84 cm) above the floor, even if the seat back is reclined.

## 3.2 Seat Belt Misalignment/Disengagement

### 3.2.1 Applicable Policy and Regulations

#### 14 CFR Part 25.601

General.

The airplane may not have design features or details that experience has shown to be hazardous or unreliable. The suitability of each questionable design detail and part must be established by tests.

#### 14 CFR Part 25.562 Amendment 25-64

(a) The seat and restraint system in the airplane must be designed as prescribed in this section to protect each occupant during an emergency landing condition when:

- (1) Proper use is made of seats, safety belts, and shoulder harnesses provided for in the design.
- (2) The occupant is exposed to loads resulting from the conditions prescribed in this section.

#### FAA Policy Memo ANM-04-115-28

Policy Statement on an Unreliable Design of Seat Belt Attachment Fittings on Passenger's Seats and Compliance with § 25.601.

#### NAS 809

When anchorages for safety belts are provided, they should be of a type which will permit self-aligning of the belt or fitting.

### 3.2.2 Recommended Practice

#### 3.2.2.1 Restraint

The term restraint in this section refers to any strap, webbing, or similar device designed to secure a person in an aircraft with the intention of minimizing injury, including all buckles or other fasteners, and all integral hardware.

Seatbelt misalignment is a condition where the seatbelt and/or shackle is positioned to give the impression that the belt has been properly tightened, when in fact there is slack in the system or the shackle is positioned so that it will not carry the force generated in an emergency landing or turbulence condition.

The seat belt installation should provide a self-orienting (free rotation and self-alignment) line of pull for the belt, minimize the possibility of inadvertent disconnection, and be designed to minimize an incorrect installation.

The seat belt installation should not appear to the belted occupant to be properly adjusted (snug) while there is significant (1 inch [2.54 cm] or more) slack in the system which may pay out in an emergency landing situation. For example, the belt installation should not be able to be caught between seat features such that the occupant would not know there was slack in the belt which may allow the occupant to slide forward during emergency landing or turbulence.

To evaluate the installed seat belt for misalignment, the seat should be positioned in its taxi, takeoff, and landing condition. Installations on seats having bottom cushions that can be removed or incorrectly repositioned without tools should be evaluated with the cushions installed, removed, and incorrectly repositioned. The belt and shackle combination should be manipulated with one hand in an attempt to place the restraint in a non-design configuration where it could carry the seatbelt adjustment forces. Particular effort should be made to place the restraint in a position that the restraint forces would not be applied to the hook of the shackle in the same manner as they would be applied in a straight tension pull on the belt. Attempts should be made with the restraint in its normal shape, a single twist of the webbing and/or a single fold of the webbing. Typical areas around the restraint shackle that should be checked are the plastic shrouding around the armrest, the hydraulic seat recline device, the seat pan, anti-rotation brackets/stops, seat pan supports, and exposed fasteners. If a condition of potential misalignment is identified, the seatbelt and shackle, in that condition, should be loaded by a restorative force of 5 pounds (22 N) applied through the belt in the direction that it would be loaded in the emergency landing or turbulence situation. If the load is carried in the misaligned condition, the design is unacceptable. The examples in 3.2.3 illustrate various misalignment conditions that have been found to be unacceptable, as indicated. These examples are not intended to be all-inclusive.

To evaluate the belt for inadvertent disengagement, where disengagement is defined as the separation of the restraint's attachment fitting from the seat structure, the belt should be tested in all orientations with the seat in the taxi, takeoff, and landing conditions with the seat cushions installed. Interaction of belts in adjacent seats, where the belts could be inadvertently crossed and used by occupants in those adjacent seats, must be evaluated for the possibility of disengagement.

### 3.2.3 Examples

Examples of various causes of seat belt misalignment are illustrated in Figures [1](#) and [2](#).

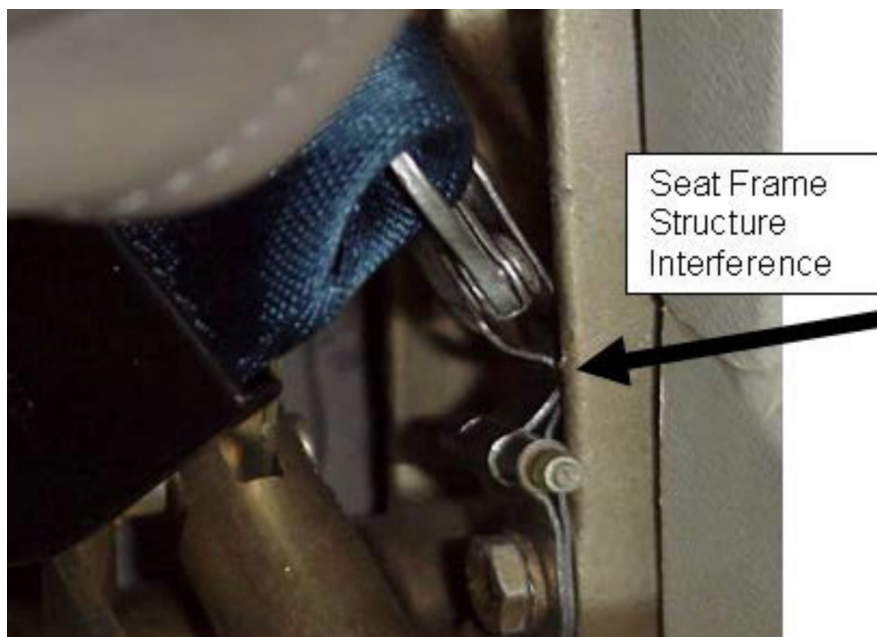

**Figure 1 - Seat belt misalignment**



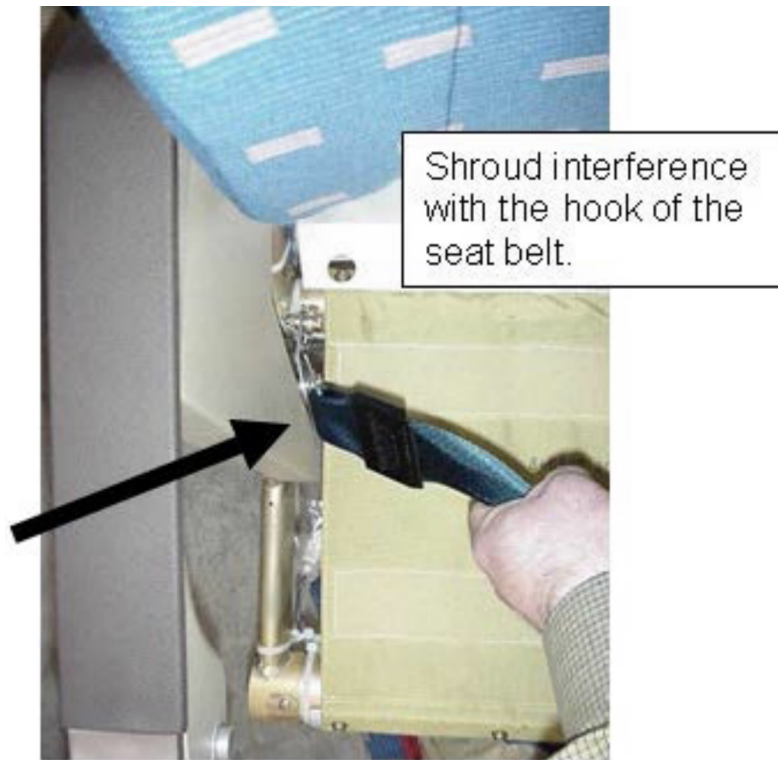

**Figure 2 - Seat belt misalignment**

Examples of designs to avoid are illustrated in Figures [3](#), [4](#), [5](#), and [6](#).



**Figure 3 - An example of a design to avoid**



**Figure 4 - An example of a design to avoid**

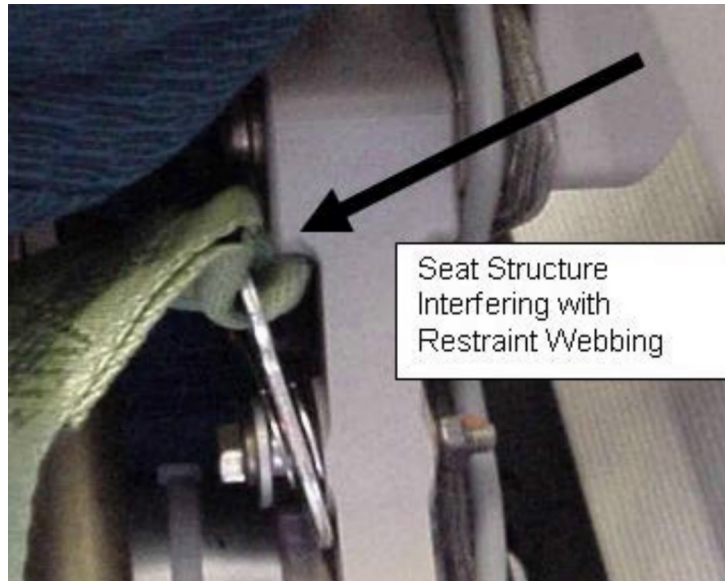

**Figure 5 - An example of a design to avoid**

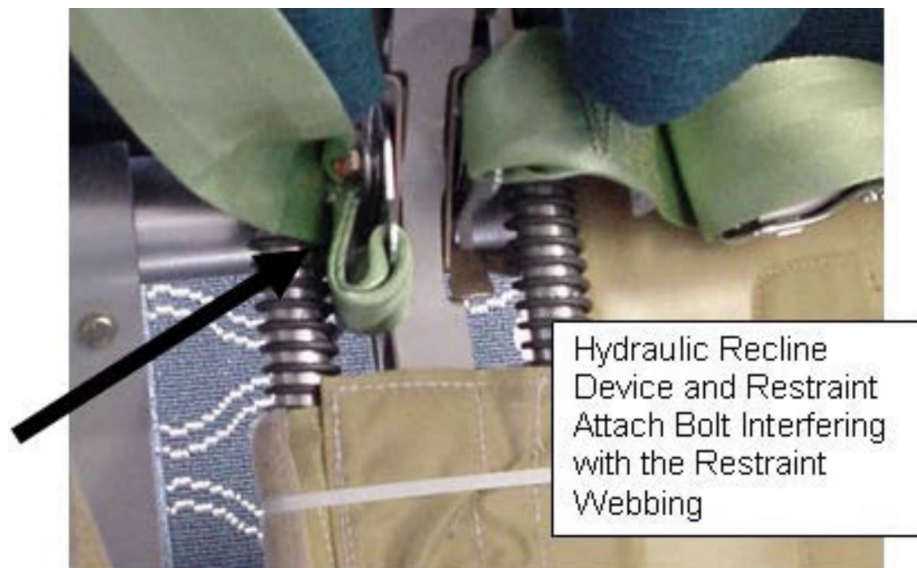

**Figure 6 - An example of a design to avoid**

### 3.2.4 Y-Belts

Consideration should also be given to seat belt misalignment when Y-belts are installed. [Figure 7](#) demonstrates a non-compliant installation where the belt can be easily looped through the Y-belt opening.

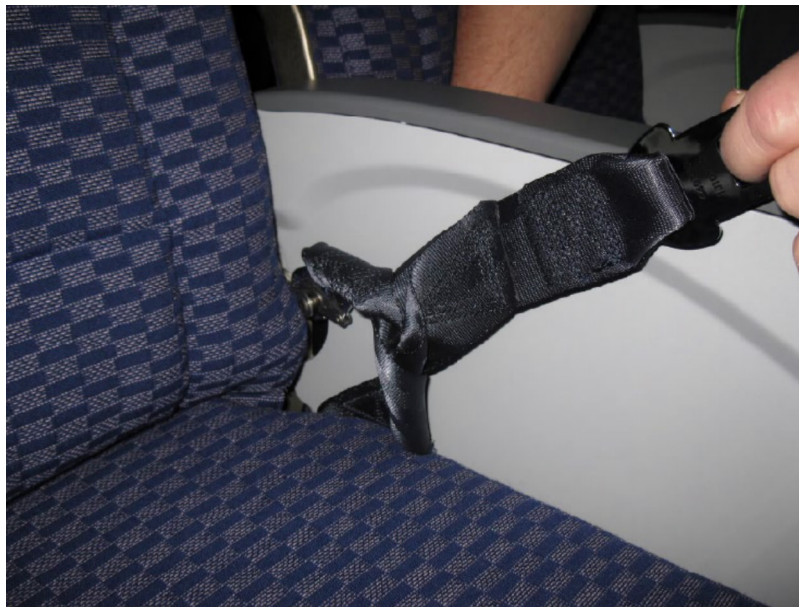

**Figure 7 - Seat Y-belt misalignment**

One method to control such a situation is the addition of a Y-belt cover. Not all Y-belts require such a cover, depending on the construction of the seat, interface with the belt itself, cushion location, and belt anchor point. If a belt cannot be easily looped inside the Y-belt opening using the test method prescribed in 3.2.2, then a cover is not required.

When a Y-belt cover is installed, it is recommended that the cover use a permanent attachment rather than, for instance, a snap as shown in [Figure 8](#). This is to ensure that the cover is not inadvertently removed or misaligned during normal passenger movement or maintenance.





**Figure 8 - Belt cover non-permanent attachment**

### 3.3 Life Vest/Life Jacket Retrieval

#### 3.3.1 Applicable Policy and Regulations

##### 14 CFR Part 25.1411 Amendment 25-116

- (f) Life preserver stowage provisions. The stowage provisions for life preservers described in Sec. 25.1415 must accommodate one life preserver for each occupant for which certification for ditching is requested. Each life preserver must be within easy reach of each seated occupant.

##### 14 CFR Part 25.1541

- (a) The airplane must contain:
- (1) The specified markings and placards; and
  - (2) Any additional information, instrument markings, and placards required for the safe operation if there are unusual design, operating, or handling characteristics.
- (b) Each marking and placard prescribed in the previous paragraph:
- (1) Must be displayed in a conspicuous place; and
  - (2) May not be easily erased, disfigured, or obscured.

##### 14 CFR Part 27.1411 Amendment 27-11

- (a) Required safety equipment to be used by the crew in an emergency, such as flares and automatic life raft releases, must be readily accessible.
- (b) Stowage provisions for required safety equipment must be furnished and must:
- (1) Be arranged so that the equipment is directly accessible, and its location is obvious; and
  - (2) Protect the safety equipment from damage caused by being subjected to the inertia loads specified in Sec. 27.561.

14 CFR Part 29.1411

(f) Life preservers. Each life preserver must be within easy reach of each occupant while seated.

### 3.3.2 Recommended Practice

When required, life vest stowage should be provided at each seating position in accordance with 14 CFR 25.1411 and 25.1541. If a seat can be occupied for taxi, takeoff, and landing, while facing in more than one direction, the life vest stowage provisions should be accessible for each of these positions. The life vest container should be located such that it does not hinder, in any way, the retrieval of the life vest by a seated and belted occupant. FAA report DOT/FAA/AM-03/9 provides general guidance to assist in evaluating the life preserver installation features associated with the easy reach requirements in FAA regulations. At a minimum, the life vest container should be designed and located such that the following requirements are met:

- a. The life vest location is readily apparent.
- b. Life vest stowage should be located such that each occupant has access to a life vest, and the life vest is within easy reach of each seated and belted occupant in the aircraft during taxi, takeoff, or landing.
- c. The life vest is restrained under all applicable loading conditions.
- d. The container and opening are correctly sized for the specified life vest.
- e. The container opening is located to allow the life vest to be readily removed by the seated and belted occupant.
- f. The method of opening is usable over a range of angles (e.g., unidirectional straps, snaps, etc., that can only be used by pulling one direction should be avoided). When pull straps are used, they should not be difficult to reach or operate. They should operate from all reasonably anticipated angles that would be used by a seated and belted occupant as limited by structure, cushions, and seat pitch.
- g. The retrieval path of the life vest should be free of obstructions due to seat or aircraft components and/or pouch movement (e.g., legs, cushions, baggage bars, shrouds, etc.).
- h. The retention device should not allow the vest to come free during a heavy landing, normal seat activity (e.g., stowage and removal of under seat baggage), takeoff, or other aircraft maneuver.
- i. Normal seat operation should not sweep the pull strap into an unreachable location.
- j. The life vest container should not present any sharp edges or points that could damage the life vest or cause injury.
- k. The location of pull straps is recommended to be adequately marked per 3.8. Pull straps are recommended to be red or labeled "PULL" or "PULL FOR LIFE VEST" in contrasting color.
- l. Life vest retrieval should not be prevented by constricting elastic at the life vest container opening.

### 3.3.3 Life Vests in Legrests Considerations

All requirements under 3.3.2 are applicable with the following exemptions:

\* Retrieval of life vest

Per 3.3.2 g. plus, consideration of footbars which should not impact on the pull strap or vest accessibility and should be evaluated in all positions to ensure it can be readily moved out of the way.

\* Inadvertent opening

Per 3.3.2 h. plus, life vest container shall not be susceptible to inadvertent opening by a seated occupant's foot or feet.

\* Effect of static and dynamic deformations on life vest retrievability

Distance between life vest container post deformation (plastic deformation only) and airplane floor should be such that the retrieval of the life vest will not be obstructed. Seat tracks and track covers should be considered.

### 3.4 Friction Fit Components

#### 3.4.1 Applicable Policy and Regulations

##### 14 CFR Part 25.789 Amendment 25-46

Retention of items of mass in passenger and crew compartments and galleys.

(a) Means must be provided to prevent each item of mass (that is part of the airplane type design) in a passenger or crew compartment or galley from becoming a hazard by shifting under the appropriate maximum load factors corresponding to the specified flight and ground load conditions, and to the emergency landing conditions of Sec. 25.561(b).

#### 3.4.2 Recommended Practice

The use of friction fit as the sole method of restraint for items of mass (with the exception of ash trays) is not recommended.

A friction fit item is one that is restrained only by static friction between two or more flat or curved surfaces in direct contact with each other. Items restrained by mechanical fasteners such as screws, bolts, nuts, hook and loop tape, hooks, springs, detents, rivets, or similar devices are not considered friction fit items.

### 3.5 Fire Containment - Cavity Fully Enclosed/Open

#### 3.5.1 Applicable Policy and Regulations

##### 14 CFR Part 25.601

General.

The airplane may not have design features or details that experience has shown to be hazardous or unreliable. The suitability of each questionable design detail and part must be established by tests.

#### 3.5.2 Recommended Practice

In cases where seats are designed with armrest cavities (that are typically used to hold tray tables and/or video monitors), the FAA policy memo PS-ANM100-2003-10019 should be used to determine if the cavity should be fully enclosed or have an open bottom.

The FAA performed testing that included evaluation of armrest cavities with different levels of ventilation. Federal Aviation Administration Report DOT/FAA/AR-TN02/105, "Burning Behavior within a Seat Armrest Cavity," dated September 2002, documents the results of fire tests conducted to examine the characteristics of several fire scenarios that could occur in an armrest cavity and the fire-containment capability of the cavity. In all the tests conducted with actual seat armrests, the fire self-extinguished, the armrest material did not ignite, and the fire was contained within the armrest cavity.

The FAA reviewed the practice of requiring seat armrest cavities to either be completely enclosed or have an open bottom. They determined that armrest cavities do not constitute a significant fire hazard regardless of whether or not these conditions are met. Accordingly, the armrest cavity may be open or closed to any degree and will not be hazardous under § 25.601.

### 3.6 Movable Aisle Armrests

#### 3.6.1 Applicable Policy and Regulations

##### 14 CFR Part 25.789 Amendment 25-46

Retention of items of mass in passenger and crew compartments and galleys.

(a) Means must be provided to prevent each item of mass (that is part of the airplane type design) in a passenger or crew

compartment or galley from becoming a hazard by shifting under the appropriate maximum load factors corresponding to the specified flight and ground load conditions, and to the emergency landing conditions of Sec. 25.561(b).

#### 14 CFR Part 25.815 Amendment 25-38

Width of aisle.

The passenger aisle width at any point between seats must equal or exceed the values in [Table 1](#):

**Table 1 - Minimum passenger aisle width**

Passenger Seating	Minimum Passenger Aisle Width (inches)	
	Less than 25 Inches (63.5 cm) from Floor	25 Inches (63.5 cm) and More from Floor
10 or less	12 (30.5 cm)	15 (38.1 cm)
11 through 19	12 (30.5 cm)	20 (50.8 cm)
20 or more	15 (38.1 cm)	20 (50.8 cm)

### 3.6.2 Recommended Practice

In cases where moveable passenger seat aisle armrests intrude into the required passenger aisle width when deployed, they shall be retained in the taxi, takeoff, and landing position during normal operation.

If the armrest is allowed to move, one of the below criteria should be applicable:

- \* Return to the taxi, takeoff, and landing position by a positive means (e.g., spring assisted) without requiring the assistance of a passenger or attendant.
- \* Be retained in the taxi, takeoff, and landing position by a discreet mechanical means (e.g., a latch) that is hidden or not obvious to a person in the seat or in nearby seats or standing in the aisle. The latch shall not allow inadvertent or accidental operation under normal use of the seat.
- \* If the armrest is removable, the armrest shall be retained in the taxi, takeoff, and landing position by a discreet mechanical means (e.g., a latch) that is hidden or not obvious to a person in the seat or in nearby seats or standing in the aisle. The latch shall not allow inadvertent or accidental operation under normal use of the seat.

NOTE: In case the armrest is removed, there shall be no sharp edges.

### 3.7 Baggage Bar Loading and Retention of Items Under the Seat

#### 3.7.1 Applicable Policy and Regulations

##### 14 CFR Part 25.787 Amendment 25-51

- (b) There must be a means to prevent the contents in the compartments from becoming a hazard by shifting, under the loads specified in item a. of this section.

#### AC 25-1 CHG 1 Para 102(b)(2)

Standard design criteria for underseat baggage restraint.

### 3.7.2 Recommended Practice

#### 3.7.2.1 Definition of Underseat

Regardless of seat installation angle, any baggage stowed in an underseat compartment must be restrained when subject to the inertia load factors defined in 14 CFR 25.561, with the exception of the aft direction.

The maximum volume available for underseat stowage is defined below in Figures 9 and 10 for forward-facing seats is shown below. The six planes are defined as follows:

Plane 1 - The floor water line (or pallet/plinth waterline if appropriate) without floor covering.

Plane 2 - A horizontal plane 18 inches (46 cm) above plane 1.

Plane 3 - The aft side of the forward-most station line of the baggage restraint device.

Plane 4 - The aft-most station of the floor fitting (for typical economy seats) or aft-most station line of seatback plane or shell when the seat is in position for taxi, take-off, and landing (for premium class seats).

Plane 5 - Right-most butt line of armrest.

Plane 6 - Left-most butt line of armrest.

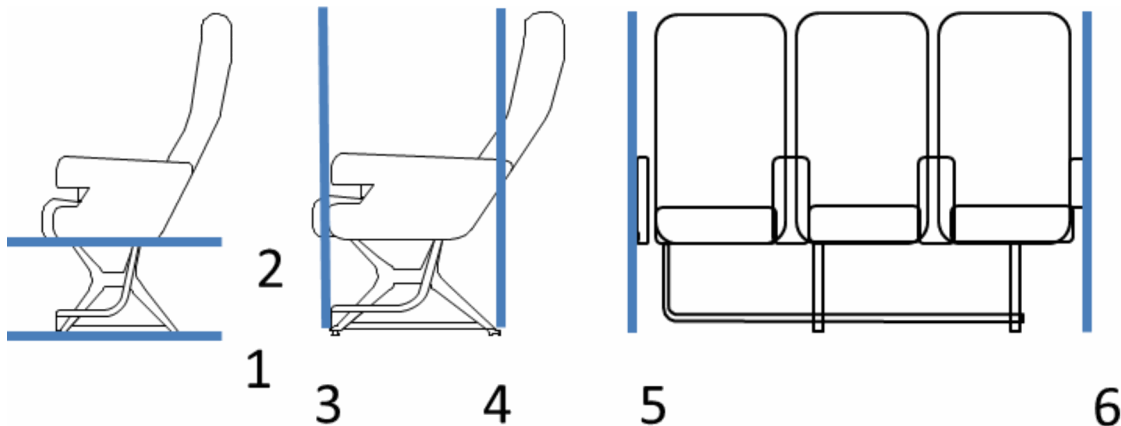

**Figure 9 - Economy seat - planes defining the boundaries of underseat stowage**

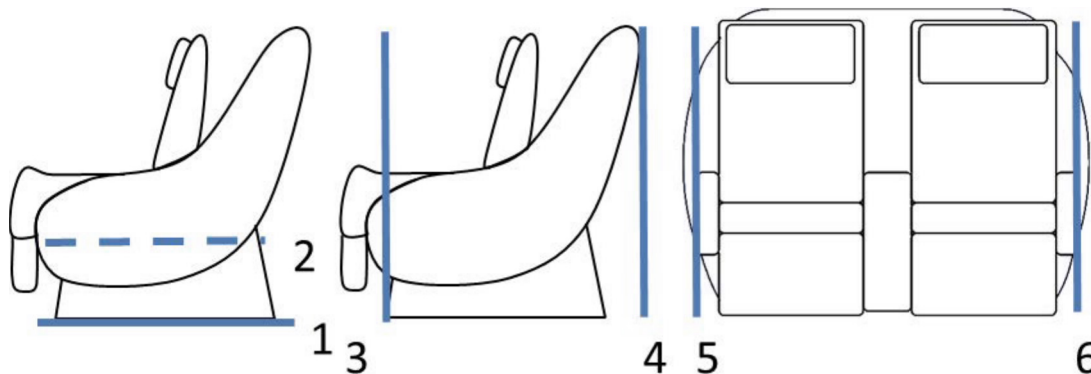

**Figure 10 - All other seats - planes defining the boundaries of underseat stowage**

Oblique, side, and aft facing seats do not typically possess the same underseat baggage volumes as forward-facing seats, and the underseat baggage volume for each of these seats must be considered separately using the above planes as guidelines.

The same planes can be defined for seat systems containing furniture, such as ottomans. These requirements are also applicable to seat furniture. For seat furniture, plane 4 is the aft-most station line of furniture.

Note that directions and load factors are defined relative to the aircraft axes rather than the seat axes.

### 3.7.2.2 Underseat Stowage Requirements

Any volume inside the six stowage planes can be defined as underseat stowage if sufficient retention is shown (except in aft direction).

Each passenger seat under which baggage is allowed to be stowed shall be fitted with a means to prevent articles or baggage stowed under it from sliding forward or sideward (into the aisle or exit area).



AC 25-17A CHG 1 Sections 102 through 104 provide means of compliance for the substantiation of underseat stowage.

Although it is expected that the underseat baggage volume will store a variety of items, a standard bag, or representative mass with the dimensions of 3 x 12 x 17 inches (7.6 x 30.5 x 43.0 cm) and a weight of 20 pounds (9.0 kg), shall be used during substantiation of the underseat baggage restraint.

Installations that deviate from that guidance of AC 25-17A CHG 1 should restrain the baggage under the required loading conditions and should accommodate a step/abuse load of 300 pounds (1334 N) without failure (where applicable). The baggage restraint may yield and load the floor structure during step load testing. The baggage restraint may be substantiated by test or rational analysis.

The criteria below are applicable to the designated underseat stowage volumes defined for each seat. For seats that use shrouds to reduce the available volume, the intent is that the criteria apply to the available baggage volume.

- a. The baggage restraints shall restrain the underseat baggage within the underseat volume with the exception of the aft direction with respect to the aircraft. The standard bag may protrude aft of plane 4. Downward restraint is usually provided by the aircraft floor, but may be provided by the seat.
- b. The dimensions of the baggage restraint structure shall be as follows:
  1. The forward baggage restraint shall not extend beyond planes 5 and 6 in Figures [9](#) and [10](#) (see also items c and d).
  2. The side baggage restraint (left and right) shall extend at least 8.75 inches (22.2 cm) from plane 3 in Figures [9](#) and [10](#).
  3. The upward baggage restraint shall extend at least 8.75 inches (22.2 cm) from plane 3 in Figures [9](#) and [10](#) and extend to cover the distance defined in item 1. above.
  4. If the downward restraint is part of seat structure (i.e., not the aircraft floor), the restraint shall extend at least 8.75 inches (22.2 cm) from plane 3 in Figures [9](#) and [10](#) and extend to cover the distance defined in item 1.
- c. Discontinuities in the baggage restraint, as may be found when two double units make up a quad seat or when the inboard end of the baggage restraint is outboard of the aisle shall not have a gap greater than 3 inches (7.6 cm).
- d. The gap between the outboard end of the baggage restraint and the sidewall shall be no greater than 5 inches (12.7 cm).
- e. Seat or furniture structure intended to react loads generated by the underseat baggage in the up or down directions must fully restrain the stowage item. The design of these surfaces must not be such that a stowage item reacting to the prescribed accelerations is ejected toward the occupant.

The upper surface of the stowage volume shall be horizontal or angled 15 degrees or less to the floor waterline (angle A as shown in Figure [11A](#)).

For a complex upper surface of the stowage volume, the surface shall be angled 15 degrees or less to the floor waterline to a point that is half the distance from planes 3 to 4, or greater (point B as shown in Figure [11B](#)). The angle of the complex surface aft of that point may be greater than 15 degrees.

See 3.7.2.1, Figures [9](#) and [10](#) for definition of planes 3 and 4.

- f. Any baggage restraint that is not rigid, such as a net enclosure or a thin plastic seat shroud, shall not encroach into the minimum aisle, passageway, or cross aisle, when fully extended under the prescribed loads. Care must be taken when using non-rigid baggage restraints to ensure that floor proximity emergency escape path lighting or photo luminescent strips cannot be obscured.
- g. When the baggage restraint is a bar, it shall be at least 0.75 inch (1.9 cm) in height.
- h. The bottom of the baggage bar shall be no more than 2.5 inches (6.4 cm) above the floor level. The top of the baggage bar shall be no less than 3 inches (7.6 cm) above the floor level. Each of these dimensions must include an allowance for the floor covering.

- i. Baggage bars operated by lifting the bar up from the front of the seat must have a latch indicator clearly visible from the aisle when the latch is locked.

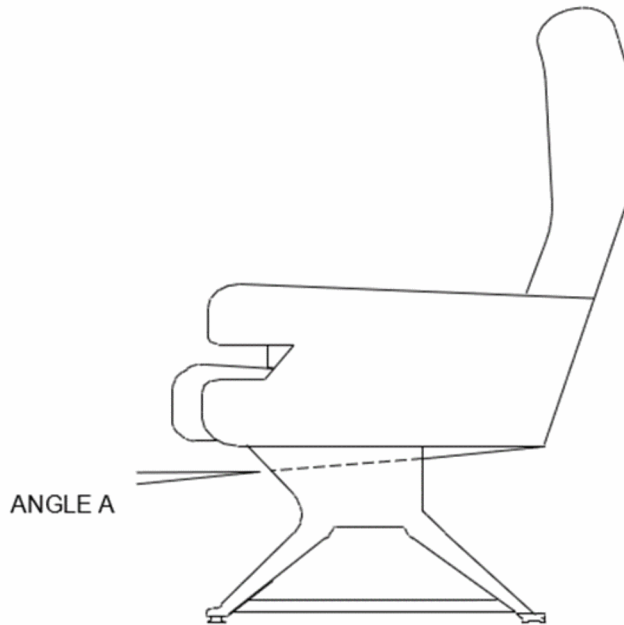

**Figure 11A - Acceptable angle for upper surface of underseat stowage volume**

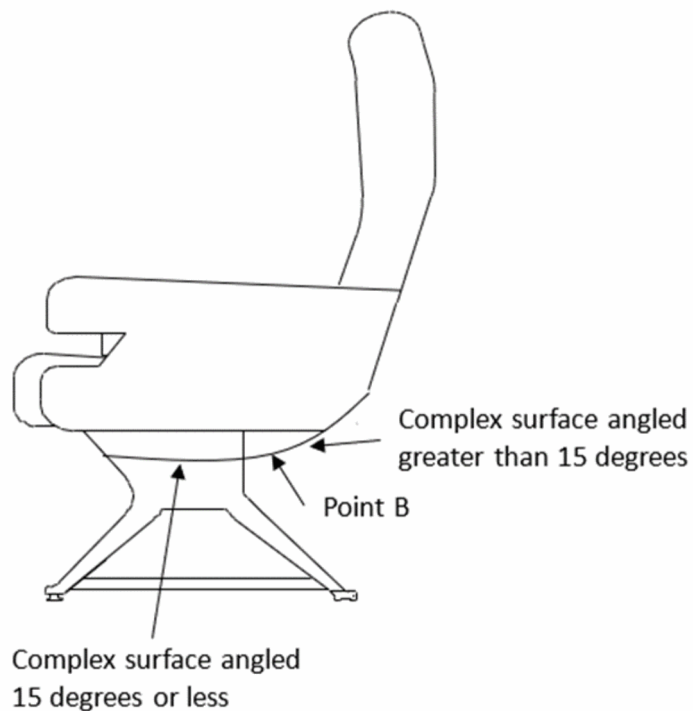

**Figure 11B - Acceptable complex shape for upper surface of underseat stowage volume**

### 3.8 Seat Safety Placards

#### 3.8.1 Applicable Policy and Regulations

#### 14 CFR Part 25.1411 Amendment 25-116

(b) Stowage provisions. Stowage provisions for required emergency equipment must be furnished and must:

- (1) Be arranged so that the equipment is directly accessible, and its location is obvious.

#### 14 CFR Part 25.1541

(a) The airplane must contain:

- (1) The specified markings and placards; and
- (2) Any additional information, instrument markings, and placards required for the safe operation if there are unusual design, operating, or handling characteristics.

(b) Each marking and placard prescribed in paragraph (a) of this section:

- (1) Must be displayed in a conspicuous place; and
- (2) May not be easily erased, disfigured, or obscured.

#### AC 25-17A CHG 1 Para 1041(b)(1)

Placards indicating emergency equipment should be approximately at eye level and should not blend in with the surrounding decor. A color contrast that complies with § 25.811(f)(2) is acceptable. If the emergency equipment is located in the upper or lower compartment, the eye level placard should have an arrow indicating the compartment. Each compartment containing emergency equipment such as life preservers, rafts, slides, slide/rafts, or fire extinguishers should be placarded as to its contents. For small executive airplanes which may not allow placards to be located at eye level, the placards should be located in as conspicuous a location as practicable.

### 3.8.2 Recommended Practice

Safety placards on occupant seats should be permanently affixed, located such that they cannot be easily obscured and of a type that cannot be easily erased. The lettering height and color contrast should be sufficient to allow the placard to be read by the intended occupant

Placards for life vest location should be sufficiently descriptive to direct the occupant to the life vest. Acceptable examples include LIFE VEST UNDER YOUR SEAT, LIFE VEST UNDER ARMREST (with an arrow pointing to the appropriate armrest), or LIFE VEST UNDER CENTER ARMREST.

## 3.9 Literature Pocket Stowage Capacity

### 3.9.1 Applicable Policy and Regulations

#### 14 CFR Part 25.601

General.

The airplane may not have design features or details that experience has shown to be hazardous or unreliable. The suitability of each questionable design detail and part must be established by tests.

### 3.9.2 Recommended Practice

#### Flexible Literature Pockets

Flexible literature pockets are open stowage areas on any location of the seat, or associated seat furniture, which provides unobstructed access to the passenger safety card and magazines.

#### Rigid Literature Pockets

Rigid literature pockets are open stowage areas on any location of the seat, or associated seat furniture, which provides unobstructed access to the passenger safety card and magazines. Rigid pockets are typically molded into the seat back shell.

#### Requirements for all Literature Pockets

A literature pocket is an open stowage area on any location of the seat, or associated seat furniture, which provides unobstructed access to the passenger safety card and magazines. Literature pockets may be either flexible or rigid (see “Definitions”). Literature pockets are not required, but when included the following standards shall be met:

Dimension	Maximum *
Width	18 inches (46 cm)
Height	15 inches (38 cm)
Depth	3 inches (7.6 cm)

- a. [Figure 12](#) defines the overall recommended size for literature pockets, irrespective of dividers or baffles. Although no minimum sizes are defined, it is recommended that the need for access and inspection be considered when pocket sizes are determined.

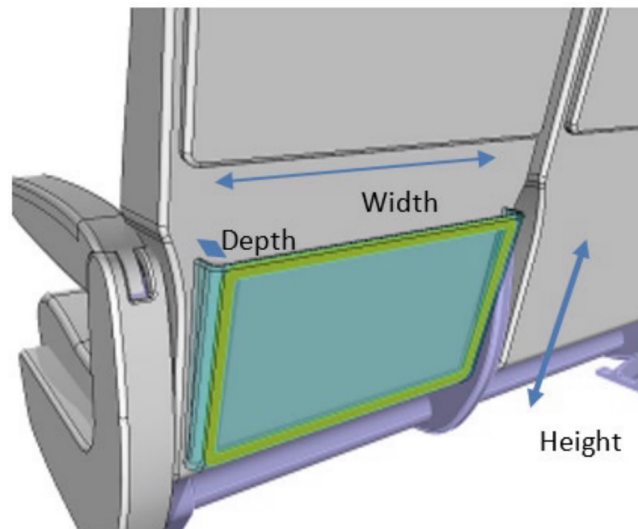

\* The literature pocket shall not have a volume greater than 231 in<sup>3</sup> (3785 cm<sup>3</sup>). [Note: this volume is intended to act as a limiting factor preventing the creation of an 18 x 15 x 3 inch (46 x 38 x 7.6 cm) pocket.]

For a flexible literature pocket, this volume is in the expanded condition.

**Figure 12 - Literature pocket size recommendations**

- b. Literature pockets shall be designed and substantiated as part of the seat system for a minimum content weight of 3 pounds (1.36 kg).
- c. Internal dividers may be used in literature pockets. External pockets added to literature pockets, such as those shown in [Figure 13](#), shall be sized to stow the safety briefing card or sick bag only. The volume of these external pockets does not need to be included in the volume limit defined in item a. above.



**Figure 13 - External pockets**

- d. Literature pockets with a flexible aperture opening shall have some means of spring back or retainer.
- e. Without application of any required inertia loads, literature pockets shall retain their contents throughout the full range of seat motion. Typically, this means fully upright to fully reclined, but if the seat possesses other motions, these must also be considered.
- f. Literature pockets located such that their contents can be ejected toward an occupant as a result of forward inertia, such as would typically occur on the forward side of an aft facing seat in a row-to-row layout, shall be sized to stow the safety briefing card or sick-bag only.
- g. Literature pockets on seats intended for use as public transport shall be designed and located to facilitate rapid inspection of the contents.
- h. Literature pockets do not require weight limit placards.
- i. Rigid literature pockets with an aperture opening higher than 25 inches (63.5 cm) above the floor shall be no more than 1 inch (2.5 cm) in depth, may be divided per item c. above, and may require additional cutouts to satisfy item g. above.
- j. When a second literature pocket per passenger is used, the size requirements defined in item a. above are applicable to each pocket. Each pocket shall be loaded as described in item b. above.
- k. One literature pocket per passenger position is permitted without a placard stating "Literature Only" when the literature pocket is installed below 25 inches from the floor. All other literature pockets shall be placarded "Literature Only" regardless of the location.

### 3.10 Seat Back Mounted Tray Table Latch Inadvertent Operation

#### 3.10.1 Applicable Policy and Regulations

#### 14 CFR Part 25.813 Amendment 25-128

- (a) There must be a passageway leading from the nearest main aisle to each Type A, Type B, Type C, Type I, or Type II emergency exit and between individual passenger areas. Each passageway leading to a Type A or Type B exit must be unobstructed and at least 36 inches (91.4 cm) wide. Passageways between individual passenger areas and those leading to Type I, Type II, or Type C emergency exits must be unobstructed and at least 20 inches (50.8 cm) wide. Unless there are two or more main aisles, each Type A or Type B exit must be located so that there is passenger flow along the main aisle to that exit from both the forward and aft directions. If two or more main aisles are provided, there must be unobstructed cross-aisles at least 20 inches (50.8 cm) wide between main aisles.
- (c) The following must be provided for each Type III or Type IV exit:

- (1) There must be access from the nearest aisle to each exit. In addition, for each Type III exit in an airplane that has a passenger seating configuration of 60 or more.
  - (i) Except as provided in paragraph (c)(1)(ii), the access must be provided by an unobstructed passageway that is at least 10 inches (25.4 cm) in width for interior arrangements in which the adjacent seat rows on the exit side of the aisle contain no more than two seats, or 20 inches (50.8 cm) in width for interior arrangements in which those rows contain three seats. The width of the passageway must be measured with adjacent seats adjusted to their most adverse position. The centerline of the required passageway width must not be displaced more than 5 inches (12.7 cm) horizontally from that of the exit.
  - (ii) In lieu of one 10-inch (25.4-cm) or 20-inch (50.8-cm) passageway, there may be two passageways, between seat rows only, that must be at least 6 inches (15.2 cm) in width and lead to an unobstructed space adjacent to each exit. (Adjacent exits must not share a common passageway.) The width of the passageways must be measured with adjacent seats adjusted to their most adverse position. The unobstructed space adjacent to the exit must extend vertically from the floor to the ceiling (or bottom of sidewall stowage bins), inboard from the exit for a distance not less than the width of the narrowest passenger seat installed on the airplane, and from the forward edge of the forward passageway to the aft edge of the aft passageway. The exit opening must be totally within the fore and aft bounds of the unobstructed space.
- (2) In addition to the access:
  - (i) For airplanes that have a passenger seating configuration of 20 or more, the projected opening of the exit provided must not be obstructed and there must be no interference in opening the exit by seats, berths, or other protrusions (including any seatback in the most adverse position) for a distance from that exit not less than the width of the narrowest passenger seat installed on the airplane.
  - (ii) For airplanes that have a passenger seating configuration of 19 or fewer, there may be minor obstructions in this region, if there are compensating factors to maintain the effectiveness of the exit.

### 3.10.2 Recommended Practice

To prevent inadvertently deployed tray tables from blocking escape paths or interfering with door motion, the seat back table latch should prevent the table from deploying following a moderate bump on the upper surface of the seat back, or by a person brushing past.

The following design features may aid in meeting that objective:

- \* The tray table latch is independently locked.

The latch has an independent locking feature that is out of the plane of motion. This locking feature must be independently released for the latch to be opened and must automatically lock the table latch when the tray table is stowed.

- \* The tray table latch motion is in a direction other than that of passenger egress.

The passengers will predominantly generate the inadvertent release force in the direction of travel. If the tray table latch must be moved in a direction perpendicular or opposite to that travel in order to release the table, inadvertent release will be less likely.

- \* The tray table latch is recessed below surrounding structure.

Maintain the latch below a plane of surrounding structure. If the latch cannot be contacted by a straight edge as it is slid over the tray latch area, then the latch is sufficiently recessed so that inadvertent release is unlikely.

### 3.11 Pinch Hazards

#### 3.11.1 Applicable Policy and Regulations

#### 14 CFR Part 25.601

General.

The airplane may not have design features or details that experience has shown to be hazardous or unreliable. The suitability of each questionable design detail and part must be established by tests.

### 3.11.2 Recommended Practice

Under normal operation and proper usage moving parts accessible to passengers and crew (e.g., Legrests, deployable video, integral tables, etc.) should be designed to minimize the potential for pinching and/or shearing hazards.

Designs that contain the potential for pinching and/or shearing should be evaluated for passenger (children and adults) accessibility defined in 3.11.2.1. If the suspect area(s) is accessible the injury potential analysis in 3.11.2.2 should be performed.

NOTE: A rate check device, in the context of this section (3.11), is a device that slows the movement of a feature to an extent that injury will not occur.

#### 3.11.2.1 Accessibility

Any opening greater than 0.25-inch (0.6-cm) diameter or equivalent opening if in a shape other than a circle that separates an occupant from a hazard is considered accessible.

#### 3.11.2.2 Injury Potential Analysis

[Table 2](#) should be used in conjunction with the actuation and multiplier categories to determine if testing or eliminating accessibility (through the use of a shroud for example) is appropriate.

**Table 2 - Injury potential analysis**

		Actuation Category			
		1	2	3	4
Multiplier Category	a	g	g	g	g
	b	g	g	y	y
	c	g	y	y	y
	d	y	y	y	r
	e	r	r	r	r

Legend:

**Green** - A shroud or test is not recommended.

**Yellow** - A shroud or a test may be needed.

**Red** - Recommended that a test be performed, or a shroud be used, as appropriate.

#### 3.11.2.3 Actuation Category Definition

The actuation category is a rating assigned to a design that ranges in scale from 1 to 4. The rating is a combination of effects that include the method by which an action can occur and the individual causing the action. The category scale, from 1 to 4, is defined below.

1 - Is defined as a manual action initiated by an individual onto themselves. It is the least risk because the action will stop as the pressure is applied. Sharp edges are assumed to be eliminated.

2 - Is defined as a manual action involving two persons. It is a higher risk because the person controlling the action does not necessarily know the action has the potential to cause injury.



3 - Is defined as a controlled powered (electrical) actuation (an action that can be terminated by releasing the controlled command) is an action that is still a higher risk because of the ease the operator can apply the pressure.

4a - Uncontrolled powered (electrical) actuation: The action, once initiated, may not be able to be interrupted to stop the actuation. This is an additional risk because of the potential for the action not to be stopped.

4b - Stored energy devices: This is a device that includes stored hydraulics, spring loaded, etc., where the stored energy is used to activate the motion that could cause the injury. This device, once initiated, may not be interrupted to stop the actuation.

#### 3.11.2.4 Multiplier Categories

The multiplier category is a subjective value that combines an edge sharpness with the maximum rate of movement of the pinching elements that will most likely be seen in service. The edge sharpness ranges from blunt to the sharpest edge that is not excluded by 3.12. The category ranges from a to e, where "a" is a blunt edge and permits a reasonable person to easily remove their body part from the pinch area, and "e" is a relative sharp edge that operates at a rate that a reasonable person will not have sufficient time to remove their body part.

3.11.2.5 Examples of potential pinch hazards are shown in Figures [14](#), [15](#), [16](#), [17](#), [18](#), and [19](#).

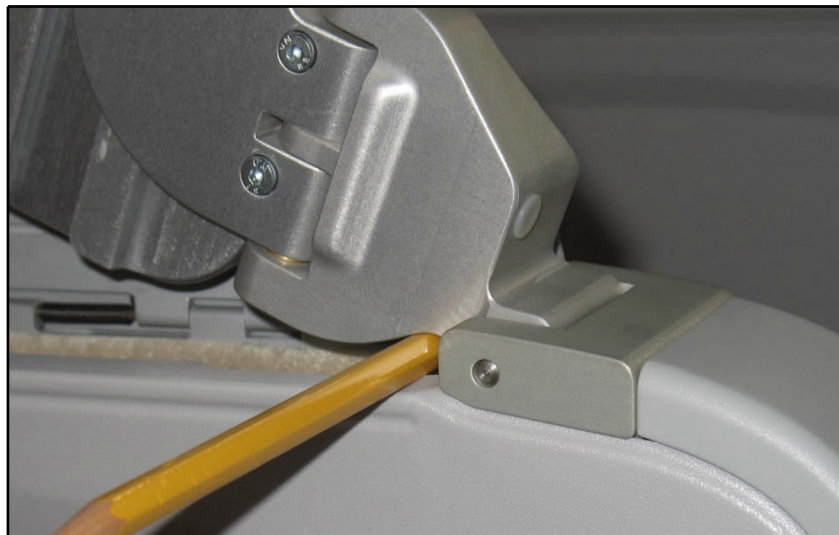

**Figure 14 - This is the hinge for an in-arm video display.  
It is an example of a type 1a score from the injury potential analysis table.**





**Figure 15 - This is the arm cap for an in-arm tray table seat.  
It is an example of a type 1a score from the injury potential analysis table.**



**Figure 16 - This is a hinge for an in-arm tray table.  
It is an example of a type 1a score from the injury potential analysis table.**



**Figure 17 - This is a spring-mounted stowage box door.  
It is an example of a type 4a score from the injury potential analysis table based on spring force potential.**



**Figure 18 - This is an aft mounted food tray table.  
It is an example of a type 1a score from the injury potential analysis table.**

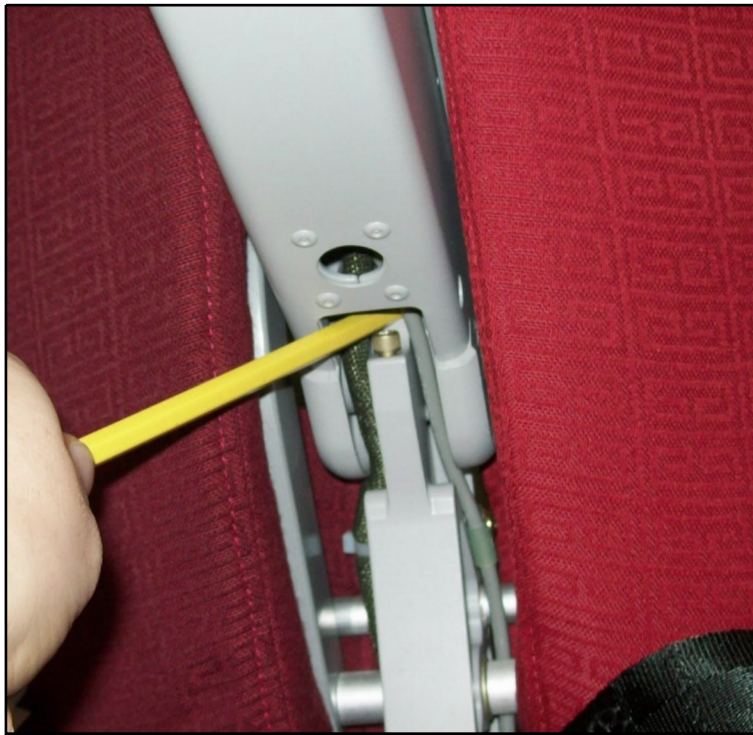

**Figure 19 - This is the hinge point for a rotating armrest.  
It is an example of a type 2b score from the injury potential analysis table.**

Additional examples of scores from the injury potential analysis table are:

- \* An attendant seat automatic seat pan closure with a rate check device would receive a 4a score. A seat pan closure without a rate check device would be receiving a more severe score.
- \* A rotating armrest that can crush but not shear would receive a 2b score.
- \* A rotating armrest with a shearing action would receive a 2e score.
- \* A seat where two sliding plates with interposing lightening holes with powered actuators would receive a 4e score.
- \* A scissor action on an electrically operated legrest that operates fairly slowly with reasonably blunt edges would receive a 3c score. A faster motion with sharper edges would receive a 3e score.

### 3.11.2.6 Test

Test all suspect areas of the mechanism. To test the severity of a mechanism that could cause injury, use a standard #2 (HB) wood pencil (alternatively, a 0.3-inch (8-mm)  $\pm$  0.04-inch (1-mm) diameter dowel made from California incense cedar or equivalent softwood is also acceptable) of approximately 6 inches (152 cm) to simulate a finger or toe. Place the pencil into the suspect portion of the mechanism (e.g., typically any acute angle that closes in a scissor or shear action mechanism, or a cavity that closes during a rotation). For a suspect cavity, insert the pencil at minimum 1 inch (2.5 cm), or as far as space permits for access to the shear plane not exceeding the length defined above. Hold, or fasten a holder to the pencil, and firmly and deliberately operate the deployment mechanism such that the suspect area closes on the pencil or acceptable alternate.

### 3.11.2.7 Pass/Fail Criteria

Make certain the pencil remained in position during the test(s). If the pencil or acceptable alternate is significantly marked/crushed (e.g., less than one half the original thickness remaining post-test) from any of the tests, the mechanism is unacceptable without modification to prevent access or altering the design to improve performance.

### 3.12 Sharp Edges

#### 3.12.1 Applicable Policy and Regulations

##### 14 CFR Part 25.601

###### General.

The airplane may not have design features or details that experience has shown to be hazardous or unreliable. The suitability of each questionable design detail and part must be established by tests.

#### 3.12.2 Recommended Practice

Edges that could cut skin during normal use (including in edges on electrical equipment) should be eliminated and for maintenance should be minimized. A suspected sharp edge should be checked by utilizing a tool that meets the requirements of UL 1439. To be considered non-injurious, edges that are accessible (as defined in 3.11.2.1) and could cut skin during normal use shall meet either of the standards listed below:

- a. NASA Standard 3000 Volume I (NASA-STD-3000 Vol I), Man-Systems Integration Standards, Revision B, July 1995, Section 6.3.3; or
- b. UL 1439, Standard for Tests for Sharpness of Edges on Equipment, Edition 4, February 26, 1998, with revisions through 6/1/2004.

In addition, the seat should not have any feature whose edges or corners are exposed when deployed, that presents a potential to impede an occupant's egress (e.g., cocktail table, seat back and in-arm video, flip-out PCU, ashtray, etc.).

### 3.13 Evaluation of Surfaces within Head Strike Zone

#### 3.13.1 Applicable Policy and Regulations

##### 14 CFR Part 25.785 Amendment 25-88

- (b) Each seat, berth, safety belt, harness, and adjacent part of the airplane at each station designated as occupiable during takeoff and landing must be designed so that a person making proper use of these facilities will not suffer serious injury in an emergency landing as a result of the inertia forces specified in Sections 25.561 and 25.562.
- (d) Each occupant of a seat that makes more than an 18-degree angle with the vertical plane containing the airplane centerline must be protected from head injury by a safety belt and an energy absorbing rest that will support the arms, shoulders, head, and spine, or by a safety belt and shoulder harness that will prevent the head from contacting any injurious object. Each occupant of any other seat must be protected from the head injury by a safety belt and, as appropriate to the type, location, and angle of facing of each seat, by one or more of the following:
  - (1) The elimination of any injurious object within striking radius of the head.
  - (2) AC 25.562-1B, Change 1
  - (3) AC 25-17A CHG 1, Change 1
  - (4) FAA Policy Memorandum ANM-03-115-31, "Conducting Component Level Tests to Demonstrate Compliance with §§ 25.785(b) and (d)"

#### 3.13.2 Recommended Practice

This recommended practice addresses the elimination of injurious objects within the striking radius of the head (25.785(d)(2)) for occupants seated in a forward or oblique facing seat and restrained primarily using a lap belt only. Ancillary occupant restraint from structure does not invalidate the application of this section.



Methods in this section can be used to demonstrate that surfaces located in proximity of the seated occupant are not injurious and do not impede egress after being impacted. The two injury mechanisms to be evaluated are blunt trauma to the head and injuries due to post-impact sharp edges and protrusions. The head strike zone to be evaluated is dependent on whether the seat installation is to be HIC compliant.

### 3.13.2.1 HIC Compliant Seat Installations

**Question:** Is the surface being evaluated shown to be HIC compliant by head non-contact?

**Yes:** Injury and egress concerns due to head impact are satisfied.

**No:** Additional substantiation required.

- a. Blunt trauma to the head: Acceptable injury mitigation is done by demonstrating  $HIC \leq 1000$ .
- b. Sharp edges, protrusions, and egress impediments: Surfaces within the head strike zones defined below are to be evaluated per 3.13.2.3.
  1. Surfaces directly in front of the seated occupant in a row-to-row configuration. The headstrike zone is defined by the following method (see [Figure 20A](#)):
    - \* Zone height upper limit: Location of 95% male head contact.
    - \* Zone height lower limit: 18 inches (45.7 cm) from floor.
    - \* Zone width: The width of the seat back/seat shell up to 10 inches (25.4 cm) laterally from the midpoint between seat belt anchors.

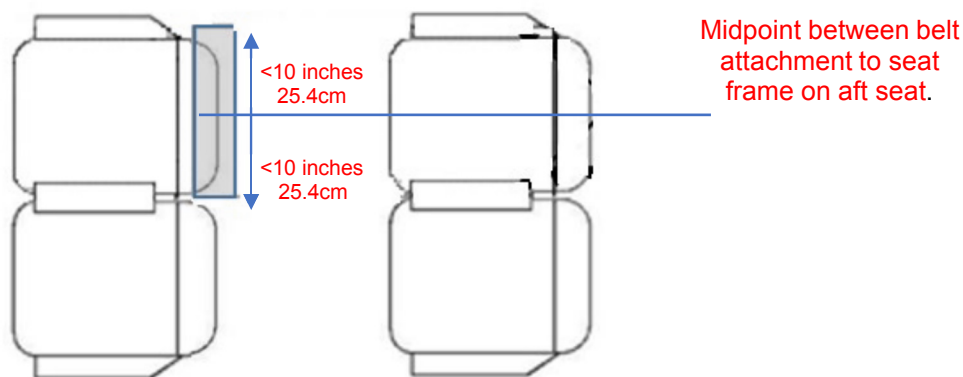

**Figure 20A - Seat back sharp edges head strike zone width (HIC compliant)**

**NOTE:** Rotating and translating armrests that extend aft of the seat back shall be considered as part of the seat back width assessment.

The zone height upper limit for the 95% male is defined using a 3-inch (7.6-cm) offset from the 50% male ATD head path (top of head). If the head path is not measured (as in a row-to-row HIC test), the zone height upper limit is defined from the highest point of 50% male ATD head contact on the seatback plus 3 inches (7.6 cm) in the vertical direction (upwards) (see [Figure 20B](#)). Head contact point to be determined using the process defined in AC25.562-1B Change 1. If the dynamic test has been modified to account for the 95% male head path (usually by moving the seats closer together), the 3-inch (7.6-cm) offset from the 50% male ATD head path is unnecessary.

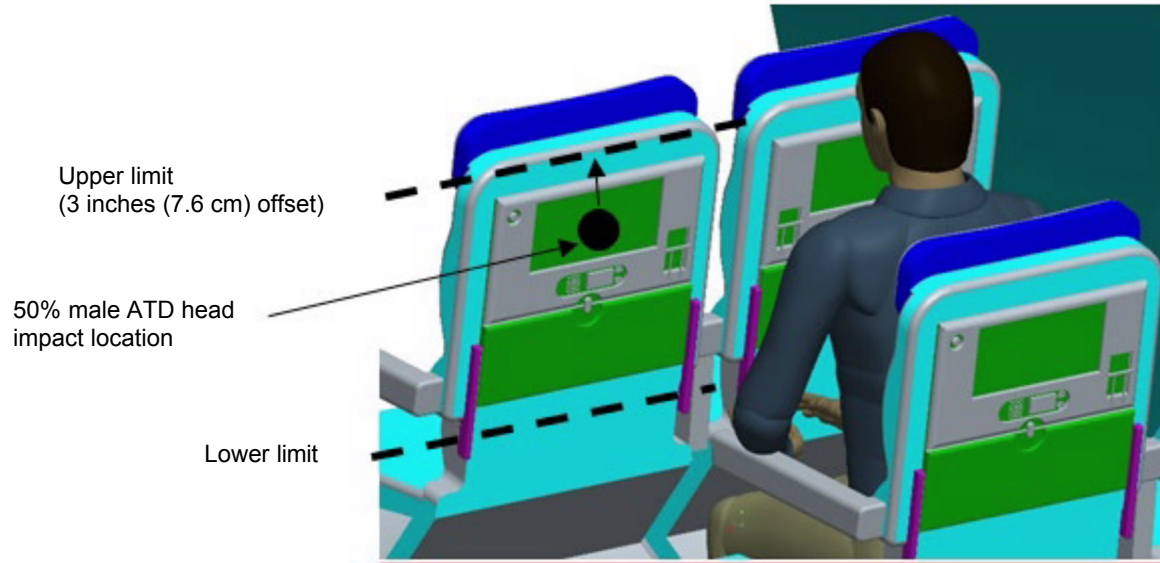

**Figure 20B - Seat back sharp edges head strike zone upper and lower height (HIC compliant)**

2. Other surfaces: The headstrike zone is the same as the one to demonstrate head non-contact.

### 3.13.2.2 Seat Installations Not HIC Compliant

For seat installations not required to evaluate the HIC under the dynamic loading conditions defined in 5.3 of AS8049, the head strike zone defined in Figure 21 should be used to determine whether an interior surface requires further evaluation.

NOTE: The 20.5-inch (52.1-cm) arc radius is based on the distance between the shoulder height and estimated upper torso pivot height of a lap belt only restrained 5% female.

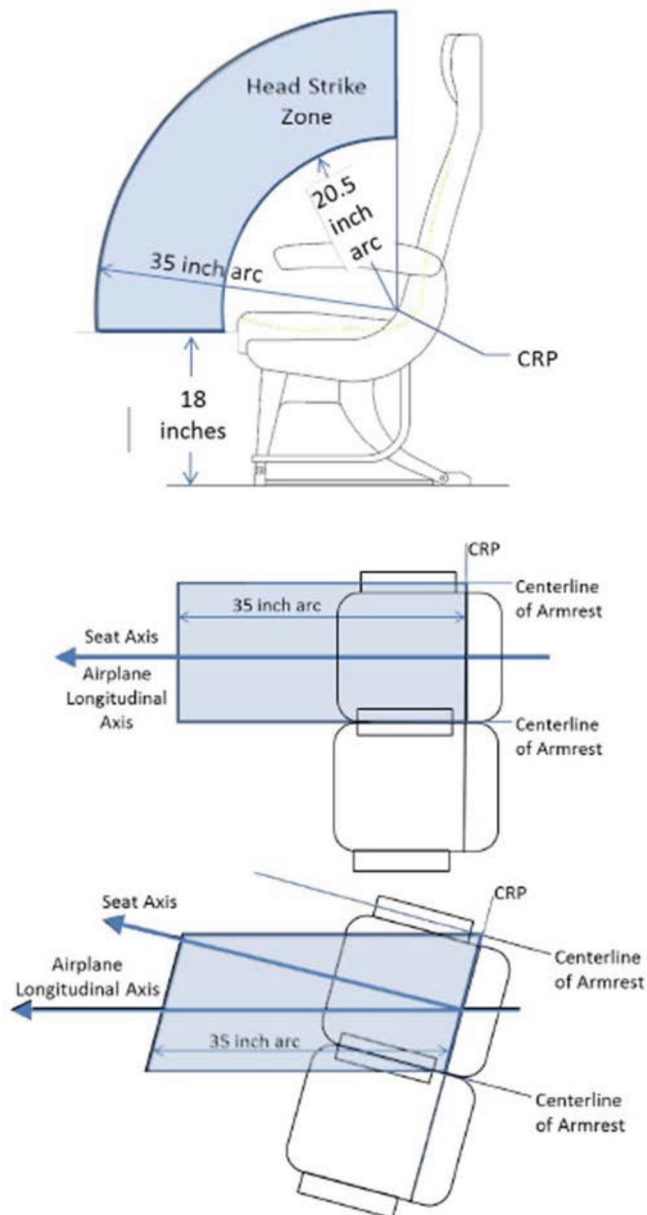

**Figure 21 - Head strike zone definition (non-HIC compliant)**

**Question:** Is the surface being evaluated outside the headstrike zone defined in Figure 21?

**Yes:** Injury and egress concerns due to head impact are satisfied.

**No:** Additional substantiation required.

- a. Blunt trauma injuries to the head: Potentially injurious objects within the Figure 21 head strike zone may be evaluated by the following test or analysis methods for blunt trauma.
1. Component test methods and acceptance criteria defined in FAA Policy Memorandum ANM-03-115-31.
  2. Demonstrating that head contact with the surface results in a HIC  $\leq 1000$ . HIC data to be gathered per AS8049. Data from a similar seat may be used in this demonstration.
  3. Analysis showing that the occupant head will not contact the surface in question. Analysis should address 5% female, 50% male, and 95% male occupant sizes. Load vector yaw angle used in the analysis is  $\pm 10$  degrees from airplane longitudinal axis.

4. Seat back only: The weight of seat back accessories is less than 3 pounds (1.3 kg), and the seat back is considered “standard” per FAA Policy Memorandum ANM-03-115-31. Seat back accessories are electrical components attached to the seat back structure during taxi, takeoff, and landing, such as video monitors, handsets, headphone outlets, PC power outlets, USB, or other data ports.
- b. Sharp edges, protrusions, and egress impediments: Surfaces within the head strike zone defined in Figure 21 are to be evaluated per 3.13.2.3.

### 3.13.2.3 Evaluating Potential Sharp Edges, Protrusions, and Egress Impediments

Surfaces within the applicable head strike zones (either HIC or non-HIC compliant seat installations) should be evaluated for the potential to generate unacceptable sharp edges, protrusions, and egress impediments due to head impact. The following methods may be used.

- a. Impact the surface with the following methods and evaluate the surface post-test condition.
  1. ATD head impact during seat dynamic testing.
  2. Component test methods defined in FAA Policy Memorandum ANM-03-115-31. The head acceleration pass/fail criterion is not applicable.
- b. Head non-contact under the dynamic loading conditions of 5.3 in AS8049. This will only address a 50% male occupant size. Additional spatial analysis for the other occupant sizes applicable to the head strike zone being evaluated is needed.
- c. Rational analysis based on material properties, construction, and previous test data. For example, a metal surface will likely not be frangible. Surfaces covered by a foam layer (like an armrest) would also not be expected to generate sharp edges. A seat back surface may have demonstrated acceptable impact resistance from an ATD head impact somewhere else on the seat back.
- d. For surfaces not directly in front of the seated occupant in a row-to-row configuration: Spatial analysis showing that the occupant head will not contact the surface in question. Analysis should address 5th percentile female, 50th percentile male, and 95th percentile male occupant sizes. Load vector yaw angle used in the analysis is  $\pm 10$  degrees from airplane longitudinal axis.

## 3.14 Seat Features Adjusted with/without Tools

### 3.14.1 Applicable Policy and Regulations

#### 14 CFR Part 25.561 Amendment 25-91

- (d) Seats and items of mass (and their supporting structure) must not deform under any loads up to those specified in paragraph (b)(3) of this section in any manner that would impede subsequent rapid evacuation of occupants.

#### 14 CFR Part 25.789 Amendment 25-46

- (a) Means must be provided to prevent each item of mass (that is part of the airplane type design) in a passenger or crew compartment or galley from becoming a hazard by shifting under the appropriate maximum load factors corresponding to the specified flight and ground load conditions, and to the emergency landing conditions of Sec. 25.561(b).

#### 14 CFR Part 25.813 Amendment 25-128

- (a) There must be a passageway leading from the nearest main aisle to each Type A, Type B, Type C, Type I, or Type II emergency exit and between individual passenger areas. Each passageway leading to a Type A or Type B exit must be unobstructed and at least 36 inches (91.4 cm) wide. Passageways between individual passenger areas and those leading to Type I, Type II, or Type C emergency exits must be unobstructed and at least 20 inches (50.8 cm) wide. Unless there are two or more main aisles, each Type A or Type B exit must be located so that there is passenger flow along the main aisle to that exit from both the forward and aft directions. If two or more main aisles are provided, there must be unobstructed cross-aisles at least 20 inches (50.8 cm) wide between main aisles.



(c) The following must be provided for each Type III or Type IV exit:

- (1) There must be access from the nearest aisle to each exit. In addition, for each Type III exit in an airplane that has a passenger seating configuration of 60 or more
  - (i) Except as provided in paragraph (c)(1)(ii), the access must be provided by an unobstructed passageway that is at least 10 inches (25.4 cm) in width for interior arrangements in which the adjacent seat rows on the exit side of the aisle contain no more than two seats, or 20 inches (50.8 cm) in width for interior arrangements in which those rows contain three seats. The width of the passageway must be measured with adjacent seats adjusted to their most adverse position. The centerline of the required passageway width must not be displaced more than 5 inches (12.7 cm) horizontally from that of the exit.
  - (ii) In lieu of one 10-inch or 20-inch (25.4-cm or 50.8-cm) passageway, there may be two passageways, between seat rows only, that must be at least 6 inches (15.2 cm) in width and lead to an unobstructed space adjacent to each exit. (Adjacent exits must not share a common passageway.) The width of the passageways must be measured with adjacent seats adjusted to their most adverse position. The unobstructed space adjacent to the exit must extend vertically from the floor to the ceiling (or bottom of sidewall stowage bins), inboard from the exit for a distance not less than the width of the narrowest passenger seat installed on the airplane, and from the forward edge of the forward passageway to the aft edge of the aft passageway. The exit opening must be totally within the fore and aft bounds of the unobstructed space.
- (2) In addition to the access:
  - (i) For airplanes that have a passenger seating configuration of 20 or more, the projected opening of the exit provided must not be obstructed and there must be no interference in opening the exit by seats, berths, or other protrusions (including any seatback in the most adverse position) for a distance from that exit not less than the width of the narrowest passenger seat installed on the airplane.
  - (ii) For airplanes that have a passenger seating configuration of 19 or fewer, there may be minor obstructions in this region, if there are compensating factors to maintain the effectiveness of the exit.

### 3.14.2 Recommended Practice

Limit stops on seat settings, such as seat back upright position, maximum recline position, etc., should be designed so that they are adjustable only with the use of tools. If such an adjustment can be made without the use of tools, the location must be inaccessible and not visible to the occupant or designed so that incorrect adjustment is conspicuous to the flight crew. (For example if the adjustable element were under the bottom cushion and the seat pan/fabric, or if improper adjustment would obviously disconnect the seat back or center console from the seat assembly.)

### 3.15 Legrest and Footbar Retention

#### 3.15.1 Applicable Policy and Regulations

##### 14 CFR Part 25.789 Amendment 25-46

- (a) Means must be provided to prevent each item of mass (that is part of the airplane type design) in a passenger or crew compartment or galley from becoming a hazard by shifting under the appropriate maximum load factors corresponding to the specified flight and ground load conditions, and to the emergency landing conditions of Sec. 25.561(b).

##### 14 CFR Part 25.813 Amendment 25-128

- (a) There must be a passageway leading from the nearest main aisle to each Type A, Type B, Type C, Type I, or Type II emergency exit and between individual passenger areas. Each passageway leading to a Type A or Type B exit must be unobstructed and at least 36-inches (91.4-cm) wide. Passageways between individual passenger areas and those leading to Type I, Type II, or Type C emergency exits must be unobstructed and at least 20-inches (50.8-cm) wide. Unless there are two or more main aisles, each Type A or Type B exit must be located so that there is passenger flow along the main aisle to that exit from both the forward and aft directions. If two or more main aisles are provided, there must be unobstructed cross-aisles at least 20-inches (50.8-cm) wide between main aisles.

(c) The following must be provided for each Type III or Type IV exit:

- (1) There must be access from the nearest aisle to each exit. In addition, for each Type III exit in an airplane that has a passenger seating configuration of 60 or more.
  - (i) Except as provided in paragraph (c)(1)(ii), the access must be provided by an unobstructed passageway that is at least 10 inches (25.4 cm) in width for interior arrangements in which the adjacent seat rows on the exit side of the aisle contain no more than two seats, or 20 inches (50.8 cm) in width for interior arrangements in which those rows contain three seats. The width of the passageway must be measured with adjacent seats adjusted to their most adverse position. The centerline of the required passageway width must not be displaced more than 5 inches (12.7 cm) horizontally from that of the exit.
  - (ii) In lieu of one 10-inch or 20-inch (25.4-cm or 50.8-cm) passageway, there may be two passageways, between seat rows only, that must be at least 6 inches (15.2 cm) in width and lead to an unobstructed space adjacent to each exit. (Adjacent exits must not share a common passageway.) The width of the passageways must be measured with adjacent seats adjusted to their most adverse position. The unobstructed space adjacent to the exit must extend vertically from the floor to the ceiling (or bottom of sidewall stowage bins), inboard from the exit for a distance not less than the width of the narrowest passenger seat installed on the airplane, and from the forward edge of the forward passageway to the aft edge of the aft passageway. The exit opening must be totally within the fore and aft bounds of the unobstructed space.
- (2) In addition to the access:
  - (i) For airplanes that have a passenger seating configuration of 20 or more, the projected opening of the exit provided must not be obstructed and there must be no interference in opening the exit by seats, berths, or other protrusions (including any seatback in the most adverse position) for a distance from that exit not less than the width of the narrowest passenger seat installed on the airplane.
  - (ii) For airplanes that have a passenger seating configuration of 19 or fewer, there may be minor obstructions in this region, if there are compensating factors to maintain the effectiveness of the exit.

### 3.15.2 Recommended Practice

Legrests and footrests/footbars in the stowed position (refer to Figure 31) shall be positively restrained so that they do not deploy or become a tripping hazard when subjected to the normal flight and emergency landing loads. This does not apply to aft mounted footrests/footbars.

### 3.16 Emergency Escape Path Marking

#### 3.16.1 Applicable Policy and Regulations

##### 14 CFR Part 25.811 Amendment 25-88

(c) Means must be provided to assist the occupants in locating the exits in conditions of dense smoke.

##### 14 CFR Part 25.812 Amendment 25-128

(e) Floor proximity emergency escape path marking must provide emergency evacuation guidance for passengers when all sources of illumination more than 4 feet (121.9 cm) above the cabin aisle floor are totally obscured.

#### 3.16.2 Recommended Practice

If a seat mounted emergency escape path marking system is installed, the light design and locations shall support the intent to indicate the escape path to exits.

The light assembly should be protected from damage by galley carts, luggage and normal occupant traffic. Because the escape path lighting is required for emergency situations, extra care should be taken to protect the wire routing and connector location from luggage and normal occupant activities.

### 3.17 Rotating and Translating Armrests

#### 3.17.1 Applicable Policy and Regulations

##### 14 CFR Part 25.785 Amendment 25-88

(d) Each occupant of a seat that makes more than an 18-degree angle with the vertical plane containing the airplane centerline must be protected from head injury by a safety belt and an energy absorbing rest that will support the arms, shoulders, head, and spine, or by a safety belt and shoulder harness that will prevent the head from contacting any injurious object. Each occupant of any other seat must be protected from the head injury by a safety belt and, as appropriate to the type, location, and angle of facing of each seat, by one or more of the following:

- (1) A shoulder harness that will prevent the head from contacting any injurious object.
- (2) The elimination of any injurious object within striking radius of the head.

##### AC 25-1 CHG 1 (14 CFR Part 25.785) guidance (5) Para (c)(2)

(5) Paragraph (c)(2). Some passenger seats are designed with armrests that pivot upward such that the armrest could protrude beyond the seatbacks resulting in a potentially hazardous condition to persons seated behind these seats. Armrests that are adequately de-lethalized or restricted such that they cannot protrude aft of either seatback in any position are acceptable.

#### 3.17.2 Recommended Practice

The armrest should not protrude beyond the aft most surface of the aft most adjacent seat back regardless of seat back position. The armrest may protrude aft when the seat is converted to accommodate a stretcher.

If an armrest protrudes beyond the seat back it should not present an injurious condition (see 3.13) considering the occupant sizes defined in 3.20 and the range of approved seat pitches.

Recommended methods to avoid injurious conditions when an armrest is rotated out of the normal operating position are:

- a. The armrest should rotate out of the head strike zone when:
  - \* A maximum force of 25 pounds (111 N) is applied at the most critical armrest location in the direction of likely head travel,
  - \* The armrest is at its most critical head strike position, and
  - \* The armrest is located within the head strike zone (see 3.13).
- b. The armrest is enveloped by one or more seat back profile.
- c. The armrest is located outside the head strike zone (see 3.13).
- d. The armrest cannot be contacted because the spacing between adjacent seat backs is such that a head (see 2.3) cannot fit between the two seat backs when in the take-off and landing position.
- e. The exposed portion of the armrest within the head strike zone is covered by material that is not injurious as recommended in 3.13.

NOTE: These requirements may be reinforced by cabin operational procedures.

-----

### 3.18 Electrically Actuated Features

#### 3.18.1 Applicable Policy and Regulations

All electrically actuated seat parts (legrests, footrests/footbars, seat arms, seat backs, and other electrically actuated accommodations) exposed to or interfacing with the passengers.

This section is applicable to occupants and operators of passenger seating only when occupants and operators are making proper use of the seats. This includes a precise working of the actuator system software. This testing should be performed using the software being delivered. This ARP is not applicable to crew seating or flight crew seating.

The words "passenger," "operator," and "cabin crew" are used throughout this section and are synonymous.

#### 14 CFR Part 25.601

General.

The airplane may not have design features or details that experience has shown to be hazardous or unreliable. The suitability of each questionable design detail and part must be established by tests.

#### 14 CFR Part 25.1301 Amdt 25-123

Function and installation.

(a) Each item of installed equipment must:

- (1) Be of a kind and design appropriate to its intended function;
- (2) Be labeled as to its identification, function, or operating limitations, or any applicable combination of these factors;
- (3) Be installed according to limitations specified for that equipment; and
- (4) Function properly when installed.

#### 3.18.2 Recommended Practice

##### 3.18.2.1 Background

There is a wide variability between seat designs, seat actuation systems, airplane interior configurations, and passenger body types. Seats are designed to easily accommodate all size passengers into various comfortable and required seating positions. However, the seat actuation systems which allow these easy and smooth seat movements must ensure passenger safety, while also allowing the necessary force required to move into and out of seating and lounging positions quickly and safely.

All seat/furniture electrically actuated moving parts which could potentially entrap and cause injury to passengers should be evaluated against this practice to ensure that any potentially hazardous mechanisms utilize body part safe forces.

Seats using electrically actuated moving parts should be designed to minimize the risk of passengers (adults and children) being exposed to compressive force hazards. This may be done by limiting access, limiting compressive forces that can be applied, or providing other features that reduce the risk of injury.

Designs that feature electrically actuated moving parts should be evaluated according to the criteria in the Hazard Determination in 3.18.2.4 to determine if there is a potential compression hazard. If there is, the Mitigating Factors Analysis Procedure in Section D should be performed.

Mechanical override features shall be evaluated per 3.11.

##### 3.18.2.2 Recommended Practices

One touch function is a passenger control unit button which when depressed once, commands the seat to continuously move into or out of specific seating or bed positions until the programmed position limit is reached.

- \* In order for the passenger to stop the seat movement (once started), they depress any passenger controller button.
- \* Some examples of common one touch function buttons are: TTL (taxi, takeoff, landing), various bed, sleeping, and recline positions.

Press and hold function is a passenger control unit function button which, when continuously held depressed, commands the seat to move into or out of specific seating or bed positions until the programmed position limit is reached or the passenger releases the depressed button.

- \* In order for the passenger to stop the seat movement, they simply lift their finger from the function button.
- \* Some examples of common press and hold function buttons are: Legrest extend/retract, seat back recline, TTL (taxi, takeoff, landing), various bed, sleeping, and recline positions.

Combination one touch/press and hold is a passenger control unit function button which when depressed once commands the seat to continuously move into specific seating or bed positions until a potentially hazardous area is approached and then stops. Then the passenger has to press and hold the button to reach the final position.

NOTE: PCU (passenger control unit) function buttons which do not cause seat position movement (i.e., reading light, attendant call, massage, etc.) are not to be considered as part of this section because they do not initiate seat movement.

Entrapment is a potential compression hazard that exists to a cabin occupant if an electrically actuated part approaches another part capable of opposing the motion with a resulting accessible gap of 5 inches (12.7 cm) or less.

Pressure points are exposed corners or edges (including structure if exposed), bolts, or hardware protruding in an accessible area.

### 3.18.2.3 Introduction

This section of the ARP defines a recommended method for testing electrically actuated features associated with occupant seating area and stationary surrounding objects. Seat/furniture and their installations are to be evaluated for potential passenger injury. Examples of mitigating features to reduce the risk of occupant injuries are provided.

The evaluation of the seat should take into account the interior configuration and identify both the hazards that may be present in the installed seat and the mitigating features that reduce the severity of the hazards.

A mitigating feature is something present within the seat design, seat operation, aircraft installation which reduces the probability of injury to passengers or cabin crew.

### 3.18.2.4 Hazard Determination

Use the flow chart and guidance material to determine if hazards exist in electrically actuated seat features. Moving seat parts accessible to the occupants (e.g., legrests, footrests/footbars deployable video, integral tables, etc.) should have restricted motion or be shielded so that pinching and passenger entrapment hazards are minimized. In this context, hazards are limited to physical injury to occupants or cabin crew due to electrically actuated features of seating areas. Use the flow chart and instructions that follow.

## **Section A - Can a body part become entrapped between a moving seat/furniture part and any object capable of opposing the motion?**

A potential compression hazard exists if an electrically actuated part approaches another part capable of opposing the motion with a resulting accessible gap of 5 inches (12.7 cm) or less. [1] [2]

NOTE: If the minimum resulting distance between the electrically actuated parts and the opposing parts is 5 inches (12.7 cm) or greater, it can be assumed that there is no hazard. This should be evaluated for opposing parts on or off the seat/furniture, in all adjustable positions of the parts.

#### Entrapment Evaluation

- \* The 5-inch (12.7-cm) criterion must be determined using electrically driven components only. Manually adjustable features (i.e., tray tables, video arms, footrests) may act as obstructions and should be considered as stationary object (opposing part).
- \* All gaps must be evaluated for the closest spacing.
- \* For each potential entrapment area, establish which body part is likely to be involved (arm, leg, hand, foot, neck, etc.) in normal seat usage.

#### **Section B - Are there bolts, hardware, structures on areas where the forces can be applied which create high pressure points?**

##### Identify High Pressure Points

- \* Are there exposed objects, edges, bolts, hardware, structure, etc.?
- \* Both the moving and stationary surfaces must be evaluated.

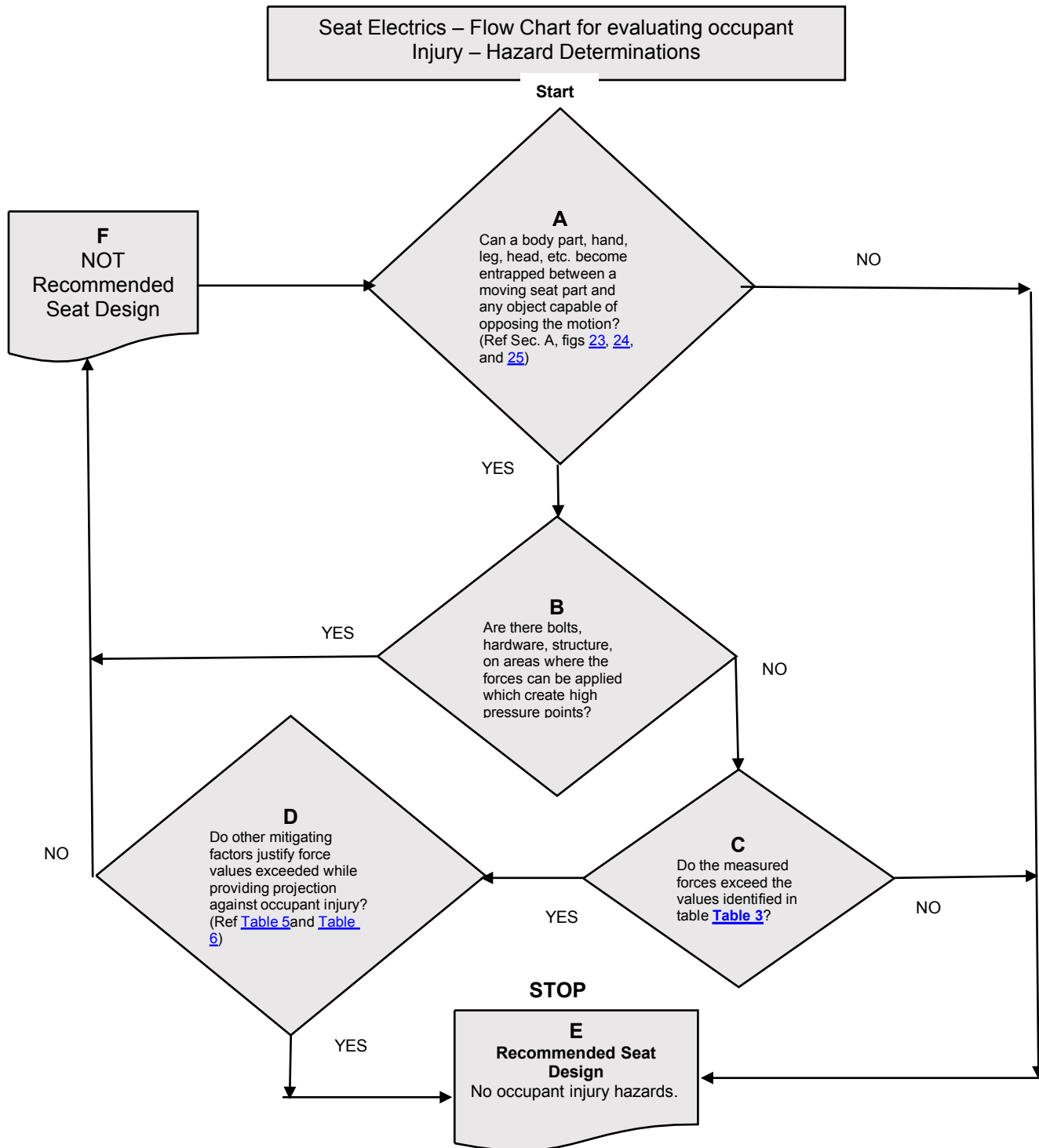

Figure 22 - Hazard determination chart

Section C - Do the measured forces exceed the values in [Table 3](#)? Yes or No

Body Part Force Levels (Max) (Adult data except where noted)**Table 3 - Maximum force values**

<b>Arm/Leg</b> [3]	<b>60 lbf</b>	<b>267 N</b>
<b>Skull (child)</b> [1] [2] [3]	<b>35 lbf</b>	<b>156 N</b>
<b>Hand/Foot</b> [4] [5] [6]	<b>35 lbf</b>	<b>156 N</b>
<b>Neck (child-adult)</b> [3] [7] [8]	<b>22.5-35 lbf</b>	<b>100-156 N</b>

NOTE: References to research data which are the basis for these values can be found in 3.18.3. Neck force value limits estimated, based on similarly vulnerable body areas, as well as the desire to include the neck as a risk area for both bone crushing, as well as for asphyxiation (due to wind pipe blockage/compression).

Maximum Body Part Force Limits

The seat designs should not have hazardous areas which expose passenger and cabin crew body parts to excessive force levels which exceed the maximums shown in [Table 3](#). Those positions where potential compression hazards are identified should be tested. See Figures [23](#), [24](#), and [25](#) for recommended starting measurement points. Add measurement points as appropriate for each specific potential hazard.

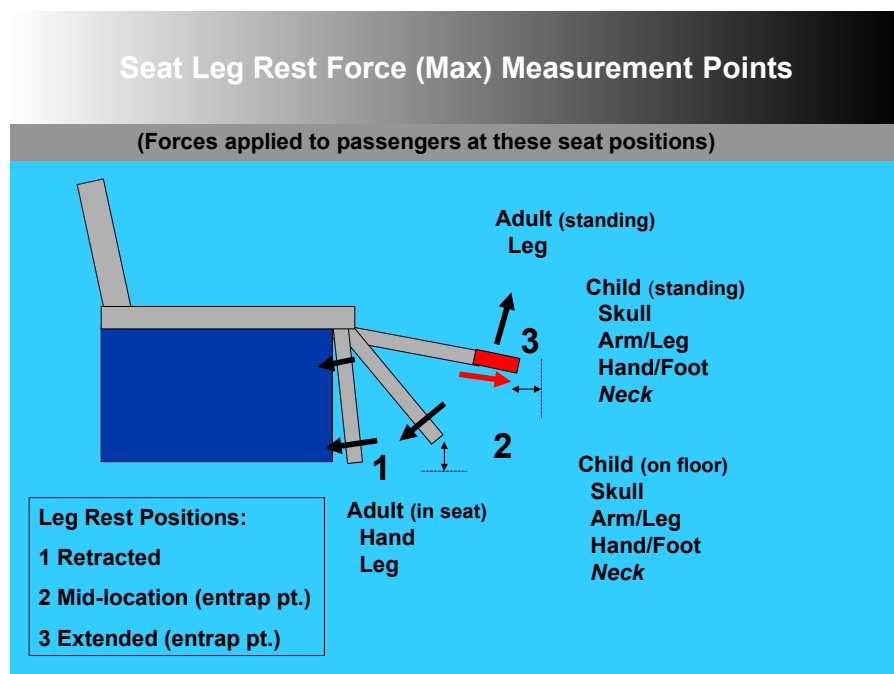
**Figure 23 - Legrest measurement points for moving parts**



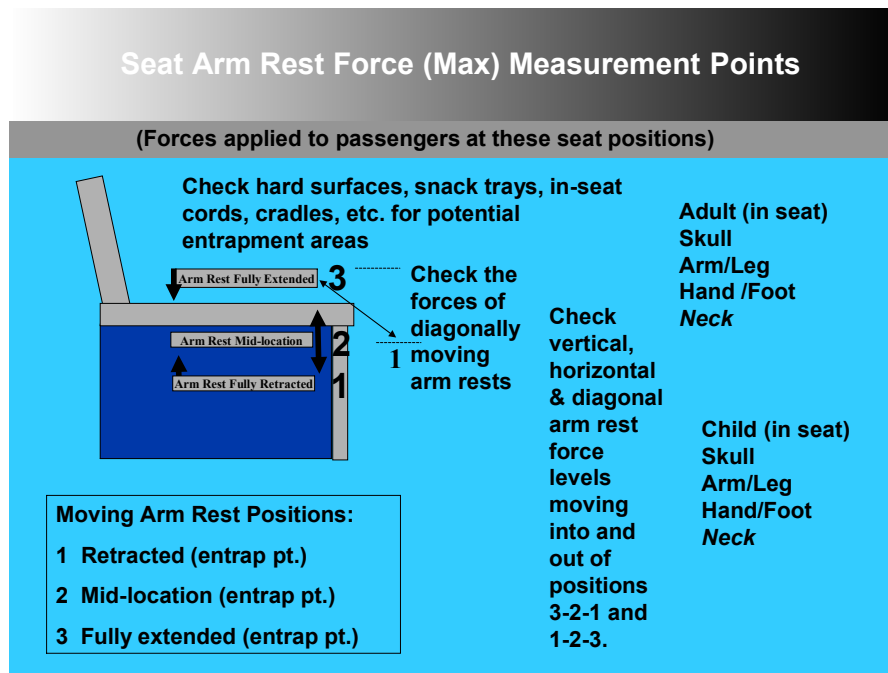

**Figure 24 - Armrest measurement points for moving parts**

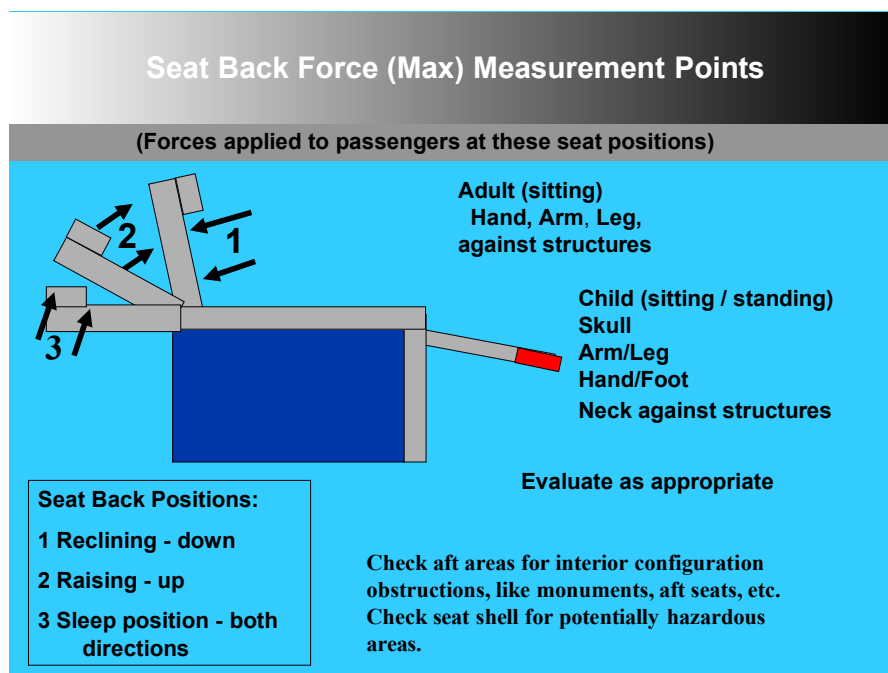
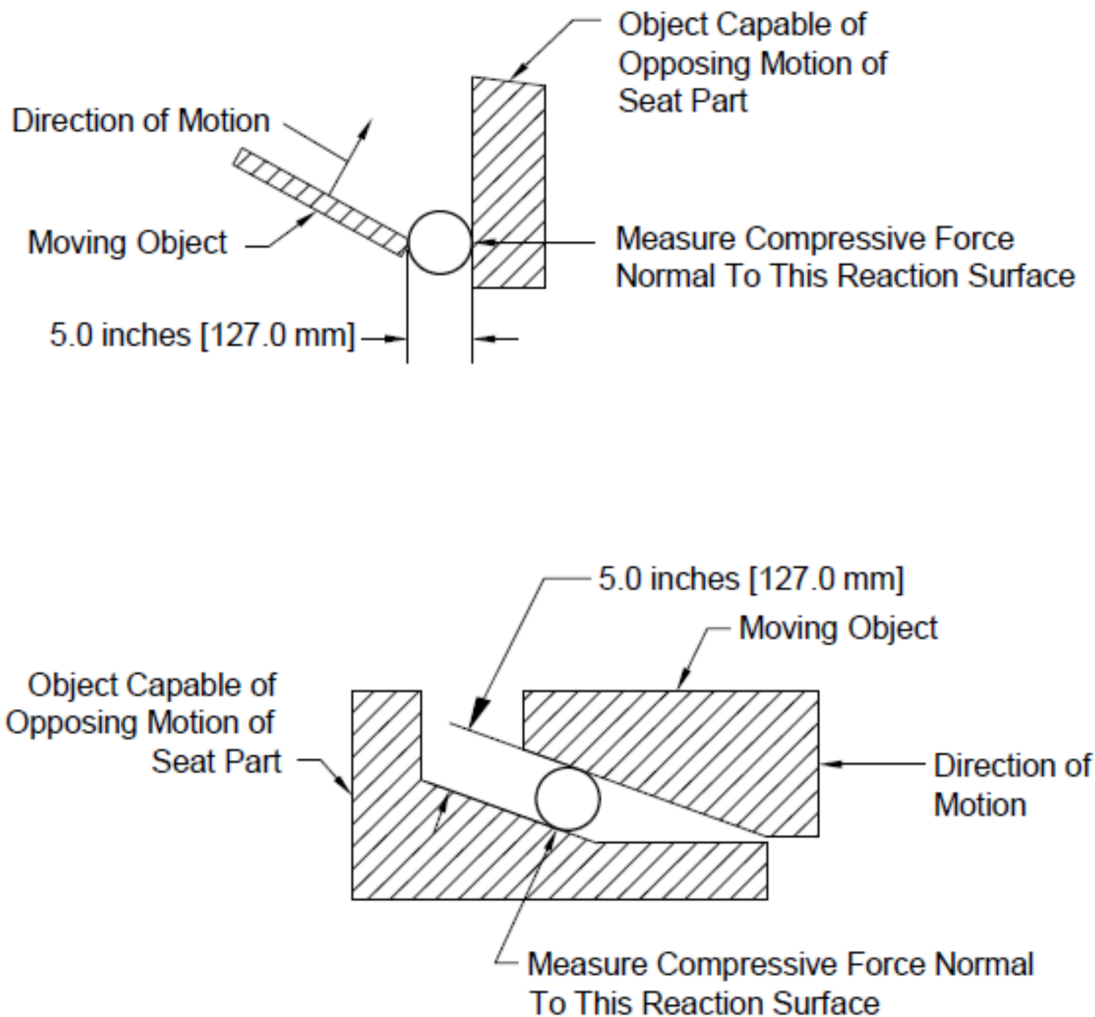

**Figure 25 - Seat back measurement points for moving parts**

Record the Following Test Information.

1. The location and body part(s) for each entrapment area identified in Section A.
2. For each potential entrapment point, take all necessary measurements according to the specific seat kinematics. This means press and hold each seat motion button, while monitoring the seat kinematics, to identify if each and every sequenced movement is safety tested and no hazardous areas exist.
3. Test method and equipment used. For consistent measurements recommend using fixed test equipment and set ups (handheld test equipment may be used).

4. Take at least three readings for each area of concern identified and evaluate the average of the readings.
- 4a. Measurements should be taken perpendicular to the reaction surface as shown in [Figure 26](#). (For example, the floor is a reaction surface.)



**Figure 26 - Force measurement example**

- 4b. Ensure that seat upholstery (representative of production) is installed before taking measurements.
5. Verify that the actuation system controller has standard production software. (Actuation system controller part number, software part number(s), software version, data table part number(s), etc., as tested.)
6. Test result data to include actual physical measurements of the forces measured and present at each potential entrapment location. (Calculations alone provide inaccurate information and are NOT recommended.)
  - \* Record if compressive or shear forces are exerted on body parts.

NOTE: For shearing hazards, also see 3.11.

- \* Load the values in a table for each mechanism evaluated and compare with [Table 4](#) for hazard level evaluations.

**Table 4 - Hazard level evaluation  
lbf (N = Newtons)**

Body Part	Hazard Levels				
	0	1	2	3	4
<b>Arm</b>	F < 60 (F < 267 N)	60 < F < 70 (267 N < F < 311 N)	70 < F < 80 (311 N < F < 356 N)	80 < F < 95 (356 N < F < 423 N)	95 < F (423 N < F)
<b>Leg</b>	F < 60 (F < 267 N)	60 < F < 70 (267 N < F < 311 N)	70 < F < 80 (311 N < F < 356 N)	80 < F < 95 (356 N < F < 423 N)	95 < F (423 N < F)
<b>Hand</b>	F < 35 (F < 156 N)	35 < F < 50 (156 N < F < 222 N)	50 < F < 75 (222 N < F < 334 N)	75 < F < 95 (334 N < F < 423 N)	95 < F (423 N < F)
<b>Foot</b>	F < 35 (F < 156 N)	35 < F < 50 (156 N < F < 222 N)	50 < F < 75 (222 N < F < 334 N)	75 < F < 95 (334 N < F < 423 N)	95 < F (423 N < F)
<b>Neck</b>	F < 35 (F < 156 N)	35 < F < 50 (156 N < F < 222 N)	50 < F < 75 (222 N < F < 334 N)	75 < F < 95 (334 N < F < 423 N)	95 < F (423 N < F)
<b>Child skull</b>	F < 35 (F < 156 N)	35 < F < 50 (156 N < F < 222 N)	50 < F < 75 (222 N < F < 334 N)	75 < F < 95 (334 N < F < 423 N)	95 < F (423 N < F)
<b>Child neck</b>	F < 22.5 (F < 100N)	22.5 < F < 35 (100 N < F < 156 N)	35 < F < 50 (156 N < F < 222 N)	50 < F < 75 (222 N < F < 334 N)	75 < F (334 N < F)

NOTE: Columns 0 and 1 are based on the human studies data referenced in the appendix. The values shown in columns 2, 3, and 4 are based on seat actuation system historical force values and are not recommended unless properly mitigated.

7. Deviations to this process.

#### Section D - Do other mitigating factors justify force values while providing protection against occupant injury?

##### Highlight the Mitigating Safety Design Features

Mitigating and aggravating factors will affect the hazard severity. Evaluate the mitigating and aggravating factors to help understand and minimize the potential pinching, shearing and passenger entrapment hazards. These factors are cumulative. You should subtract (or add) the mitigating (or aggravating) factors to determine the total hazard value.

[Table 5](#) provides examples of hazard modifying factors which if applicable, could be used to evaluate the resulting hazard value and interpret the total hazard value (see [Table 6](#)).

The interpretation of whether the exceeded area has 1, 2, or X-number of identifiable mitigating factors, then total hazard value (severity level) should be reduced by 1, 2, or X (-1, -2, - X).

If the exceeded area has 1, 2, or X-number of identifiable aggravating factors, the total hazard value (severity level) should be increased by 1, 2, or X (+1, +2, + X).

A limit of three mitigating factors is recommended for each potentially hazardous area. More than two aggravating factors is an automatic failure.

Some examples of mitigating factors are design features like:

- \* Method of control of motion

The control of the actuation system may require that the operator press a button or other control for motion to continue (press-and-hold). Alternatively, the motion may continue after the operator releases the control button (one-touch). Since

the method of stopping motion once it is started in a one-touch system may not be intuitively obvious, and quick action may be required to avert a hazard, one-touch systems have a higher hazard level (+1) than press-and-hold control button (-1).

\* Speed of closing between the parts

A slower motion speed (less than 0.5 inch (1.27 cm) per second) allows time for the operator to react to the developing hazard and time for a person to move out of the hazard area (-1).

\* Shape and stiffness of surfaces

If the shape and stiffness of the surfaces under consideration result in the force of the actuation system being applied uniformly over the largest possible area, the hazard level is decreased (-1). Conversely, hard surfaces with protruding objects will result in concentration of force in a small area and an increase in the hazard level (+1).

\* Other safety design features

- Obstruction detection with auto reverse and/or stop feature
- Audible or visual alerting system (-1)
- Sufficient padding or spacing to protect against injury or provide warning
- Location and accessibility of hazard area

Is the area easily accessed?

If No, the hazard level is decreased (-1).

Is the area where some part of a passenger is likely to be?

If No, the hazard level is decreased (-1).

Is it an area that a person other than the operator can be in?

If No, the hazard level is decreased (-1).

Is the area visible to the operator of the actuation system?

If yes, the hazard level is decreased (-1).

### Force Produced by Actuation System

The maximum force is that which is needed to stop the motion, when measured as shown in [Figure 26](#). Since different parts of the body are more vulnerable to compression forces than others, the maximum recommended force will depend on the parts of the body that could possibly be placed in that area.

The maximum force may be generated with or without the seat being occupied. A 95th percentile male occupant is recommended for the seat-occupied tests.

During normal seat operations and within these maximum values, it should be highly unlikely that the specific body parts would become injured.

When the values in [Table 3](#) are exceeded, evaluate the initial hazard level using [Table 4](#) for each entrapment area and body part affected. This practice recommends providing appropriate mitigating factors and justifications. (See [Table 5](#) for examples of mitigating factors.) The evaluation should identify the body part, mechanism (and or area), measured force value which was exceeded and why this exceeded value is acceptable and, therefore, the seat forces are compliant with this section.

### Factors Modifying Hazard Level

The initial hazard level for each compression area is zero. When the measured force exceeds the maximum force values in [Table 3](#), compare the force values with those in [Table 4](#) and identify the hazard level (0 to 4) for the mechanism(s) and body part(s).

When evaluating the effects of the modifying factors, consideration should be given to the possibility of passengers being subject to compression in the area in question.

- \* The factors increasing hazards are assigned positive numbers (+1).
- \* Factors reducing hazard are assigned negative numbers (-1).

**Table 5 - Examples of hazard modifying factor values**

Hazard Modifying Factor	Value
PCU one-touch feature/button control.	+1
PCU press-and-hold feature.	-1
Combination one touch/press-and-hold.	-1
Slow rate of approach allows time to avoid compression (less than 0.5 inches [1.27 cm] per second).	-1
Hard surfaces on moving part and opposing part.	+1
Shape and compliance of parts allows force to be distributed over contact area.	-1
Hazard area is visible.	-1
Motion can be triggered by another person other than the user of the seat.	+1
Hazard area is not easily accessible. It is not likely that a body part will be placed in the area.	-1

#### Additional Actions

After taking the sum of all appropriate hazard modifying (mitigating/aggravating) factors, the results should be compared to [Table 6](#) to determine what, if any additional actions are recommended for the installation.

- \* Each mechanism (area) and body part evaluated to this practice is to be reviewed to identify if any one reaches or exceeds the total hazard value of 2 or greater. If yes, the design is not recommended.
- \* If multiple mechanism hazards are identified each needs to be individually and properly evaluated.

**Table 6 - Hazard value and recommended actions**

Total Hazard Value	Recommended Action
0, 1	Design recommended
2 or greater	Design not recommended

NOTE: Mitigating factors do not positively prevent injury but reduce the probability of injury.

#### Specific test data detail to include in hazard determination:

- \* Identification of the areas where potentially hazardous areas exist.
- \* For each identified area:
  - Explain why any exceeded force value(s) are acceptable.
  - Justify why the protection provided will prevent occupant injury.
  - State why the mitigating factors make the electrically activated aspects of the seat safe.
- \* Prepare the seat force limit test summary information which should be used in making the determination that the seat is safe.
- \* Further analysis with justification to show that the hazard level is not significant to potentially cause injury, may be required.

NOTE: The above mitigating factors analysis procedure is a method, but not the only way to assess hazard level and system safety.

### Section E - Recommended Seat Design

No occupant injury hazards.

### Section F - Not Recommended Seat Design

Perform additional analysis as appropriate.

Perform seat redesign or modification to correct the hazard area(s).

Perform re-evaluation of this hazard determination.

#### 3.18.2.5 Rationale

All safety features, mitigating factors, measured force values and engineering justification statements should be performed per 3.18. This section was created to address the need for a more objective method for evaluating the possibility of passenger injury due to Electrically Actuated seat components. These objective criteria reduce the possibility of late seat evaluations and potential redesign.

#### 3.18.3 Further Information

Further information may be found in the following documents.

- [1] Coats, B., "Mechanics of Head Impacts in Infants," University of Pennsylvania Dissertation, 2007. <http://proquest.umi.com/pgdlink?Ver=1&Exp=01-28-2013&FMT=7&DID=1331401281&RQT=309&attempt=1&cfc=1>.
- [2] Coats, B. and Margulies, S., "Material Properties of Human Infant Skull and Suture at High Rates," J. of Neurotrauma, V23, #8, 2006. <http://www.liebertonline.com/doi/pdfplus/10.1089/neu.2006.23.1222>
- [3] International Organization for Standardization, ISO 13856-3 "Safety of Machinery - Pressure Sensitive Protective Devices - Part 3: General Principles for the Design and Testing of Pressure-Sensitive Bumpers, Plates, Wires and Similar Devices," 2006. [http://www.iso.org/iso/iso\\_catalogue/catalogue\\_tc/catalogue\\_detail.htm?csnumber=42846](http://www.iso.org/iso/iso_catalogue/catalogue_tc/catalogue_detail.htm?csnumber=42846)
- [4] Mewes, D. and Mauser, F., "Safeguarding Crushing Points by Limitation of Forces," Int. J. of Occupational Safety and Ergonomics, V9, #2, 2003. <http://www.ciop.pl/757.html>.
- [5] British Standards Institution, British Standard BS EN 12453, "Industrial, Commercial and Garage Doors and Gates - Safety in Use of Power Operated Doors - Requirements," 2000. <http://www.bsi-global.com/en/Search-Results/?q=12453>.
- [6] Underwriters Laboratories, Inc., UL 325 - "UL Standard for Safety for Door, Drapery, Gate, Louver, and Window Operators and Systems," 2002. [http://www.comm-2000.com/productdetails.aspx?sendingPageType=BigBrowser&CatalogID=Standards&ProductID=UL325\\_5\\_S\\_20020607\(ULStandards2\)](http://www.comm-2000.com/productdetails.aspx?sendingPageType=BigBrowser&CatalogID=Standards&ProductID=UL325_5_S_20020607(ULStandards2))
- [7] U.S. Code of Federal Regulations - 16 CFR 1211.13 - Consumer Product Safety Commission Safety Standard for Automatic Residential Garage Door Operators.
- [8] U.S. Code of Federal Regulations - 49 CFR 571.118 - Department of Transportation MVSS 118: Power - Operated Window, Partition, and Roof Panel Systems.

### 3.19 Crew Size

#### 3.19.1 Applicable Policy and Regulations

##### 14 CFR Part 25.771 Amendment 25-4

Pilot compartment.

- (a) Each pilot compartment and its equipment must allow the minimum flight crew (established under Sec. 25.1523) to perform their duties without unreasonable concentration or fatigue.
- (b) The primary controls listed in Sec. 25.779(a), excluding cables and control rods, must be located with respect to the propeller so that no member of the minimum flight crew (established under Sec. 25.1523), or part of the controls, lies in the region between the plane of rotation of any inboard propeller and the surface generated by a line passing through the center of the propeller hub making an angle of 5 degrees forward or aft of the plane of rotation of the propeller.
- (c) If provision is made for a second pilot, the airplane must be controllable with equal safety from either pilot seat.

##### 14 CFR Part 25.777 Amendment 25-46

- (a) Each cockpit control must be located to provide convenient operation and to prevent confusion and inadvertent operation.
- (b) The direction of movement of cockpit controls must meet the requirements of Sec. 25.779. Wherever practicable, the sense of motion involved in the operation of other controls must correspond to the sense of the effect of the operation upon the airplane or upon the part operated. Controls of a variable nature using a rotary motion must move clockwise from the off position, through an increasing range, to the full on position.
- (c) The controls must be located and arranged, with respect to the pilots' seats, so that there is full and unrestricted movement of each control without interference from the cockpit structure or the clothing of the minimum flight crew (established under Sec. 25.1523) when any member of this flight crew, from 5 feet 2 inches (157 cm) to 6 feet 3 inches (191 cm) in height, is seated with the seat belt and shoulder harness (if provided) fastened.

##### AC 25-785-1B (14 CFR Part 25.785) Guidance 6. c. (3)

### 3.20 Occupant Height

General anthropometric data indicates that adult occupant sitting height to the mid-shoulder can range from about 20 inches (50.8 cm) for a small female (2.5 percentile) to 25 inches (63.5 cm) for a large male (97.5 percentile). A mid-shoulder height of 23.3 inches (59.2 cm) approximates a large female and an average male. Locating the shoulder strap attach point at this height, allowing for seat cushion compression, would accommodate both the large and small occupant, and allow the trailing length of upper torso restraint straps to remain close to the +30, -5-degree guidelines. It should be noted that it may be impossible to accommodate extremely large and extremely small people in a given seat location. Installation of upper torso restraint may require certain tradeoffs to assure the best installation, given the limitations of the space available.

#### 3.20.1 Recommended Practice

Flight crew seats (cockpit) and restraints should accommodate adult occupants ranging in stature (standing height) from 5 feet 2 inches (157 cm) to 6 feet 3 inches (191 cm).

Flight attendant seats and restraints should accommodate adult occupants ranging in stature (standing height) from fifth percentile female to 95th percentile male according to [Table 7](#). Additional anthropometric measurements can be obtained from the CAESAR study (see 2.1) if required.



**Table 7 - CAESAR anthropometric database sitting and standing height**

	CAESAR
Sitting 5% Female	31.86 inches (80.9 cm)
Sitting 95% Male	38.78 inches (98.5 cm)
Standing 5% Female	60.08 inches (152.6 cm)
Standing 95% Male	74.83 inches (190.1 cm)

Crew restraint systems, while fastened, should neither significantly impede access to controls nor prevent crews from performing their duties.

### 3.21 Occupant Size

#### 3.21.1 Applicable Policy and Regulations

##### 14 CFR Part 25.785 Amendment 25-88

- (a) A seat (or berth for a non-ambulant person) must be provided for each occupant who has reached his or her second birthday.
- (b) Each seat, berth, safety belt, harness, and adjacent part of the airplane at each station designated as occupiable during takeoff and landing must be designed so that a person making proper use of these facilities will not suffer serious injury in an emergency landing as a result of the inertia forces specified in Sections 25.561 and 25.562.

#### 3.21.2 Recommended Practice

Passenger seats and restraints should accommodate occupant sizes encompassing the 2-year-old child to the 99th-percentile male occupant. The restraint length should be adjustable to function properly in safely retaining this range of occupants.

### 3.22 Attendant Step

#### 3.22.1 Applicable Policy and Regulations

##### 14 CFR 25.1411 Amendment 25-0

- (a) Accessibility. Required safety equipment to be used by the crew in an emergency, such as automatic life raft releases, must be readily accessible.

#### 3.22.2 Recommended Practice

If a dedicated attendant step is part of the seat design and is required for installation, it should support loading per 3.26. The step should be able to accommodate a foot size of 4 inches (10.2 cm) wide, minimum of 3 inches (7.6 cm) high, and support the ball of the foot as shown in [Figure 27](#), which would typically permit the foot to be inserted a minimum of 3.5 inches (8.9 cm).

Care should be taken to ensure the height of the step is suitable for use by a 5th percentile female.



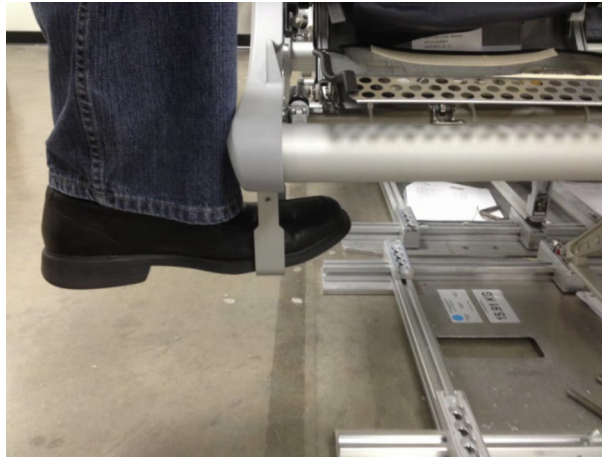

**Figure 27 - Acceptable foot insertion into stirrup-type step**



**Figure 28 - Typical economy class step**



**Figure 29 - Typical first/business class step**

### 3.23 Wear and Deterioration

#### 3.23.1 Applicable Policy and Regulations

Design guidance.

#### 3.23.2 Recommended Practice

The seating system should be designed so that the primary structural elements and other safety related items can be readily inspected during scheduled maintenance to detect wear, deterioration, or any other condition that would degrade safety.

All members of the primary structure should be protected to minimize deterioration from environmental factors. Members should be protected or designed to accommodate deterioration without compromise of safety or function. The design should address loss of strength caused by vibration, humidity, dissimilar metals, in-service impact damage, and other expected conditions, including spillage, exposure to cleaning agents, or dirt.

### 3.24 Fire Protection Requirements

#### 3.24.1 Applicable Policy and Regulations

##### 14 CFR 25.853 - Amendment 25-83

For each compartment occupied by the crew or passengers, the following apply:

- (a) Materials (including finishes or decorative surfaces applied to the materials) must meet the applicable test criteria prescribed in Part I of Appendix F of this part, or other approved equivalent methods, regardless of the passenger capacity of the airplane.
- (c) In addition to meeting the requirements of paragraph (a) of this section, seat cushions, except those on flight crewmember seats, must meet the test requirements of Part II of Appendix F of this part, or other equivalent methods, regardless of the passenger capacity of the airplane.

#### 3.24.2 Recommended Practice

1. All materials used in the seat shall have fire properties as specified in the applicable Federal Regulations.
2. Small parts used in seats do not need to meet the test requirements according to 14 CFR 25.853(a) Part I Appendix F when their use does not contribute significantly to the propagation of fire.

##### 3.24.2.1 Definition of Small Part

A small part may not have a volume greater than 8 in<sup>3</sup> (131 cm<sup>3</sup>) and the largest single (one side) projected surface may not exceed 9 in<sup>2</sup> (58 cm<sup>2</sup>). For example, the projected surface area of a cylinder is its diameter multiplied its length. Manipulation of the part to force it within these limits is not permitted.

[Table 8](#) is a list of items that have been established as small parts (size and volume limits still apply).

**Table 8 - Typical small parts**

Part	Comment
Knobs	
Handles	
Rollers	
Fasteners, nuts, washers	
Clips	
Grommets	
Rub strips	
Pulleys	

Small electrical parts	Capacitors, resistors, etc.
Placards	
Tie wraps	
Cable ties	Including cable tie mounts
Bushings	
Spacers	
Hooks	
Switches	
Electrical tape	Wrapped in a small area
Thread	

NOTE: This small part definition does not apply to parts that must meet Federal Regulations regarding the self-extinguishing properties of insulation on electrical wire and electrical cable (e.g., 14 CFR 25.869, amendment 25-113).

### 3.24.2.2 Attachment of Small Parts

A small part may be bonded, or mechanically attached, to a larger part without losing its designation as a small part. FAA Policy Memo PS-ANM-25.853-01-R2 provides more details on acceptable methods of compliance.

### 3.24.2.3 Tiling

The tiling effect of multiple small parts installed within close proximity of each other is a concern because the combined ability of the small parts to contribute to the propagation of fire is unknown. Currently, review of multiple small parts installed in close proximity is performed subjectively. Until further data is available, the definition of suitable criteria is outside of the scope of this section.

## 3.25 Anti-Rattle Device

### 3.25.1 Applicable Policy and Regulations

#### 14 CFR Part 25.601

General.

The airplane may not have design features or details that experience has shown to be hazardous or unreliable. The suitability of each questionable design detail and part must be established by tests.

### 3.25.2 Recommended Practice

On passenger seats that use studs or other fittings for attachment of the seat to seat tracks or fittings, anti-rattle designs or devices should be considered to reduce wear on the seat tracks or fittings.

## 3.26 Recline Egress

### 3.26.1 Applicable Policy and Regulations

#### 14 CFR Part 25.601

General.

The airplane may not have design features or details that experience has shown to be hazardous or unreliable. The suitability of each questionable design detail and part must be established by tests.

### 3.26.2 Recommended Practice

Where seat recline encroaches on a flight attendant assist space, passenger seat recline and control mechanisms should have an override feature so that the reclined seat back may be moved to the upright position without activating the recline control and by exerting a force not greater than 35 pounds (156 N) near the top of the seat back.

### 3.27 Abuse Loads for Secondary Structures

#### 3.27.1 Applicable Policy and Regulations

##### 14 CFR Part 25.601

##### General.

The airplane may not have design features or details that experience has shown to be hazardous or unreliable. The suitability of each questionable design detail and part must be established by tests.

#### 3.27.2 Recommended Practice

Passenger seat secondary structure listed in [Table 9](#) should be designed to meet the abuse load defined.

**Table 9 - Seat secondary structure abuse loads**

Aisle Armrests	300 pounds (1334 N )	Applied downward 3 inches (7.6 cm) from the forward end of armrest.
Aisle Armrests	200 pounds (890 N)	Applied sideways 3 inches (7.6 cm) from the forward end of armrest.
Aisle Armrest (rotating)	75 pounds (334N) – aft 50 pounds (222N) – Left and Right	Armrest in fully rotated position. Load applied to the armrest 3 inches (7.6 cm) aft from the forward end of armrest
Other Armrests	250 pounds (1112 N)	Applied downward 3 inches (7.6 cm) from the forward end of armrest.
Other Armrests	150 pounds (667 N)	Applied sideways 3 inches (7.6 cm) from the forward end of armrest.
Food Tray Tables	150 pounds (667 N)	Applied downward and evenly distributed.
Flight Attendant Step	300 pounds (1334 N )	Applied downward and evenly distributed.
Seat Back	200 pounds (890 N)	Applied to the top of the seat back opposite the seat lock in a direction to cause back to recline.

Values for Legrest and Footrest/footbar are not currently defined.

##### NOTES:

1. Abuse loads are considered ultimate loads. No equivalent limit load case exists.
2. Seat secondary structure should not be damaged or deformed under the loads in [Table 9](#) to the extent that continued occupation or operation of the seat is prevented.
3. In the event that a secondary structure breaks or deforms, no projections, protrusions, or sharp edges may exist. Breakage of the attendant step or seat back is not permitted.

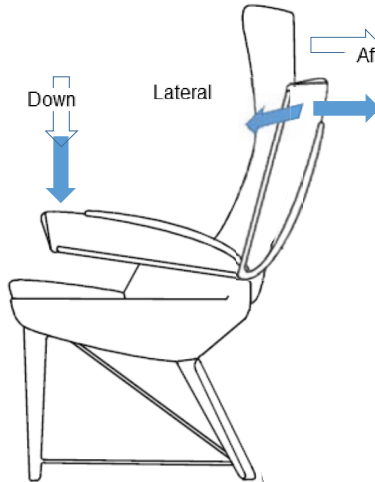

**Figure 30 - Load directions for rotating aisle armrest**

### 3.28 Fatigue Life Criteria

#### 3.28.1 Applicable Policy and Regulations

Design guidance.

#### 3.28.2 Recommended Practice

Passenger seat secondary structure should be designed to reasonable fatigue life criteria. The following are guidelines, where applicable:

**Table 10 - Seat secondary structure fatigue life**

20000 cycles	80 pounds (356 N)	On corner of back opposite to lock in a direction to cause back to recline for a full break over back and in both fore and aft directions for backs with limited or no break over.
10000 cycles	50 pounds (222 N)	On end of aisle and center armrests in inboard and outboard directions.
20000 cycles	75 pounds (334 N)	On end of center armrests in a downward direction.
20000 cycles	100 pounds (445 N)	On end of aisle armrests in upward and downward directions.
50000 cycles	170 pounds (756 N)	Evenly distributed over seat bottom cushion on the seat frame in a downward direction.
15000 cycles		Seat back recline mechanism and linkages.
1000 cycles		Seat back break over system to remain 20 to 35 pounds (89 to 156 N) without adjustment.
10000 cycles	50 pounds (222 N)	Equally distributed load on food tables in a downward direction.

### 3.29 Legrest and Footrest/Footbar Definition

#### 3.29.1 Applicable Policy and Regulations

##### 14 CFR Part 25.601

General.

The airplane may not have design features or details that experience has shown to be hazardous or unreliable. The suitability of each questionable design detail and part must be established by tests.

### 3.29.2 Recommended Practice

**Legrest:** A legrest is a device mounted on the seat that supports the seated occupant's legs. The legrest is operated by the occupant to deploy and to stow.

**Footrest/Footbar:** A footrest/footbar is a device mounted to the legrest that is used to support a seated occupant's feet. The footrest/footbar is operated by the occupant to deploy and to stow.

**Aft Mounted Footrest/Footbar:** A footrest/footbar mounted to the seat structure to be used by the occupant in the seat behind.

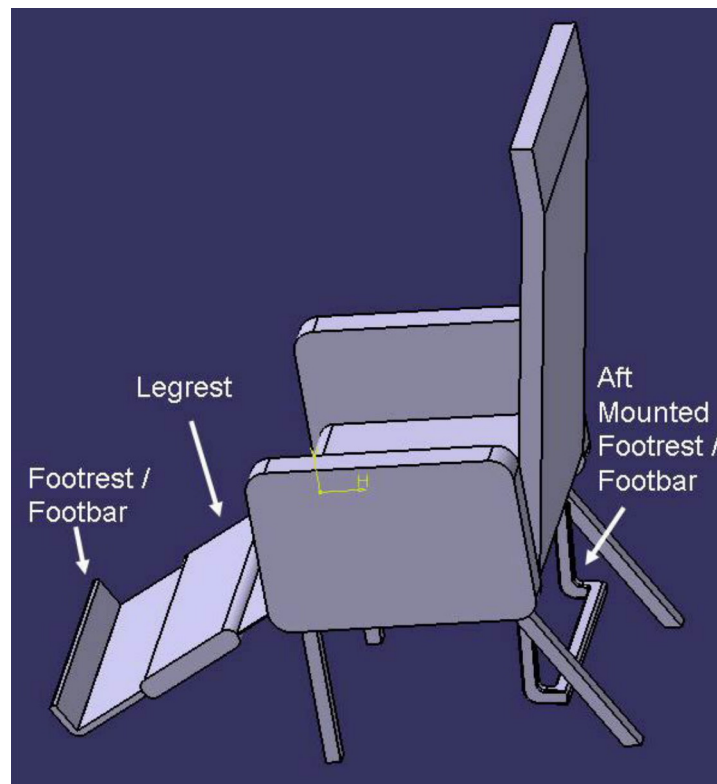

**Figure 31 - Seat description**

As a design goal, legrests and footrests/footbars should not deploy under any normal flight or emergency landing load. This helps maintain the required minimum aisle width(s) for a given configuration and eliminates subjective evaluations for egress hazards.

If the legrest deploys, then the following conditions should be met:

1. During the act of standing up and exiting the seat the legrest returns (with normal passenger movement) and remains in its stowed position.

NOTE 1: This evaluation needs to consider the case of the seat being unoccupied with an occupant from an adjacent seat passing in front of the unoccupied seat.

NOTE 2: Normal passenger movement is the act of the seated occupant getting up out of the seat and moving to egress the airplane (i.e., unbuckling their restraint, standing, turning towards the aisle, and moving into the aisle). It does not include additional movements to lift or stow items, or latching an item in place.

2. The legrest should not deploy into an exit aisle.

3. The deployment is measured and documented during testing.

For footrest/footbar:

It may be acceptable for a footrest/footbar to deploy during a test when the conditions a through d have been met:

a. The footrest/footbar lays flat against the floor.

NOTE: Footrest/footbar designs of more than 1 inch (2.5 cm) in thickness may need to be re-evaluated for a tripping hazard.

b. The footrest/footbar will not trap an occupant's foot.

NOTE: This evaluation needs to consider other passengers using this area for egress.

c. The footrest/footbar does not deploy into an exit aisle.

d. The deployment is measured, documented and considered when evaluating egress if the item deploys into an area that must be used by multiple passengers (in addition to the occupant of the seat) for egress.

#### For Aft mounted Footrest/Footbar:

It may be acceptable for a footrest/footbar to deploy during a test when the following condition has been met:

The fully or partially deployed footrest/footbar does not impinge into the egress path of the occupants unless normal passenger movement stows the footrest/footbar.

### 3.30 Object Entrapment

Small objects (i.e., cell phones, PC tablets, computers, wallets, chargers, cords, keys, etc.) shall not be able to migrate to a location in the seat where the object may prevent the return of critical features to a TTL position, or create a potential fire hazard due to being crushed.

Seats should be designed so that small objects are easily retrievable if they migrate into the seat structure. This may be done by prevention (seals, brushes, or shrouds), or the object can fall into an accessible area for retrieval. For any area that allows items to fall to the floor under or around a seat, there must be adequate access (removal of panels by crew member, by extending features such as a legrest, etc.) to allow the crew member to retrieve them.

### 3.31 Life Vest Stowage Ease of Search

#### 3.31.1 Application Policy and Regulations

##### 14 CFR Part 25.795(c)(3)(iii)

#### Security Considerations

(c) An airplane with a maximum certificated passenger seating capacity of more than 60 persons or a maximum certificated takeoff gross weight of over 100000 pounds (45359 kg) must comply with the following:

(3) Interior design to facilitate searches. Design features must be incorporated that will deter concealment or promote discovery of weapons, explosives, or other objects from a simple inspection in the following areas of the airplane cabin:

(iii) Life preservers or their storage locations must be designed so that tampering is evident.

#### FAA Advisory Circular 25.795-8, "Interior Design to Facilitate Searches"

### 3.31.2 Recommended Practice

The following design recommendations for the life vest storage locations on passenger seats and surrounding furniture are to facilitate airplane cabin searches by trained security personnel.

Common methods to indicate tampering of the life vest container such as seals, locks, or straps have the device as the indicator. However, it is also possible the device may be located separate from the tamper indication. Therefore, the design recommendations listed will denote whether it is applicable to the device itself (tamper-evident device), or its indication of tampering. More than one tamper-evident device may be used; however, each installed tamper-evident device shall meet the recommended practices.

The tamper indication for each life vest container shall take into account the indicator's location within the airplane cabin (not just the seat). Seat pitch, distance from an aisle, and surrounding cabin structure may influence the ability of the inspector to view the indication. For example, for an indicator mounted to the life vest container, a small seat pitch may cause the forward seat to block the view to the seat directly aft. Outboard seats are typically the most critical due to the distance from the main aisle.

Radio frequency identification (RFID) technology may be applied to indicate tampering; however, this capability shall be considered a supplement to the design recommendations described in this section. AS5678 provides standards for the use of passive RFID tags on aircraft.

While a life vest container design may allow viewing of the container interior volume (typically by using transparent materials), this functionality shall not be considered when applying the design recommendations described in this section.

#### 3.31.2.1 Tamper-Evident Device

- a. Installation, maintenance, and consistency should be considered during the design of the tamper-evident device.
- b. Removing and reinstalling the tamper-evident device shall result in the device being activated or noticeably damaged. For example, the partial removal of an adhered seal will cause the tamper indication to appear.
- c. After the tamper-evident device has been activated, the passenger shall not be able to easily reset or manipulate the device to appear as though the container has not been accessed. For example, a torn tamper-evident seal shall not be able to be reapplied to appear intact. If the tamper-evident device includes a resettable function, the reset feature shall be designed such that only authorized airline personnel will be able to reset the feature. If the tamper-evident device uses the breaking of ties or cords to indicate access, the remaining length does not allow rethreading, resetting, or hiding the break. One method of simplifying the assessment of seals, ties, or cords is to have a single designed break location instead of having multiple break locations.

#### 3.31.2.2 Tamper-Evident Device Installation

- a. The tamper-evident device should be protected from inadvertent contact with the seated occupant, cleaning devices or personnel, etc. Recessing the tamper-evident device is one method of accomplishing this.
- b. When the tamper-evident device is installed, the visual indication of lifevest storage location tampering shall activate when the rigid shape defined in [Figure 32s](#) inserted into the storage location. This evaluation is performed by a seated, unbuckled person moderately pulling on the door or flap with one hand, while the other hand attempts to insert the shape described below through any gap between the container and the container's door or flap. No tools or common objects are used in attempting to create a gap between the door or flap and the container. Corners and sides of the container door or flap are areas of emphasis. Evaluation shall consider the seat and container in any design configuration (e.g., reclined, Legrest extended, table deployed, etc).



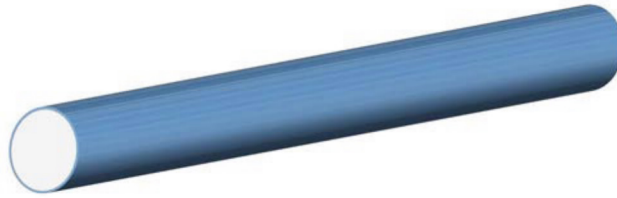

Rod: 0.35 inch (0.9 cm) diameter, 3.9 inch (9.9 cm) long

**Figure 32 - Evaluation object shape**

- a. If a tool is used to install or maintain the tamper-evident device, space should be reserved for tool access.
- b. If the tamper indication uses a change in color, the color(s) used to indicate tampering shall have sufficient contrast with the surrounding surface. If using text, lines, or symbols, the indication shall contrast with the background.
- c. The installed tamper-evident device(s) shall not hinder retrieval of the life vest (see 3.3).
- d. Retention of the life vest under all applicable loading conditions shall not rely on the tamper-evident device(s) being installed. Demonstration of retention without the tamper-evident device is the conservative case.

### 3.31.2.3 Lifevest Storage Location

The lifevest storage location are those volumes in and around the lifevest container that are concealed by a lifevest container access covering (e.g., door or flap). This includes the following:

- \* The container volume where the lifevest is stowed.
- \* Volumes behind container doors, panels, flaps. This includes voids created when surfaces overlap each other to close the container opening. For example, pouch style container designs may use overlapping flaps to close the container opening, but due to this overlapping may form pockets between the flaps that can be accessed (Figure 33). When the lifevest container door or flap is a larger area than the container opening, the volumes exposed when the door or flap is open is included in the evaluation (Figure 34).

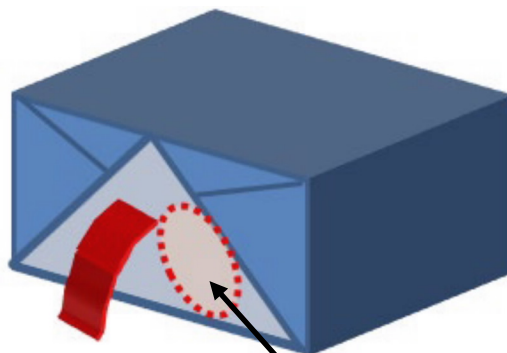

Void formed between two flaps

**Figure 33 - Example of overlap**

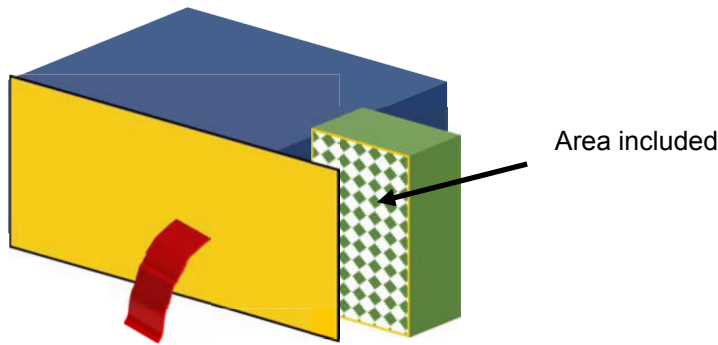

**Figure 34 - Example of door larger than container opening**

### 3.31.2.4 Lifevest Containers

It is recommended the container inner surfaces do not have gaps or holes larger than a 0.35 inch (0.9 cm) diameter circle (see Figure 35).

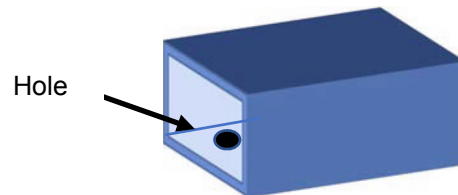

**Fig Example of hole in inner container surface**

### 3.31.2.5 Inspection Method (Performed by the Installer)

Visibility of the tamper indication shall be assessed using the following criteria:

- Seat and associated seat furniture shall be in the takeoff and landing position.
- Ambient cabin lighting may be used during the inspection.
- Personnel ranging in size from a 5% female to a 95% male shall be able to see the tamper indication
- Inspection shall be accomplished by standing in the aisle in an upright position, bending over the seats, and/or stepping into the seat row. Leaning on a seat component (e.g., console, seat pan, ottoman, and/or seatback) is acceptable for support only. Placement of hands, knees, arms, legs, torso, or back on the aircraft floor shall not be required in order to view the tamper indication.

## 3.32 Manual Override for TTL Position of Electrically Operated Seats

### 3.32.1 Applicable Policy and Regulations

#### 14 CFR Part 25.601

#### General.

The airplane may not have design features or details that experience has shown to be hazardous or unreliable. The suitability of each questionable design detail and part must be established by tests.

### 14 CFR Part 25.785 Amendment 25-88

- (b) Each seat, berth, safety belt, harness, and adjacent part of the airplane at each station designated as occupiable during takeoff and landing must be designed so that a person making proper use of these facilities will not suffer serious injury in an emergency landing as a result of the inertia forces specified in Sections 25.561 and 25.562.

The intent of the manual override is to operate the seat in the event of a failure of the electrical actuation system. The manual override is intended for use when the passenger seat is unoccupied.

#### 3.32.2 Recommended Practice

- \* The manual override could be used without a passenger sitting in the affected passenger seat.
- \* The manual override is intended to be operated by cabin crew. Operating instructions for override use must be provided by means of a placard near the override controls or by documentation provided to the crew.
- \* The way to use the manual override should be simple and each lever or button shall be marked.
- \* The forces and handling should be such that a single cabin crew (5th-percentile female to 95th-percentile male) should be able to bring the seat into the TTL position.
- \* In case of failure of the electrical TTL indication (e.g., after loss of electrical power), the manually operated passenger seat design should provide a distinct, visual, audible, or tactile indicator to identify whether the seat is in a position certified for TTL.
- \* The operation of the manual backup should not lead to a hazard.
- \* The seat manufacturer should provide the relevant operating instructions for the handling of the manual override.

#### 3.33 Environmentally Preferable Material

##### 3.33.1 Applicable Policy and Regulations

Not applicable.

##### 3.33.2 Recommended Practice

Environmentally preferable materials should be used to the maximum extent possible when designing and manufacturing seats.

The U.S. Environmental Protection Agency (EPA) maintains a list of undesirable materials on their website, which, at the time of writing, is located at [www.epa.gov/wastes/hazard/wastemin/priority.htm](http://www.epa.gov/wastes/hazard/wastemin/priority.htm).

The European Union maintains a similar list on their website, which, at the time of writing, is located at <http://echa.europa.eu/web/guest/candidate-list-table>.

Materials on these lists should be minimized, or avoided, unless needed to meet the requirements of the applicable TSO, or installation requirements.

#### 4. NOTES

##### 4.1 Revision Indicator

A change bar (|) located in the left margin is for the convenience of the user in locating areas where technical revisions, not editorial changes, have been made to the previous issue of this document. An (R) symbol to the left of the document title indicates a complete revision of the document, including technical revisions. Change bars and (R) are not used in original publications, nor in documents that contain editorial changes only.

PREPARED BY SAE AIRCRAFT SEAT COMMITTEE